



**Battery Park
City Authority**

REQUEST FOR PROPOSALS

FOR

Battery Park City Ballfield & Community Center Resiliency Project:

General Contractor Services

Table of Contents

I. SUMMARY..... 1

II. GENERAL PROVISIONS 1

III. TIMETABLE & DESIGNATED CONTACT 2

 A. Key Dates 2

 B. Anticipated Contract Term..... 2

IV. GENERAL REQUIREMENTS..... 3

 A. Minimum Qualification Requirements..... 3

 B. MBE/WBE/SDVOB Participation, Joint Ventures, and Sub-contracting Goals 3

 C. Restricted Period 3

 D. Submission of Proposals 3

V. PROPOSAL FORMAT AND CONTENTS..... 4

 A. Proposal Format 4

 B. Proposal Content 4

VI. INFORMATION REQUIRED 5

 A. Questions and Information Sought Relating to the Work 5

 B. Questions and Information Sought Relating to Proposer’s Firm & Eligibility 6

 C. Required Attachments 6

VII. INSURANCE AND BONDS REQUIREMENTS 8

 A. General Requirements 8

 B. Insurance Requirements for the Selected Proposer 8

 C. Insurance Requirements for all Sub-contractors 9

 D. Payment and Performance Bonds 9

VIII. COST PROPOSAL: FORMAT AND REQUIRED INCLUSIONS 10

IX. SELECTION PROCESS 10

 A. Evaluation 10

 B. Interviews 10

 C. Evaluation Criteria for Selection..... 11

 D. Basis for Contract Award..... 11

X. NON-COLLUSION..... 11

XI. IRAN DIVESTMENT ACT 11

XII. ENCOURAGING USE OF NEW YORK STATE BUSINESSES IN CONTRACT PERFORMANCE.. 12

EXHIBIT A – SCOPE OF WORK

EXHIBIT B – MBE/WBE/SDVOB REQUIREMENTS, MBE/WBE AND EEO POLICY STATEMENT & DIVERSITY PRACTICES QUESTIONNAIRE

EXHIBIT C – BPCA’S STANDARD FORM OF CONTRACT

EXHIBIT D – FORM OF COST PROPOSAL

EXHIBIT E – FORM OF BID BREAKDOWN

EXHIBIT F – FORM OF LABOR RATES

EXHIBIT G – FORM OF UNIT PRICING

EXHIBIT H – DRAWINGS & SPECIFICATIONS

EXHIBIT I – ACKNOWLEDGEMENT OF ADDENDA

EXHIBIT J – LIST OF BPCA & BPCPC BOARD MEMBERS AND EMPLOYEES

I. SUMMARY

Battery Park City Authority d/b/a Hugh L. Carey Battery Park City Authority (“BPCA”) requests proposals (individually a “Proposal” and collectively the “Proposals”) from general construction contractors or metal contractors (individually a “Proposer” and collectively the “Proposers”) to provide BPCA with general contractor services for the Battery Park City Ballfield and Community Center Resiliency Project (the “Project”).

The Project will consist of general contractor services related to the construction, fabrication, and installation of an interim flood barrier (the “Ballfield Barrier System”) along the northern, eastern, and southern boundaries of the Battery Park City Ballfields (the “Ballfields” or the Project Site”), located immediately west of West Street and between Warren Street and Murray Street. The Ballfield Barrier System will have an intended useful life of up to ten (10) years and is expected to remain in place until the completion of the North Battery Park City and South Battery Park City Resiliency Projects, at which time the Ballfield Barrier System will be rendered redundant based upon current 2050’s one hundred-year storm projections.

The Ballfield Barrier System will consist primarily of eight hundred (800) linear feet of metal panels, with decorative metal overlays, installed within a new concrete grade beam and attached to the Ballfield’s existing perimeter fencing. Associated drainage and landscaping work is also required. A detailed Scope of Work for which the selected Proposer will be responsible is attached as Exhibit A (the “Services” or the “Work”).

The drawings and specifications are currently at ninety-five percent (95%) completion. The ninety-five percent (95%) design documents are attached to this RFP as Exhibit H. One-hundred percent (100%) design documents will be issued by an addendum to this Request for Proposals in mid-November, in advance of the Proposal due date and, when issued, shall fully replace and supersede the ninety-five percent (95%) design documents. All references to the “Construction Documents” throughout the RFP, and all obligations related thereto, refer to those prospective one-hundred percent (100%) design documents (the drawings and specifications associated with this request for Proposals).

Created in 1968, BPCA is a New York State public benefit corporation responsible for financing, developing, constructing, maintaining, and operating Battery Park City as a richly diversified, mixed-use community providing residential and commercial space, with related amenities such as parks, plazas, recreational areas, and a waterfront esplanade. A summary of BPCA’s structure, mission, and history, as well as the Battery Park City project area, may be viewed at: www.bpca.ny.gov. Public information regarding BPCA’s finances, budget, internal controls, guidelines, and policies may be viewed at: www.bpca.ny.gov/public-information. Information relating to the Battery Park City Parks Conservancy Corporation (“BPCPC”), BPCA’s affiliate, may be viewed at: www.bpcparks.org.

New York State-certified Minority-Owned Business Enterprises (“MBE”), Women-Owned Business Enterprises (“WBE”), and Service-Disabled Veteran-Owned Businesses (“SDVOB”) are encouraged to submit Proposals.

II. GENERAL PROVISIONS

This request for Proposals, including attachments, exhibits, and any amendments or addenda (collectively, the “RFP”) is subject to the rights reserved by BPCA, including, but not limited to BPCA’s right to:

- Withdraw and/or cancel this RFP at any time before final award of the contract;
- request clarification and/or additional information from any or all Proposers;
- amend any term or requirement of this RFP at any time before award of a contract (Proposers may amend their Proposals, as directed by BPCA, if BPCA materially alters or amends the RFP after submission of Proposals);

- alter any key dates or deadlines related to this RFP;
- award the Work, in whole or in part, to one or more Proposers with or without interviews;
- reject any Proposal that does not strictly conform to the requirements of this RFP;
- conduct an interview with any or all of the Proposers to aid the evaluation process; and,
- negotiate potential contract terms with any Proposer.

BPCA is not liable or responsible in any way for any expenses incurred in the preparation of a Proposal in response to this RFP. All information submitted in response to this RFP is subject to the Freedom of Information Law, Article 6 of the New York State Public Officers Law (“FOIL”), which requires public access to certain documents possessed by BPCA, unless a specific exemption applies. Proposers are responsible for identifying any information in their respective Proposals considered to be confidential and exempt from FOIL. BPCA, however, is obligated to disclose information consistent with the requirements of FOIL, New York State Public Authorities Law Section 87.

III. TIMETABLE & DESIGNATED CONTACT

A. *Key Dates*

Subject to change at BPCA’s discretion, the following are key dates for this RFP:

- RFP issued: November 6, 2019
- Pre-proposal meeting and subsequent site visit (attendance is highly recommended):
 - Date: November 12, 2019 at 9:30 AM
 - Location: BPCA Offices – 200 Liberty St., 24th floor | New York, NY
- Deadline to submit questions to BPCA: November 15, 2019 (by email only)

All questions regarding this RFP should be submitted in writing via email to **Michael LaMancusa**, BPCA’s Assistant Contracting Officer, at michael.lamancusa@bpca.ny.gov (the “Designated Contact”).

- BPCA’s response to substantive questions: November 21, 2019 (via posting on the BPCA website)
- **PROPOSAL DUE DATE**: December 4, 2019 at 3:00 PM (the “Due Date”)
- **INTERVIEWS (IF DEEMED NECESSARY BY BPCA) WILL BE HELD ON December 10 and/or 11.**
- Anticipated Contract start date: February 2020

B. *Anticipated Contract Term*

The anticipated term of the contract awarded pursuant to this RFP (the “Contract”) will be thirteen (13) months; however, it is expected that construction will be substantially complete, sufficient to render the Ballfield Barrier System fully effective, no later than July 31, 2020. BPCA reserves the right to terminate the Contract at any time, with or without cause, in accordance with the terms of the Contract. BPCA’s sample form of contract (the “Standard Form of Contract”) is attached as Exhibit C.

IV. GENERAL REQUIREMENTS

A. Minimum Qualification Requirements

The following are the minimum qualification requirements for this RFP. Proposals that fail to meet these requirements will be rejected.

- 1) The Proposer must have an office in New York State (a New York City office is preferred);
- 2) The Proposer must be lawfully authorized to do business in the State of New York; and,
- 3) The Proposer must have at least five (5) years of experience providing general contracting services for major urban projects, at least two (2) of which have been performed in New York City.

B. MBE/WBE/SDVOB Participation, Joint Ventures, and Sub-contracting Goals

Contractor requirements and procedures for business participation opportunities for New York State certified MBEs/WBEs/SDVOBs and equal employment opportunity requirements relating to minority group members and women are attached as Exhibit B. For questions relating to MBE/WBE/SDVOB participation, joint ventures and sub-contracting goals *only*, please contact the “MBE/WBE/SDVOB Designated Contact” Mr. Justin McLaughlin-Williams at justin.mclaughlin-williams@bpca.ny.gov or 212-417-2337 (the “MBE/WBE/SDVOB Designated Contact”).

C. Restricted Period

New York State’s State Finance Law sections 139-j and 139-k apply to this RFP, restricting Proposers’ contacts with BPCA. Proposers are restricted from making any contact (defined as oral, written or electronic communications with BPCA under circumstances where a reasonable person would infer that a communication was intended to influence BPCA’s conduct or decision with respect to a procurement) relating to this RFP with anyone other than the Designated Contact, as specified in Section III.A., or MBE/WBE/SDVOB Designated Contact, as specified in Section IV.B., from the time of Proposer’s receipt of notice of this RFP through the date of the Final Award as defined in BPCA’s Procurement Guidelines (the “Restricted Period”). BPCA employees must record certain contacts during the Restricted Period, including, but not limited to, any oral or written communications that could reasonably be seen as intended to influence BPCA’s conduct or award of this RFP. Upon notice of an improper contact, BPCA must make a determination regarding the Proposer’s eligibility to continue participating in this RFP.

D. Submission of Proposals

Proposals must be received by BPCA no later than 3:00 PM on December 4, 2019.

Each Proposer must submit six (6) paper copies and a PDF version (via CD-ROM or flash drive) in a sealed package clearly marked “Proposal Enclosed – Ballfield & Community Center Resiliency Project: General Contractor Services” to the Designated Contact by messenger, overnight courier or certified mail to the following address:

Battery Park City Authority
Attn: Michael LaMancusa
200 Liberty Street, 24th Floor
New York, NY 10281

BPCA is not responsible for late Proposals, no matter the cause. Proposals *must* arrive at the time and place specified herein and be time stamped by BPCA by the Due Date. Please leave ample time for building security. Late Proposals will NOT be accepted. Proposals submitted by fax or electronic transmission will NOT be accepted. A Proposer may, after submitting a Proposal, amend its Proposal by submitting an amended Proposal, clearly labeled “Amended Proposal – Ballfield & Community Center Resiliency Project: General Contractor Services,” as long as the amended Proposal is submitted by the Due Date.

V. **PROPOSAL FORMAT AND CONTENTS**

A. *Proposal Format*

The Proposal must:

- Be printed on 8½” x 11” paper;
- Have numbered pages; and
- Be no longer than ten (10) single-sided pages, exclusive of the Cover Letter, Cost Proposal, and Required Attachments.

B. *Proposal Content*

In addition to the separately sealed Cost Proposal, described in Section VIII. Below, each Proposal must include the following in the order listed:

- 1) Cover Letter, signed by a person within the firm who is authorized to bind the Proposer, which includes representations that:
 - (a) Except as disclosed in the Proposal, no officer or employee of the Proposer is directly or indirectly a party to or in any other manner interested financially or otherwise in this RFP;
 - (b) Proposer satisfies all of the minimum qualification requirements in Section IV.A; and
 - (c) Proposer has reviewed BPCA’s Standard Form of Contract, attached as Exhibit C to this RFP, and either has no objections or has detailed their objections in an appendix to their Proposal.
- 2) Executive Summary.
- 3) Responses to the Questions as well as all of the Information Required (Sections VI.A. and B.).
- 4) Required Attachments (Section VI. C.).

BPCA reserves the right to reject any Proposals that fail to include any required item described in this Section V.B., including Cover Letters that are unsigned or fail to include each of the above representations (including an appendix if there are objections to BPCA’s Standard Form of Contract).

VI. INFORMATION REQUIRED

A. Questions and Information Sought Relating to the Work

- 1) Describe your team's general contracting experience with projects involving metal fabrication, large-scale exterior metal panel and fencing installation, and decorative metalwork.
- 2) Describe your team's general contracting experience with projects involving urban and coastal flood and seepage barrier systems and drainage improvements.
- 3) Describe your team's experience providing contractor services for projects involving public parks, highway and street frontages, open spaces, and outdoor recreation facilities.
- 4) Describe your team's experience managing general contractor projects in physically constrained sites involving complicated adjacencies such as active public spaces, family recreation facilities, state and city-owned streets and rights-of-way, public schools, residential high-rise buildings, and neighboring active construction projects.
- 5) Identify members of your team who have experience performing contractor services for, and interacting with, public agencies on infrastructure and resiliency projects.
- 6) Describe your team's experience with work similar to that required for the Project for other public agencies, authorities, and entities, with an emphasis on New York State and New York City public entities.
- 7) Describe your team's proposed approach and methodology for completing the Project. As part of this description, briefly explain your firm's conceptual step-by-step approach to completing the Project, and outline the proposed procedures for executing the requested services.
- 8) Describe the safety measures and precautions that you intend to implement for the Project.
- 9) Describe your team's proposed means of completing the Project within the prescribed time period.
- 10) List each key member of the team you intend to assign to this engagement and include for each listed individual: (a) area(s) of specialization; (b) title and/or position within your firm; (c) the services to be performed.
- 11) Identify the Project Manager who will be the primary contact and lead personnel in providing services to BPCA, and identify any other persons who will be listed as a "key person" in any contract with BPCA.
- 12) Identify any sub-contractors you intend to use for this engagement, and describe the services to be performed by each sub-consultant.
- 13) Clearly identify any information in your Proposal that you believe to be confidential and exempt from FOIL, and state the reasons. Please note that this question is for informational purposes only, and BPCA will determine whether information or materials are exempt from disclosure under FOIL in its sole discretion.

- 14) **Identify any and all exceptions taken to BPCA's Standard Form of Contract, attached as Exhibit C, and explain the reasons for such exceptions. Such exceptions must be detailed in an appendix to your Proposal labeled, "Appendix: Objections to BPCA Form of Contract." NO EXCEPTIONS TO THE CONTRACT WILL BE CONSIDERED BY BPCA AFTER SUBMISSION OF THE PROPOSALS. BPCA maintains the right to reject Proposals based on non-conformance with the Standard Form of Contract.**
- 15) Provide at least three (3) client references for whom your firm has performed similar work to that requested in this RFP. For each client, describe the project, the project's date, and services performed, and provide the name, address, and telephone number for a person at client's firm familiar with such work.

B. Questions and Information Sought Relating to Proposer's Firm & Eligibility

- 1) Within the past three (3) years, have there been any significant developments in your firm such as changes in ownership or restructuring? Do you anticipate any significant changes in the near future? If so, please describe.
- 2) How does your firm identify and manage conflicts of interest?
- 3) Are there any potential conflict of interest issues posed by your firm's performance of the Work on behalf of BPCA?
- 4) Has your firm or have any of the firm's partners/employees been disciplined or censured by any regulatory body within the last five (5) years? If so, please describe the relevant facts.
- 5) Within the last five (5) years, has your firm, or a partner or employee in your firm, been involved in litigation or other legal proceedings relating to the provision of professional services? If so, please provide an explanation and the current status or disposition of the matter.
- 6) List any professional or personal relationships your firm's employees may have with BPCA's Board Members and/or employees. A list of such Board members and employees is attached to this RFP as Exhibit J.
- 7) If selected, will your firm assign any person to this engagement who was previously an employee of BPCA or BPCPC? If so, please: i) identify when (month and year) that person's employment at BPCA/BPCPC terminated, and ii) describe that person's involvement, if any, with matters related to this RFP during his/her employment at BPCA/BPCPC.
- 8) In the past five (5) years, have any public sector clients terminated their working relationship with your firm? If so, please provide a brief statement of the reasons. Provide the name of the client and provide a contact person, address and telephone number.
- 9) Clearly identify any information in your Proposal that you believe to be confidential and exempt from disclosure under FOIL, and state the reasons. Please note that this question is for informational purposes only, and BPCA will determine whether information or materials are exempt from disclosure under FOIL in its sole discretion.

- 10) Provide at least three (3) client references for whom your firm has performed similar work to that requested in this RFP. For each client, describe the project, the project's date, and services performed, and provide the name, address, and telephone number for a person at client's firm familiar with such work.

C. Required Attachments

- 1) Mandatory Forms:

Each Proposal must include a completed copy of all "Mandatory Forms" found at: www.bpca.ny.gov/wp-content/uploads/2015/03/Vendor-ResponsibilityQuestionnaire.pdf.

The Mandatory Forms include the following:

- a) NYS Standard Vendor Responsibility Questionnaire, notarized and signed by the individual(s) authorized to contractually bind the Proposer, indicating the signer's title/position within the firm.*
- b) State Finance Law § 139 Form 1, signed by the individual(s) authorized to contractually bind the Proposer.*
- c) W-9 form.
- d) Statement of Non-Collusion.
- e) MBE/WBE/SDVOB Utilization Plans. Please note that all such plans must be submitted even if Proposer is a MBE/WBE/SDVOB.

*In addition to the copy required to be included in each bound Proposal, Proposers must additionally provide one (1) unbound, completed original, with ink signatures, of the NYS Standard Vendor Responsibility Questionnaire and SFL 139 Form 1.

- 2) Response to the question regarding the use of New York State businesses set forth in Section XII.
- 3) Completed MBE/WBE and EEO Policy Statement and Diversity Practices Questionnaire (attached as part of Exhibit B).
- 4) Financial Statements:

Provide a copy of your firm's most recent audited financial statements (within the last year). In the event you do not have audited financials you must provide a statement to that effect with your proposal, and summary financial information for the calendar year most recently ended.

- 5) Acknowledgement of Addenda:

Attach a completed and signed Acknowledgement of Addenda Form, attached as Exhibit I, acknowledging receipt of all addenda to this RFP, if any, issued by BPCA before the Due Date. Addenda are posted by BPCA as necessary and can be found on the BPCA website at www.bpca.ny.gov. It is the responsibility of each Proposer to check the BPCA website for addenda and to review addenda prior to submitting any proposal in response to this RFP.

- 6) Appendices:
 - a) Attach professional biographies for all employees identified in your Proposal.
 - b) Attach a project bar chart schedule showing completion dates for key tasks, milestones, etc. and final completion of all Work.
 - c) Identify any and all exceptions taken to BPCA's Standard Form of Contract.

VII. INSURANCE AND BONDS REQUIREMENTS

A. *General Requirements*

The total cost of the required insurance listed in paragraphs B) and C) below, must be incorporated into the Cost Proposal. The additional insured protection afforded BPCA, BPCPC, and the State of New York must be on a primary and non-contributory basis. All policies must include a waiver of subrogation in favor of BPCA, BPCPC, and the State of New York, no policies may contain any limitations / exclusions for New York Labor Law claims, and cross liability coverage must be provided for BPCA, BPCPC, and the State of New York.

All of the carriers that provide the below required insurance must be rated "A-VII" or better by A.M. Best and must provide direct written notice of cancellation or non-renewal to BPCA, BPCPC, and the State of New York at least 30 days before such cancellation or non-renewal is effective, except for cancellations due to non-payment of premium, in which case 10 days written notice is acceptable.

B. *Insurance Requirements for the Selected Proposer*

The selected Proposer will be required to obtain and provide proof of the types and amounts of insurance listed below: (i) as a condition precedent to the award of the contract for the Project; and (ii) continuing throughout the entire Term. The insurance policies listed below must also conform to the applicable terms of the Contract, as shown in BPCA's sample form of contract attached.

- **Commercial General Liability Insurance**, written on ISO Form CG 00 01 or its equivalent and with no modification to the contractual liability coverage provided therein, shall be provided on an occurrence basis and limits shall not be less than:
 - \$5,000,000 per occurrence
 - \$6,000,000 general aggregate which must apply on a per location / per project basis
 - \$6,000,000 products/completed operations aggregate

BPCA, BPCPC, and the State of New York must be protected as additional insureds on ISO Form CG 2010 (11/85) or its equivalent on policies held by the selected Proposer and any of its subcontractors. Should the Proposer's work include construction activities of any kind then the Proposer must maintain Products / Completed Operations coverage for no less than three years after the construction work is completed, and continue to include Additional Insured protection for BPCA, BPCPC & the State of New York for the prescribed timeframe. When providing evidence of insurance, the Proposer must include a completed Acord 855 NY form. Securing the required limits via a combination of primary and umbrella/excess liability policies is allowed. The General Aggregate limit must apply on a per project basis on the primary General Liability policy should a combination of primary and Umbrella/Excess liability policies be utilized to secure the required total limits of coverage.

- **Automobile Liability Insurance** with a combined single limit of not less than \$1,000,000. Coverage must apply to the Proposer's owned, hired, and non-owned vehicles and protect BPCA, BPCPC, and the State of New York as additional insured.
- **Workers' Compensation, Employer's Liability, and Disability Benefits** shall not be less than statutory limits, including United States Longshore and Harbor Workers Act coverage as applicable to the operations of the Proposer.
- **Builder's Risk / Installation Floater Insurance** in an amount not less than 100% of the full contract price. Coverage must be written on ISO Special Form CP 10 30 04 02 or its equivalent on a completed value non-reporting basis and provide coverage for the Proposer, all subcontractors, BPCA, BPCPC, and the State of New York. Coverage must apply to property while on site, off site, and in transit, include an agreed amount provision which eliminates any coinsurance provision, and include BPCA as a loss payee. Coverage must include the insurable interests of all subcontractors retained by the Proposer.

C. Insurance Requirements for all Subcontractors

Any subcontractor(s) utilized by the selected Proposer will be required to obtain the types and amounts of insurance listed below: (i) as a condition of commencing any Work; and (ii) continuing throughout the duration of the subcontractor's Work. The insurance policies listed below must also conform to the applicable terms of the Contract, as shown in BPCA's sample form of contract attached:

- **Commercial General Liability Insurance**, written on ISO Form CG 00 01 or its equivalent and with no modification to the contractual liability coverage provided therein, shall be provided on an occurrence basis and limits shall not be less than:
 - \$1,000,000 per occurrence
 - \$2,000,000 general aggregate which must apply on a per location / per project basis
 - \$2,000,000 products/completed operations aggregate

BPCA, BPCPC, and the State of New York must be protected as additional insureds on ISO Form CG 2010 (11/85) or its equivalent on policies held by all subcontractors. Should the subcontractor's work include construction activities of any kind then the subcontractor must maintain Products / Completed Operations coverage for no less than three years after the construction work is completed and continue to include Additional Insured protection for BPCA, BPCPC & The State of New York for the prescribed timeframe. When providing evidence of insurance, the subcontractor must include a completed Acord 855 NY form.

- **Automobile Liability Insurance** with a combined single limit of not less than \$1,000,000. Coverage must apply to the subcontractor's owned, hired, and non-owned vehicles and protect BPCA, BPCPC, and the State of New York as additional insured.
- **Workers' Compensation, Employer's Liability, and Disability Benefits** shall not be less than statutory limits, including United States Longshore and Harbor Workers Act coverage as applicable to the operations of the subcontractor.

- **Subcontractors will also be required to obtain all other insurances listed in Section (2) unless otherwise approved in writing by BPCA prior to commencement of any Subcontractor’s work.**

D. A payment bond and a performance bond will both be required for this Project. Please provide a letter from your surety(ies) stating that you are able to provide both such bonds, as required in this RFP’s Standard Form of Contract (Exhibit C).

VIII. COST PROPOSAL: FORMAT AND REQUIRED INCLUSIONS

The Cost Proposal must state a lump-sum cost for performance of all Work and include each of the following:

- 1) Proposer must submit with its Cost Proposal, the form of which is annexed hereto as Exhibit D, an itemized cost for the Work, according to the Bid Breakdown (attached to this RFP as Exhibit E). The total sum of these items will be equivalent to the Base Proposal.
- 2) Proposer must submit with its Cost proposal a completed Form of Unit Pricing according to the attached Unit Pricing Form attached to this RFP as Exhibit G as an aid in the evaluation of the reasonableness of Proposer’s lump-sum Cost Proposal and to apply to future change order work, if any.
- 3) Proposer must submit with its Cost Proposal a completed Form of Labor Rates, showing labor rates for all trades, including all costs except overhead and profit. Prices shown should include base hourly rates, overtime rates, insurance and benefits. The Form of Labor Rates is attached to this RFP as Exhibit F.

The Cost Proposal must be submitted in its own separate, sealed envelope within the sealed package containing all other Proposal documents. Please provide six (6) copies of the Cost Proposal.

IX. SELECTION PROCESS

A. Evaluation

Each timely submitted Proposal will be reviewed for compliance with the form and content requirements of this RFP. A committee of BPCA employees selected by BPCA (the “Committee”) will then review and evaluate the Proposals in accordance with the evaluation criteria set forth below. While only Committee members will score the evaluation criteria, the Committee may consult an outside expert for advisement on the evaluation of matters requiring technical expertise. Before final selection, BPCA must determine that the proposed selected Proposer is responsible, in accordance with applicable law and BPCA’s Procurement Guidelines, which may be viewed at: www.bpca.ny.gov/public-information.

B. Interviews

BPCA reserves the right to decide whether to interview any or all of the Proposers. The Committee may conduct interviews for many reasons, including to further assess a Proposer’s ability to perform the Work or provide specific services, or to seek information related to any other evaluation criteria. The proposed Lead PM, as well all other key personnel proposed to perform the Work, must be available to participate in the interview. Failure to be invited for an interview does not indicate that a Proposer is no longer under consideration for the Project.

C. Evaluation Criteria for Selection

Selection will be based upon the following criteria:

1) Technical Evaluation:

- a) General contracting experience with projects involving metal fabrication, large-scale exterior metal panel and fencing installation, and decorative metalwork...20%
- b) General contracting experience with projects involving urban and coastal flood and seepage barrier systems and drainage improvements.....20%
- c) Experience performing construction projects in physically constrained sites involving multiple complicated adjacencies such as heavily used/trafficked parks, public spaces, family recreation facilities, state and city-owned streets and rights-of-way, schools, residential high-rise buildings, and active neighboring construction sites.....20%
- d) Approach to the provision of Services, including staffing, subcontractors, site logistics, and safety measures15%
- e) Project Schedule and Sequencing15%
- f) Response to Diversity Practices Questionnaire.....10%

2) Cost Proposal evaluation.

D. Basis for Contract Award

The Contract will be awarded to the highest technically rated Proposer whose Proposal is determined to be responsive and in the best interests of BPCA, subject to a determination that the Cost Proposal is fair, reasonable, and provides the best value to BPCA given the requirements of the Project.

X. NON-COLLUSION

By submitting a Proposal, each Proposer warrants and represents that any ensuing Contract has not been solicited or secured directly or indirectly in a manner contrary to the laws of the State of New York, and that said laws have not been violated and shall not be violated as they relate to the procurement or the performance of the Contract by any conduct, including the paying or giving of any fee, commission, compensation, gift, or gratuity or consideration of any kind, directly or indirectly, to any member of the board of directors, employee, officer or official of BPCA.

XI. IRAN DIVESTMENT ACT

By submitting a Proposal or by assuming the responsibility of any Contract awarded hereunder, each Proposer certifies that it is not on the “Entities Determined To Be Non-Responsive Bidders/Offerers Pursuant to The New York State Iran Divestment Act of 2012” list (“Prohibited Entities List”) posted on the New York State Office of General Services website at: www.ogs.ny.gov/about/regs/docs/ListofEntities.pdf and further certifies that it will not utilize any subcontractor/consultant that is identified on the Prohibited Entities List on this Contract. The selected Proposer agrees that should it seek to renew or extend any Contract awarded hereunder, it must provide

the same certification at the time the Contract is renewed or extended. The selected Proposer also agrees that any proposed assignee of the Contract will be required to certify that it is not on the Prohibited Entities List before BPCA may approve a request for assignment of the Contract.

During the term of any Contract awarded hereunder, should BPCA receive information that a person (as defined in State Finance Law §165-a) is in violation of the above-referenced certifications, BPCA will review such information and offer the person an opportunity to respond. If the person fails to demonstrate that it has ceased its engagement in the investment activity which is in violation of the New York State Iran Divestment Act of 2012 within 90 days after the determination of such violation, then BPCA shall take such action as may be appropriate and provided for by law, rule, or contract, including, but not limited to, seeking compliance, recovering damages, or declaring the selected Proposer in default of the awarded Contract.

BPCA reserves the right to reject any request for renewal, extension, or assignment for an entity that appears on the Prohibited Entities List prior to the renewal, extension, or assignment of the Contract, and to pursue a responsibility review with the selected Proposer should it appear on the Prohibited Entities List hereafter.

XII. ENCOURAGING USE OF NEW YORK STATE BUSINESSES IN CONTRACT PERFORMANCE

New York State businesses have a substantial presence in State contracts and strongly contribute to the economies of the state and the nation. In recognition of their economic activity and leadership in doing business in New York State, Proposers for this Contract for commodities, services or technology are strongly encouraged and expected to consider New York State businesses in the fulfillment of the requirements of the Contract. Such partnering may be as subcontractors, suppliers, protégés or other supporting roles.

Proposers are strongly encouraged, to the maximum extent practical and consistent with legal requirements, to use responsible and responsive New York State businesses in purchasing commodities that are of equal quality and functionality and in utilizing services and technology. Furthermore, Proposers are reminded that they must continue to utilize small, minority and women-owned businesses, consistent with current State law.

Utilizing New York State businesses in State contracts will help create more private sector jobs, rebuild New York's infrastructure, and maximize economic activity to the mutual benefit of the contractor and its New York State business partners. New York State businesses will promote the contractor's optimal performance under the Contract, thereby fully benefiting the public sector programs that are supported by associated procurements.

Public procurements can drive and improve the State's economic engine through promotion of the use of New York businesses by its contractors. The State therefore expects bidders/proposers to provide maximum assistance to New York businesses in their contracts. The potential participation by all kinds of New York businesses will deliver great value to the State and its taxpayers.

Proposers can demonstrate their commitment to the use of New York State businesses by responding to the question below. Each proposer must include a response to this question with their proposal. Please note that a "yes" response requires supporting information. If yes, identify New York State businesses that will be used and attach identifying information.

Will New York State businesses be used in the performance of this contract? Yes No

EXHIBIT A

SCOPE OF WORK

I. Background and Context

The Battery Park City Ballfield (the “Ballfields” or the “Project Site”) comprise an 85,000 square foot facility located at West Street between Warren and Murray Streets and immediately west of West Street. The Ballfields are open year round and are used by approximately 50,000 people per year. The Battery Park City Community Center (the “Community Center”), currently operated by Asphalt Green, is an approximately 60,000 square foot recreation and fitness facility located at 211 North End Avenue. The Community Center is situated within the cellar and sub-cellar levels of two neighboring residential towers located at 200 and 300 North End Avenue, with its Eastern plaza level bordering the Ballfields.

Due to the peculiar location-specific and elevation-related vulnerabilities of the Ballfields and Community Center, they collectively represent one of the areas within Battery Park City (“BPC”) at greatest risk of storm-related flooding. This risk was sharply underscored during the Manhattan landfall of Superstorm Sandy in 2012 when the recently upgraded artificial turf Ballfields were destroyed and the Community Center was heavily damaged by rushing floodwaters. BPCA’s post-Sandy flood risk assessments have resulted in the formulation of an overall BPC resiliency plan comprised of four (4) distinct resiliency projects. The “Project was devised to address the discrete vulnerabilities of the Ballfields and Community Center on an interim basis, until such time as two (2) of the other, more complex, BPCA resiliency projects (the North BPC Resiliency Project and the South BPC Resiliency Project) are completed, within an expected period of three (3) to five (5) years (longevity of up to ten (10) years for the interim Ballfield solution is targeted.). At that time, the localized protection provided by the Project will no longer be needed and will thereafter be removed.

The Project envisions the construction of an approximately eight hundred (800) linear foot interim flood barrier (the “Ballfield Barrier System”) along the northern, eastern, and southern boundaries of the Ballfields (Warren Street, West Street/South Route 9a, and Murray Street, respectively) (the “Project Site”) in order to provide flood risk reduction to the Ballfields and the Community Center for up to ten (10) years. The Ballfield Barrier System will provide flood protection for both the Ballfields and the Community Center. Separate additional flood protection measures for the Community Center may be implemented by BPCA through a separate construction project. Any such additional Community Center-focused measures are not included in the Scope of Work for this Project.

The Ballfield Barrier System will comprise a continuous reinforced concrete grade beam; 1-inch thick steel plates, spanning twenty-four (24) feet between the existing fence posts, and decorative panels that will attach to the exterior face of the steel panels. The concrete grade beam will be constructed in a manner that will incorporate the existing fence footings at the entire perimeter of the Ballfields. The majority of the Ballfield Barrier System will comprise steel plate segments that will each be 24-feet long, except in the areas of the flood barrier where the Ballfields’ existing fence (the “Ballfields Fence”) is eight (8)-feet tall. In those areas, the steel plate segments will be 8-feet long. The portion of the Ballfield Barrier System at the Project Site’s southeast corner, at the intersection of Murray Street and South Route 9A/West Street, will be composed of cast-in-place concrete. The geographic limits of the portion of the Ballfield Barrier System that is cast-in-place concrete, will match the limits of the Project Site’s enclosed electrical equipment area in order to provide flood protection to the Project Site’s otherwise vulnerable electrical equipment during a storm event. There is an aesthetic component to the Project that includes decorative aluminum cladding that will be installed over the steel plate using clips and designed with a colored backdrop.

II. Scope Elements

The selected Proposer will provide all necessary labor, materials and equipment, and will perform all work required for completion of the Project, including, but not limited to, the following tasks, in accordance with the Construction Documents:

- a) Perform a detailed pre-construction survey of the Project Site including the Ballfields Fence, and provide a survey report, including documentation of the location of all utilities located beneath the surface of the Project Site and its surroundings.
- b) Promptly contact all utility companies with service to or adjacent to the Project Site to coordinate and secure approvals for the excavation work necessary for the Project.
- c) Promptly apply for and obtain all governmental permits and approvals required to perform the Project.
- d) Mobilize to the Project Site, and provide and install temporary fencing and/or barricades to safely isolate active work areas from the publicly accessible areas (in accordance with the Construction Documents).
- e) Install suitable soil erosion and sediment control measures for the duration of the Project's construction phase.
- f) Perform Project Site demolition as required by the Construction Documents, including but not limited to the removal of existing concrete sidewalks, paving, curbs, and sub-base.
- g) Remove and store existing concrete NYPD barriers within the Project Site, to be reinstalled as part of the Project.
- h) Remove and store sections of the Ballfield Fence within the Project Site, to be reinstalled as part of the Project.
- i) Remove and dispose of in accordance with applicable law existing steel fence posts, and install the larger replacement posts as specified by the Construction Documents.
- j) Remove and dispose of ten (10) trees, as designated by the Construction Documents, including stumps and roots.
- k) Remove the existing walkway pavers along the West Street Pedestrian path, salvaging the bluestone pavers for reuse if possible. Regrade the path at the designated pitch.
- l) Excavate and trench along the base of the existing fencing in order to build the required concrete forms, and place reinforcing steel bars and concrete for construction of the concrete grade beam at the base of the Ballfield Fence (the metal floodwall will be embedded in the concrete grade beam).
- m) Fabricate, furnish, and install steel panels that will constitute the floodwall and decorative aluminum metal panels atop the concrete grade beam, including welding to existing Ballfield Fence posts. This steel panel wall will be coupled with a decorative aluminum panel for the entire length of the flood wall.
- n) Prior to metal panel installation, install one mock-up panel for BPCA approval. The mock-up will be attached to fence posts and will include the steel panel, the decorative panel and all associated attachments.
- o) The wall construction will change to 12-inch-thick, 6-foot-high reinforced concrete wall and footing at the southeast corner of the Project Site (at the intersection of Murray and West Streets). Its extents will match the extents of the existing electrical equipment area.
- p) Furnish and install all sub-base material, concrete sidewalk, paving, and curbs in accordance with the Construction Documents.
- q) Furnish and install three (3) flood gates (one vehicular and two (2) pedestrian) at existing ballfield entrances specified in the Construction Documents.
- r) Furnish and install ten (10) new trees as specified by the Construction Documents as replacements to those previously removed.
- s) Upon substantial completion of the Project, perform and complete all punch-list items as specified by the Project design team and close out all open permits.
- t) Remove any materials, equipment and debris from the Project Site and de-mobilize.

III. General Considerations

- a) The selected Proposer must establish construction boundaries and safety measures at the Project Site that will allow the Ballfields to remain open with minimal, if any, disruption for the duration of the Project.
- b) Time is of the essence in the performance of the Project in order that the Barrier System will be in effect prior to the height of the 2020 hurricane season. In order to expedite completion of the Project, it is expected that the selected Proposer will fully maximize opportunities to undertake concurrent work in multiple locations within the Project Site.
- c) The Project Site is quite constrained, with highly-trafficked public areas, recreation facilities, schools, residences, and busy streets and highways in the immediate area, as well as a construction and waterproofing project that will be in process at the Community Center and the Ballfield Terrace, immediately to the west of the Project Site. Site logistics, coordination and safety will be of paramount importance, and, prior to commencement of the Project, the selected Proposer must submit for BPCA approval a site logistics plan and a Project safety plan, which will be regularly updated during the course of the Project.

EXHIBIT B

CONTRACTOR REQUIREMENTS AND PROCEDURES FOR PARTICIPATION BY NEW YORK STATE-CERTIFIED MBEs/WBEs/SDVOBs AND EQUAL EMPLOYMENT OPPORTUNITIES FOR MINORITY GROUP MEMBERS AND WOMEN

NEW YORK STATE LAW

Pursuant to New York State Executive Law Article 15-A and Parts 140-145 of Title 5 of the New York Codes, Rules and Regulations BPCA is required to promote opportunities for the maximum feasible participation of New York State-certified MBEs/WBEs (collectively, “MWBE(s)”) and the employment of minority group members and women in the performance of BPCA contracts. Pursuant to New York State Executive Law Article 17-B and 9 NYCRR §252, BPCA recognizes its obligation under the law to promote opportunities for maximum feasible participation of certified SDVOBs.

Business Participation Opportunities for MWBEs

For purposes of this solicitation, BPCA hereby establishes the following MWBE participation goals, based on the current availability of MWBEs:

Overall goal for total MWBE participation: 30%

NYS-Certified Minority-Owned Business (“MBE”) Participation: 15%

NYS-Certified Women-Owned Business (“WBE”) Participation: 15%

A contractor (“Contractor”) on any contract resulting from this procurement (“Contract”) must document its good faith efforts to provide meaningful participation by MWBEs as subcontractors and suppliers in the performance of the Contract. To that end, by submitting a response to this RFP, the Proposer agrees that BPCA may withhold payment pursuant to any Contract awarded as a result of this RFP pending receipt of the required MWBE documentation. The directory of MWBEs can be viewed at: www.ny.newnycontracts.com. For guidance on how BPCA will evaluate a Contractor’s “good faith efforts,” refer to 5 NYCRR § 142.8.

The Proposer understands that only sums paid to MWBEs for the performance of a commercially useful function, as that term is defined in 5 NYCRR § 140.1, may be applied towards the achievement of the applicable MWBE participation goal. The portion of a contract with an MWBE serving as a broker that shall be deemed to represent the commercially useful function performed by the MWBE shall be 25 percent of the total value of the contract.

In accordance with 5 NYCRR § 142.13, the Proposer further acknowledges that if it is found to have willfully and intentionally failed to comply with the MWBE participation goals set forth in a Contract resulting from this RFP, such finding constitutes a breach of contract and BPCA may withhold payment as liquidated damages.

Such liquidated damages shall be calculated as an amount equaling the difference between: (1) all sums identified for payment to MWBEs had the Contractor achieved the contractual MWBE goals; and (2) all sums actually paid to MWBEs for work performed or materials supplied under the Contract.

By submitting a bid or proposal, a Proposer agrees to demonstrate its good faith efforts to achieve the applicable MWBE participation goals by submitting evidence thereof through the New York State Contract System (“NYSCS”), which can be viewed at www.ny.newnycontracts.com, provided, however, that a Proposer may arrange to provide such evidence via a non-electronic method by contacting Justin McLaughlin-Williams at justin.mclaughlin-williams@bpcanyc.gov or 212-417-2337. Please note that the NYSCS is a one-stop solution for all of your

MBE/WBE and Article 15-A contract requirements. For additional information on the use of the NYSCS to meet the Proposer's MBE/WBE requirements, please see the attached MBE/WBE guidance from the New York State Division of Minority and Women's Business Development, "Your MWBE Utilization and Reporting Responsibilities Under Article 15-A."

Additionally, a Proposer will be required to submit the following documents and information as evidence of compliance with the foregoing:

- A. An MWBE Utilization Plan with their bid or proposal. Any modifications or changes to an accepted MWBE Utilization Plan after the Contract award and during the term of the Contract must be reported on a revised MWBE Utilization Plan and submitted to BPCA for review and approval.
- B. BPCA will review the submitted MWBE Utilization Plan and advise the Proposer of BPCA acceptance or issue a notice of deficiency within 30 days of receipt.
- C. If a notice of deficiency is issued, the Proposer will be required to respond to the notice of deficiency within seven (7) business days of receipt by submitting to Michael LaMancusa at BPCA, by email at michael.lamancusa@bpca.ny.gov, a written remedy in response to the notice of deficiency. If the written remedy that is submitted is not timely or is found by BPCA to be inadequate, BPCA shall notify the Proposer and direct the Proposer to submit, within five (5) business days, a request for a partial or total waiver of MWBE participation goals. Failure to file the waiver form in a timely manner may be grounds for disqualification of the bid or proposal.
- D. BPCA may disqualify a Proposer as being non-responsive under the following circumstances:
 - 1) If a Proposer fails to submit an MWBE Utilization Plan;
 - 2) If a Proposer fails to submit a written remedy to a notice of deficiency;
 - 3) If a Proposer fails to submit a request for waiver; or
 - 4) If BPCA determines that the Proposer has failed to document good faith efforts.

The successful Proposer will be required to attempt to utilize, in good faith, any MBE or WBE identified within its MWBE Utilization Plan, during the performance of the Contract. Requests for a partial or total waiver of established goal requirements made subsequent to Contract Award may be made at any time during the term of the Contract to BPCA, but must be made no later than prior to the submission of a request for final payment on the Contract.

The successful Proposer will be required to submit a quarterly M/WBE Contractor Compliance & Payment Report to BPCA, by the 10th day following each end of quarter over the term of the Contract documenting the progress made toward achievement of the MWBE goals of the Contract.

Business Participation Opportunities for SDVOBs

For purposes of this solicitation, BPCA hereby establishes an overall goal of 6% for SDVOB participation. A Proposer must document good faith efforts to provide meaningful participation by SDVOBs as subcontractors or suppliers in the performance of the Contract and Proposer agrees that BPCA may withhold payment pending receipt of the required SDVOB documentation. The directory of New York State Certified SDVOBs can be viewed at: http://www.ogs.ny.gov/Core/docs/CertifiedNYS_SDVOB.pdf. For guidance on how BPCA will determine a Contractor's "good faith efforts," refer to 9 NYCRR §252.2(f)(2).

In accordance with 9 NYCRR §252.2(s), the Proposer acknowledges that if it is found to have willfully and intentionally failed to comply with the SDVOB participation goals set forth in the Contract, such finding constitutes a breach of Contract and Contractor shall be liable for damages as specified in the Contract.

Such damages shall be calculated based on the actual cost incurred by BPCA related to BPCA's expenses for personnel, supplies and overhead related to establishing, monitoring and reviewing certified SDVOB programmatic goals.

- A. Additionally, a Proposer agrees to submit a Utilization Plan with their bid or Proposal as evidence of compliance with the foregoing. Any modifications or changes to the Utilization Plan after the Contract award and during the term of the Contract must be reported on a revised Utilization Plan and submitted to BPCA.
- B. BPCA will review the submitted Utilization Plan and advise the Proposer of BPCA's acceptance or issue a notice of deficiency within 30 days of receipt.
- C. If a notice of deficiency is issued, Proposer agrees that it shall respond to the notice of deficiency within seven (7) business days of receipt by submitting to Michael LaMancusa at BPCA, by email at michael.lamancusa@bpcanyc.gov, a written remedy in response to the notice of deficiency. If the written remedy that is submitted is not timely or is found by BPCA to be inadequate, BPCA shall notify the Proposer and direct the Proposer to submit, within five (5) business days, a request for a partial or total waiver of SDVOB participation goals. Failure to file the waiver form in a timely manner may be grounds for disqualification of the bid or Proposal.
- D. BPCA may disqualify a Proposer as being non-responsive under the following circumstances:
 - 1) If a Proposer fails to submit a Utilization Plan;
 - 2) If a Proposer fails to submit a written remedy to a notice of deficiency;
 - 3) If a Proposer fails to submit a request for waiver; or
 - 4) If BPCA determines that the Proposer has failed to document good faith efforts.

The successful Proposer shall attempt to utilize, in good faith, any SDVOB identified within its Utilization Plan, during the performance of the Contract. Requests for a partial or total waiver of established goal requirements made subsequent to the Contract award may be made at any time during the term of the Contract to BPCA, but must be made no later than prior to the submission of a request for final payment on the Contract.

The successful Proposer is required to submit a Contractor's SDVOB Contractor Compliance & Payment Report to BPCA on a monthly basis over the term of the Contract documenting the progress made toward achievement of the SDVOB goals of the Contract.

Equal Employment Opportunity Requirements

By submission of a bid or proposal in response to this solicitation, the Proposer agrees with all of the terms and conditions of the attached MWBE Equal Employment Opportunity Policy Statement. The Proposer is required to ensure that it and any subcontractors awarded a subcontract for the construction, demolition, replacement, major repair, renovation, planning or design of real property and improvements thereon (the "Work"), except where the Work is for the beneficial use of the Proposer, undertake or continue programs to ensure that minority group members and women are afforded equal employment opportunities without discrimination because of race, creed, color, national origin, sex, age, disability or marital status. For these purposes, equal opportunity shall apply in the areas of recruitment, employment, job assignment, promotion, upgrading, demotion, transfer, layoff, termination, and rates of pay or other forms of compensation. This requirement does not apply to: (i) work, goods, or services unrelated to the Contract; or (ii) employment outside New York State.

The Proposer will be required to submit a Minority and Women-owned Business Enterprise and Equal Employment Opportunity Policy Statement, Form # 4, to BPCA with its bid or proposal.

If awarded a Contract, Proposer shall submit a Workforce Utilization Report and shall require each of its Subcontractors to submit a Workforce Utilization Report, in such format as shall be required by BPCA on a monthly basis during the term of the Contract.

Pursuant to Executive Order #162, contractors and subcontractors will also be required to report the gross wages paid to each of their employees for the work performed by such employees on the contract utilizing the Workforce Utilization Report on a quarterly basis.

Further, pursuant to Article 15 of the Executive Law (the "Human Rights Law"), all other State and Federal statutory and constitutional non-discrimination provisions, the Contractor and sub-contractors will not discriminate against any employee or applicant for employment because of race, creed (religion), color, sex, national origin, sexual orientation, military status, age, disability, predisposing genetic characteristic, marital status or domestic violence victim status, and shall also follow the requirements of the Human Rights Law with regard to non-discrimination on the basis of prior criminal conviction and prior arrest.

Please Note: Failure to comply with the foregoing requirements may result in a finding of non-responsiveness, non-responsibility and/or a breach of the Contract, leading to the withholding of funds, suspension or termination of the Contract or such other actions or enforcement proceedings as allowed by the Contract.



Your MBE/WBE Utilization and Reporting Responsibilities Under Article 15-A

The New York State Contract System (“NYSCS”) is your one stop tool compliance with New York State’s MBE/WBE Program. It is also the platform New York State uses to monitor state contracts and MBE/WBE participation.

GETTING STARTED

To access the system, please login or create a user name and password at www.ny.newnycontracts.com/FrontEnd/VendorSearchPublic.asp?TN=ny&XID=7562. If you are uncertain whether you already have an account set up or still need to register, please send an email to the customer service contact listed on the Contact Us & Support page, or reach out to Justin McLaughlin-Williams at justin.mclaughlin-williams@bpca.ny.gov or 212-417-2337. For verification, in the email, include your business name and contact information.

VENDOR RESPONSIBILITIES

As a vendor conducting business with New York State, you have a responsibility to utilize minority- and/or women-owned businesses in the execution of your contracts, per the MBE/WBE percentage goals stated in your solicitation, incentive proposal or contract documents. NYSCS is the tool that New York State uses to monitor MBE/WBE participation in state contracting. Through the NYSCS you will submit utilization plans, request subcontractors, record payments to subcontractors, and communicate with your project manager throughout the life of your awarded contracts.

There are several reference materials available to assist you in this process, but to access them, you need to first be registered within the NYSCS. Once you log onto the website, click on the **Help & Support** >> link on the lower left hand corner of the Menu Bar to find recorded trainings and manuals on all features of the NYSCS. You may also click on the **Help & Tools** icon at the top right of your screen to find videos tailored to primes and subcontractors. There are also opportunities available to join live trainings, read up on the “Knowledge Base” through the Forum link, and submit feedback to help improve future enhancements to the system. Technical assistance is always available through the **Contact Us & Support** link on the NYSCS website (www.ny.newnycontracts.com/FrontEnd/VendorSearchPublic.asp?TN=ny&XID=7562).

For more information, contact Justin McLaughlin-Williams at justin.mclaughlin-williams@bpca.ny.gov or 212-417-2337.

MINORITY AND WOMEN-OWNED BUSINESS ENTERPRISES

EQUAL EMPLOYMENT OPPORTUNITY POLICY STATEMENT

MBE/WBE AND EEO POLICY STATEMENT

I, _____ (the "Contractor"), agree to adopt the following policies with respect to the project being developed at, or services rendered to, the Battery Park City Authority ("BPCA").

MBE/WBE This organization will and will cause its contractors and subcontractors to take good faith actions to achieve the MBE/WBE contract participations goals set by the State for that area in which the State-funded project is located, by taking the following steps:

- (1) Actively and affirmatively soliciting bids for contracts and subcontracts from qualified State certified MBEs or WBEs, including solicitations to MBE/WBE contractor associations.
- (2) Requesting a list of State-certified MBEs/WBEs from BPCA and soliciting bids from these MBEs/WBEs directly.
- (3) Ensuring that plans, specifications, request for proposals and other documents used to secure bids will be made available in sufficient time for review by prospective MBEs/WBEs.
- (4) Where feasible, dividing the work into smaller portions to enhance participations by MBEs/WBEs and encourage the formation of joint venture and other partnerships among MBE/WBE contractors to enhance their participation.
- (5) Documenting and maintaining records of bid solicitation, including those to MBEs/WBEs and the results thereof. The Contractor will also maintain records of actions that its subcontractors have taken toward meeting MBE/WBE contract participation goals.
- (6) Ensuring that progress payments to MBEs/WBEs are made on a timely basis so that undue financial hardship is avoided, and that bonding and other credit requirements are waived or appropriate alternatives are developed to encourage MBE/WBE participation.

EEO (a) This organization will not discriminate against any employee or applicant for employment because of race, creed, color, national origin, sex, age, disability or marital status, will undertake or continue existing diversity programs to ensure that minority group members are afforded equal employment opportunities without discrimination, and will make and document its conscientious and active efforts to employ and utilize minority group members and women in its work force on State contracts.

- (b) This organization will state in all solicitation or advertisements for employees that in the performance of the State contract all qualified applicants will be afforded equal employment opportunities without discrimination because of race, creed, color, national origin, sex disability or marital status.
- (c) At the request of BPCA, this organization will request that each employment agency, labor union, or authorized representative will not discriminate on the basis of race, creed, color, national origin, sex, age, disability or marital status and that such union or representative will affirmatively cooperate in the implementation of this organization's obligations herein.
- (d) The Contractor will comply with the provisions of the Human Rights Law, all other State and Federal statutory and constitutional non-discrimination provisions. The Contractor and subcontractors will not discriminate against any employee or applicant for employment because of race, creed (religion), color, sex, national origin, sexual orientation, military status, age, disability, predisposing genetic characteristic, marital status or domestic violence victim status, and will also follow the requirements of the Human Rights Law with regard to non-discrimination on the basis of prior criminal conviction and prior arrest.
- (e) This organization will include the provisions of sections (a) through (d) of this agreement in every subcontract in such a manner that the requirements of the subdivisions will be binding upon each subcontractor as to work in connection with the State contract.

Battery Park City Authority Request For Proposals

Agreed to this _____ day of _____, 20__

By _____

Print: _____ Title: _____

_____ is designated as the Consultant's Minority Business Enterprise Liaison responsible for administering the Minority and Women-Owned Business Enterprises - Equal Employment Opportunity (MBE/WBE - EEO) program.

MBE/WBE Contract Goals

30% Minority and Women's Business Enterprise Participation

___% Minority Business Enterprise Participation

___% Women's Business Enterprise Participation

EEO Contract Goals (if applicable)

___% Minority Labor Force Participation

___% Female Labor Force Participation

(Authorized Representative)

Title: _____

Date: _____

Diversity Practices Questionnaire

I, _____, as _____ (title) of _____ company (the “Company”), swear and/or affirm under penalty of perjury that the answers submitted to the following questions are complete and accurate to the best of my knowledge:

1. Does your Company have a Chief Diversity Officer or other individual who is tasked with supplier diversity initiatives? Yes or No

If Yes, provide the name, title, description of duties, and evidence of initiatives performed by this individual or individuals.

2. What percentage of your Company’s gross revenues (from your prior fiscal year) was paid to New York State certified MBEs/WBEs as subcontractors, suppliers, joint-ventures, partners or other similar arrangement for the provision of goods or services to your Company’s clients or customers?

3. What percentage of your Company’s overhead (i.e. those expenditures that are not directly related to the provision of goods or services to your Company’s clients or customers) or non-contract-related expenses (from your prior fiscal year) was paid to New York State certified MBEs/WBEs as suppliers/contractors?¹

4. Does your Company provide technical training² to MBEs/WBEs? Yes or No

If Yes, provide a description of such training which should include, but not be limited to, the date the program was initiated, the names and the number of MBEs/WBEs participating in such training, the number of years such training has been offered and the number of hours per year for which such training occurs.

5. Is your Company participating in a government approved M/WBE mentor-protégé program?

If Yes, identify the governmental mentoring program in which your Company participates and provide evidence demonstrating the extent of your Company’s commitment to the governmental mentoring program.

6. Does your Company include specific quantitative goals for the utilization of MBEs/WBEs in its non-government procurements? Yes or No

If Yes, provide a description of such non-government procurements (including time period, goal, scope and dollar amount) and indicate the percentage of the goals that were attained.

7. Does your Company have a formal M/WBE supplier diversity program? Yes or No

If Yes, provide documentation of program activities and a copy of policy or program materials.

8. Does your Company plan to enter into partnering or subcontracting agreements with New York State certified MBEs/WBEs if selected as the successful Proposer? Yes or No

¹ Do not include onsite project overhead.

² Technical training is the process of teaching employees how to more accurately and thoroughly perform the technical components of their jobs. Training can include technology applications, products, sales and service tactics, and more. Technical skills are job-specific as opposed to soft skills, which are transferable.

If Yes, complete the attached Utilization Plan

All information provided in connection with the Diversity Practices Questionnaire is subject to audit and any fraudulent statements are subject to criminal prosecution and debarment.

Signature of
Owner/Official _____
Printed Name of
Signatory _____
Title _____
Name of Business _____
Address _____
City, State, Zip _____

STATE OF _____

COUNTY OF _____) ss:

On the _____ day of _____, 20____, before me, the undersigned, a Notary Public in and for the State of _____, personally appeared _____, personally known to me or proved to me on the basis of satisfactory evidence to be the individual whose name is subscribed to this certification and said person executed this instrument.

Notary Public

EXHIBIT C

(BPCA Standard Form of Contract)

(attached)

[NO FURTHER TEXT ON THIS PAGE]

CONSTRUCTION AGREEMENT

between

HUGH L. CAREY BATTERY PARK CITY AUTHORITY

and

[NAME OF COMPANY, INC. CORP, CO.]

Dated as of **[DATE]**

Contract No. **[ENTER CONTRACT NUMBER]**

(PROJECT NAME)

TABLE OF CONTENTS

Contents

ARTICLE 1 - DEFINITIONS 1

ARTICLE 2 - SCOPE OF WORK, MATERIALS AND LABOR 4

 2.1 *DEFINITION OF WORK*..... 4

 2.2 *CONTRACT DOCUMENTS* 4

 2.3 *INTENT OF CONTRACT DOCUMENTS*..... 4

 2.4 *COMPLETION OF DRAWINGS AND SPECIFICATIONS* 6

 2.5 *TITLE TO MATERIALS* 6

 2.6 *CONTRACTOR’S OBLIGATIONS* 6

 2.7 “*OR EQUAL*” *CLAUSE*..... 7

 2.8 *QUALITY AND LABELING* 8

ARTICLE 3 - COMMENCEMENT AND COMPLETION OF THE WORK 9

 3.1 *COMMENCEMENT, COMPLETION AND PROGRESS SCHEDULE* 9

 3.2 *COORDINATION WITH OTHER CONTRACTORS* 11

 3.3 *NOTICE OF DELAY*..... 11

 3.4 *EXTENSION OF TIME*..... 12

ARTICLE 4 - CONTRACT PRICE 12

ARTICLE 5 - METHOD, SCHEDULE AND TERMS OF PAYMENTS 13

 5.1 *PARTIAL PAYMENT* 13

 5.2 *REQUISITIONS* 13

 5.3 *TRADE PAYMENT BREAKDOWN* 13

 5.4 *PAYMENT FOR STORED MATERIALS* 13

 5.5 *RECEIPTS AND RELEASES OF LIENS* 14

 5.6 *TIME OF PAYMENT* 14

 5.7 *REDUCTION OF RETAINAGE* 15

 5.8 *FINAL PAYMENT* 15

 5.9 *RELEASE AND CONSENT OF SURETY* 15

 5.10 *BPCA’S RIGHT TO AUDIT AND INSPECT RECORDS* 15

 5.11 *WITHHOLDING OF PAYMENTS* 16

ARTICLE 6 – CONTRACTOR..... 16

 6.1 *SUPERINTENDENCE BY CONTRACTOR, DISCIPLINE AND EMPLOYEE SKILLS* 16

6.2	<i>REPRESENTATIONS AND WARRANTIES</i>	17
6.3	<i>VERIFYING DIMENSIONS AND SITE CONDITIONS</i>	17
6.4	<i>COPIES OF CONTRACT DOCUMENTS FOR CONTRACTOR</i>	18
6.5	<i>MEETINGS</i>	18
6.6	<i>RELATED WORK</i>	18
6.7	<i>SURVEYS AND LAYOUT</i>	18
6.8	<i>REPORTS AND ACCESS</i>	18
6.9	<i>FINANCIAL INFORMATION</i>	18
ARTICLE 7 - CONTRACT ADMINISTRATION		18
7.1	<i>ARCHITECT’S RESPONSIBILITIES AND FUNCTIONS</i>	18
7.2	<i>CONSTRUCTION MANAGER’S RESPONSIBILITIES AND FUNCTIONS</i>	19
7.3	<i>SCOPE OF RESPONSIBILITY OF ARCHITECT AND CONSTRUCTION MANAGER</i>	19
ARTICLE 8 - INSPECTION AND ACCEPTANCE		19
8.1	<i>ACCESS TO THE WORK</i>	19
8.2	<i>NOTICE OF REQUIRED INSPECTIONS AND TESTS</i>	19
8.3	<i>ADDITIONAL INSPECTIONS AND TESTS</i>	19
8.4	<i>UNCOVERING OF WORK</i>	20
8.5	<i>CORRECTION OF WORK</i>	20
8.6	<i>CERTIFICATE OF SUBSTANTIAL COMPLETION</i>	20
8.7	<i>COMPLETION OF WORK AND ACCEPTANCE</i>	21
ARTICLE 9 - CHANGES IN THE WORK		21
9.1	<i>CHANGE ORDERS</i>	21
9.2	<i>CHANGE IN CONTRACT PRICE AND TIME</i>	22
9.3	<i>FIELD ORDERS</i>	23
9.4	<i>CHANGED CONDITIONS</i>	23
ARTICLE 10 - SUBCONTRACTS AND PURCHASE ORDERS		24
10.1	<i>SELECTION OF SUBCONTRACTORS AND MATERIALMEN AND APPROVAL OF SUBCONTRACTS AND PURCHASE ORDERS</i>	24
10.2	<i>ACCESS BY BPCA AND OTHERS</i>	24
10.3	<i>RETAINAGE</i>	25
10.4	<i>MISCELLANEOUS</i>	25
ARTICLE 11 - ASSIGNMENT		25
11.1	<i>NO ASSIGNMENT OF DUTIES</i>	25

11.2	<i>NO ASSIGNMENT OF MONIES</i>	26
11.3	<i>ASSIGNMENT BY BPCA</i>	26
	ARTICLE 12 - MECHANICS' LIENS AND CLAIMS	26
	ARTICLE 13 – INSURANCE AND CONTRACT SECURITY	27
13.1	<i>INSURANCE</i>	27
13.2	<i>EFFECT OF PROCUREMENT OF INSURANCE</i>	31
13.3	<i>CONTRACT SECURITY</i>	31
13.4	<i>ADDITIONAL OR SUBSTITUTE BOND</i>	31
	ARTICLE 14 - CLAIMS FOR EXTRA WORK	31
	ARTICLE 15 - TERMINATION	32
15.1	<i>TERMINATION FOR CAUSE</i>	32
15.2	<i>TERMINATION FOR CONVENIENCE OF BPCA</i>	34
15.3	<i>SUSPENSION OF WORK</i>	35
	ARTICLE 16 - COMPOSITE DRAWINGS AND COOPERATION	35
	ARTICLE 17 - PROTECTION OF RIGHTS, PERSONS AND PROPERTY	36
17.1	<i>ACCIDENT PREVENTION</i>	36
17.2	<i>SAFETY PROGRAMS</i>	36
17.3	<i>PROTECTION OF WORK AND PROPERTY</i>	36
17.4	<i>ADJOINING PROPERTY</i>	37
17.5	<i>RISKS ASSUMED BY CONTRACTOR</i>	37
	ARTICLE 18 - USE PRIOR TO ACCEPTANCE BY BPCA	38
	ARTICLE 19 - EXEMPTION FROM SALES AND COMPENSATING USE TAXES	38
19.1	<i>BPCA EXEMPT</i>	38
19.2	<i>CERTIFICATES</i>	38
	ARTICLE 20 - WARRANTIES AND GUARANTIES	38
20.1	<i>IN GENERAL</i>	38
20.2	<i>ADDITIONAL GUARANTIES</i>	39
20.3	<i>REPAIR BY ANOTHER</i>	39
	ARTICLE 21 - INDEMNITY	39
21.1	<i>DELAY OR FAILURE</i>	39
21.2	<i>INVENTIONS</i>	40
21.3	<i>LIABILITY</i>	40
	ARTICLE 22 - PATENTS AND ROYALTIES	40

ARTICLE 23 - AS-BUILT DRAWINGS.....	41
ARTICLE 24 - SHOP DRAWINGS AND SAMPLES	42
24.1 CONTRACTOR SUBMITTAL.....	42
24.2 CONTRACTOR’S RESPONSIBILITY.....	42
ARTICLE 25 – NOTICES.....	42
ARTICLE 26 – EMPLOYMENT AND DIVERSITY	43
26.1 PARTICIPATION BY MINORITY AND WOMEN-OWNED BUSINESS ENTERPRISES.....	43
26.2 PARTICIPATION BY SERVICE-DISABLED VETERAN-OWNED BUSINESSES	48
ARTICLE 27 - STANDARD PROVISIONS	51
27.1 PROVISION REQUIRED BY LAW DEEMED INSERTED.....	51
27.2 COMPLIANCE WITH LAWS, RULES AND REGULATIONS	51
27.3 APPLICABLE LAW, FORUM AND JURISDICTION	51
27.4 NO THIRD PARTY RIGHTS	52
27.5 EXCULPATION; LIMITATION OF LIABILITY	52
27.6 PROTECTION OF LIVES AND HEALTH.....	52
27.7 WAIVER OF IMMUNITY CLAUSE	52
27.8 PROHIBITED INTERESTS.....	53
27.9 LABOR PROVISIONS	53
27.10 DISPUTES RESOLUTION PROCEDURE	55
27.11 ADDITIONAL PROVISIONS RELATING TO THE PROSECUTION OF CLAIMS FOR MONEY DAMAGES	56
27.12 LIMITATION ON ACTIONS	57
27.13 WAIVER OF REMEDIES.....	57
27.14 MODIFICATION OF AGREEMENT	58
27.15 SIGNS AND PARKING.....	58
27.16 ENTIRE AGREEMENT	58
27.17 RIGHTS AND REMEDIES	58
27.18 PARTICIPATION IN INTERNATIONAL BOYCOTT PROHIBITED	58
27.19 COMPLIANCE WITH “BUY-AMERICAN” STATUTES	59
27.20 PERMITTED SUCCESSORS	59
27.21 MACBRIDE FAIR EMPLOYMENT PRINCIPLES	59
27.22 IRAN DIVESTMENT ACT.....	59
27.23 TERMINATION FOR FAILURE TO DISCLOSE UNDER STATE FINANCE LAW §139K	59

27.24	<i>LABOR PEACE</i>	59
27.25	<i>COMPTROLLER'S APPROVAL</i>	60
27.26	<i>KEY PERSON/PERSONNEL</i>	60
27.27	<i>FORM OF AGREEMENT NOT AN OFFER</i>	60
27.28	<i>GENERAL RESPONSIBILITY</i>	60

EXHIBITS

- EXHIBIT A - SCOPE OF WORK
- EXHIBIT B - DRAWINGS
- EXHIBIT C - SPECIFICATIONS
- EXHIBIT D - MONTHLY UTILIZATION COMPLIANCE REPORTS
- EXHIBIT E - PROMPT PAYMENT POLICY
- EXHIBIT F - INCIDENT REPORT FORM

CONSTRUCTION AGREEMENT

AGREEMENT made as of _____ by and between BATTERY PARK CITY AUTHORITY, d/b/a HUGH L. CAREY BATTERY PARK CITY AUTHORITY, (“**BPCA**”), a body corporate and politic, constituting a public benefit corporation and having a place of business at 200 Liberty Street, 24th Floor, New York, New York 10281, and [NAME OF COMPANY], formed under the laws of the State of [STATE], having an office at [Street Address, City, Zip Code] (“**Contractor**”).

W I T N E S S E T H:

WHEREAS, BPCA has fee title to certain real property located in the City, County and State of New York, generally consisting of approximately 92 acres of land located on the west side of lower Manhattan, bounded by Pier A to the South, the westerly extension of Reade Street to the North, the United States Bulkhead Line to the East and the United States Pierhead Line to the West (collectively, “**Battery Park City**”); and

WHEREAS, BPCA has caused the staged development of Battery Park City, in individual parcels, creating a richly diversified mixed use community providing residential and commercial space, with related amenities such as parks, plazas, recreational areas and a waterfront esplanade; and

WHEREAS, BPCA intends to hire a contractor to perform [type of services], consisting of the Work, as hereinafter defined, for the [structure] upon which work will be performed (the “**Project**”), located in and adjacent to [location], in Battery Park City, in the Borough of Manhattan, County, City and State of New York (the “**Site**”); and

WHEREAS, Contractor has been selected to perform the Work, upon the terms and conditions hereinafter provided; and

NOW, THEREFORE, in consideration of the mutual covenants hereinafter set forth, Contractor and BPCA hereby agree as follows:

ARTICLE 1 - DEFINITIONS

The following terms, wherever used in the Contract Documents, as defined herein, shall have the meanings set forth below or in the Section enumerated below next to each term:

- (a) Agreement - as defined in Section 2.2(a).
- (b) Agreement Termination Date - as defined in Section 3.1(a).
- (c) Architect - [include Name, Address, etc., as applicable].
- (d) Artist - [include Name, Address, etc., as applicable].
- (e) BPCA - as defined in the introductory clause of this Agreement. BPCA hereby designates [BPCA Person and Title], as the representative of BPCA for the purpose of acting on behalf

of BPCA whenever action is required to be taken hereunder by BPCA. Such designation may be revoked in writing at any time after notice given by BPCA to Contractor. In addition, such representative of BPCA shall have full power and authority to delegate in writing any or all of her responsibilities hereunder to any one or more persons after notice to Contractor.

- (f) Certificate of Substantial Completion - as defined in Section 8.6.
- (g) Change Order - as defined in Section 9.1(b).
- (h) Construction Manager - [include Name, Address, etc., as applicable].
- (i) Contract Documents - as defined in Section 2.2.
- (j) Contract Price - as defined in Article 4.
- (k) Contract Time - the duration of time during which Construction Manager schedules and coordinates the Work of Contractor pursuant to Section 7.2 hereof.
- (l) Contractor - as defined in the first Recital of this Agreement.
- (m) Drawings - Project drawings comprising part of Exhibit [x].
- (n) Engineer [include Name, Address, etc., as applicable].
- (o) Extra Work - any work in addition to the Work to be performed by Contractor pursuant to the Contract Documents.
- (p) Field Order - as defined in Section 9.3.
- (q) Final Acceptance - as defined in Section 8.7.
- (r) Final Requisition - as defined in Section 5.2.
- (s) Guarantor - as defined in Section 27.3.
- (t) Joint Venture - an entity created pursuant to a written agreement among two or more contractors pursuant to which each shares in the direction and performance of the Work and shares in a stated percentage of profits or losses.
- (u) Key Person/Personnel - as defined in Section 27.25.
- (v) Materialman - supplier of Materials.
- (w) Materials - all products, materials, fixtures, tools, equipment, apparatus, and furnishings intended to form a part of the Work.
- (x) Minority Business Enterprise or Minority Owned Business Enterprise or MBE - as defined in Article 26.

- (y) Minority or Minority Group Member - as defined in Article 26.
- (z) Notice to Proceed - a written directive from BPCA to Contractor signed by a duly authorized BPCA representative directing Contractor to begin performance of the Work set forth in this Agreement on a particular date.
- (aa) Payment Bond - as defined in Section 13.3.
- (bb) Performance Bond - as defined in Section 13.3.
- (cc) Preceding Covered Date - as defined in Section 5.5.
- (dd) Product Data - illustrations, standard schedules, performance charts, instructions, brochures, diagrams and other information furnished by Contractor to illustrate a Material, product or system for some portion of the Work.
- (ee) Progress Schedule for the Work - as defined in Section 3.1(a).
- (ff) Project - as defined in the third Recital of this Agreement.
- (gg) Purchase Order - as defined in Section 10.1(e).
- (hh) Requisitions - as defined in Section 5.2.
- (ii) Samples - physical examples which illustrate Materials or workmanship and establish standards by which the Work will be judged.
- (jj) Site - as defined in the third Recital of this Agreement.
- (kk) Specifications - the specifications comprising part of Exhibit [x].
- (ll) Subcontract - an agreement between the Contractor and a Subcontractor (as defined in subsection (mm) below) for work on the Site.
- (mm) Subcontractor - a person, firm, partnership or corporation under contract with Contractor.
- (nn) Term - as defined in Section 3.1(a).
- (oo) Trade Payment Breakdown - as defined in Section 5.3.
- (pp) Women's Business Enterprise or Women Owned Business Enterprise or WBE - as defined in Article 26.
- (qq) Work - as defined in Section 2.1.
- (rr) Work Completion Date - as defined in Section 3.1(a).

ARTICLE 2 - SCOPE OF WORK, MATERIALS AND LABOR

2.1 Definition of Work

Contractor shall perform and complete (and shall cause all Subcontractors to perform and complete) for BPCA the work more particularly described in Exhibit A (the “**Work**”) annexed hereto and made a part hereof, required by and in conformity with the Contract Documents in connection with the construction of the Project on the Site. All materials to be furnished and labor and work to be performed and completed by Contractor and/or Subcontractors as required in the Contract Documents and in conformity with all requirements applicable with respect thereto are herein collectively referred to as the “**Work.**”

2.2 Contract Documents

The “**Contract Documents**” shall consist of the following:

(a) This instrument (the “**Agreement**”), which includes, in addition to the text comprising Articles 1 through 27, the following:

- (1) EXHIBIT A - SCOPE OF WORK (as applicable)
- (2) EXHIBIT B – DRAWINGS (as applicable)
- (3) EXHIBIT C – SPECIFICATIONS (as applicable)
- (4) EXHIBIT D - MONTHLY UTILIZATION COMPLIANCE REPORTS (as applicable)
- (5) EXHIBIT E - PROMPT PAYMENT POLICY (as applicable)
- (6) EXHIBIT F - INCIDENT REPORT FORM (as applicable)

(b) The Payment and Performance Bonds (as defined in Section 13.3).

(c) Change Orders adopted pursuant to Article 9.

The Contract Documents form the contract between BPCA and Contractor. References in the Contract Documents to “the Contract”, “this Contract” or “the Construction Contract” shall be deemed to include all of the Contract Documents. References to “this Agreement” or “the Agreement” shall refer to this instrument (including the Exhibits attached hereto), which is one of the Contract Documents.

2.3 Intent of Contract Documents

(a) The intent of the Contract Documents is to include in the Work all labor and materials, insurance, tools, equipment, permits, licenses, taxes, approvals, transportation, surveys, testing, field engineering and other professional services (other than the services of BPCA’s Architect, Construction Manager, Engineers, and attorneys, and the inspection, survey and testing services of BPCA) and any other items required to execute and complete the Work satisfactorily and in accordance with the Contract Documents. Contractor shall perform and complete the Work in accordance with the true intent and meaning of the Contract Documents and shall perform all Work incident thereto or as is usually performed in connection therewith or as is reasonably inferable therefrom, it being the intention that all work usually performed by the trade covered by

this Agreement and necessary to produce the intended result be performed by Contractor whether or not specifically covered by the Contract Documents.

(b) The Contract Documents are complementary and what is called for by one shall be as binding as if called for by all.

(c) If any conflicts or ambiguities are found in or between the Drawings and Specifications, or among any of the Contract Documents, they shall be brought to the attention of Construction Manager immediately for resolution. Architect and Construction Manager will interpret the Contract Documents so as to secure in all cases the most substantial and complete performance of the Work as is most consistent with the needs and requirements of the Work. In the event that Architect and Construction Manager disagree as to the interpretation of the Contract Documents, such dispute shall be presented to BPCA, which shall have sole authority to resolve the dispute.

(d) Addenda to parts of the Contract Documents are for the purpose of varying, modifying, rescinding or adding to the affected portion of the Contract Documents. All addenda should be read together with the portions of the Contract Documents to which they pertain. Where an addendum modifies a portion of a paragraph or a Section, the remainder of the paragraph or Section shall remain in force unless otherwise stated in the addendum.

(e) Captions, headings, cover pages, tables of contents and footnote instructions contained in the Contract Documents are inserted only to facilitate reference and for convenience and in no way define, limit or describe the scope, intent or meaning of any provision of the Agreement.

(f) Words and abbreviations which have well-known technical or trade meanings are used in the Contract Documents in accordance with such recognized meanings.

(g) Drawings and Specifications are complementary. Anything shown in the Drawings and not mentioned in the Specifications, or mentioned in the Specifications and not shown in the Drawings, shall have the same effect as if shown or mentioned in both.

(h) A typical or representative detail indicated on the Drawings shall constitute the standard for workmanship and Materials throughout corresponding parts of the Work. Where necessary, and where reasonably inferable from the Drawings or Specifications, Contractor shall adapt such representative detail for application to such corresponding parts of the Work. The details of such adaptation shall be subject to prior approval by Architect. Repetitive features shown in outline on the Drawings shall be in exact accordance with corresponding features completely shown.

(i) The layout of mechanical and electrical systems, equipment, fixtures, piping, ductwork, conduit, specialty items, and accessories indicated on the Drawings is diagrammatic, and all variations in alignment, elevation, and detail required to avoid interferences and satisfy Architectural and structural limitations are not necessarily shown. Actual layout of the Work shall be carried out without affecting the architectural and structural integrity and limitations of the Work and shall be performed in such sequence and manner as to avoid conflicts, provide clear access to all control points, including valves, strainers, control devices, and specialty items of

every nature related to such systems and equipment, obtain maximum headroom, and provide adequate clearances as required for operation and maintenance.

2.4 Completion of Drawings and Specifications

Contractor acknowledges that there are items of work which are not drawn or specified with complete detail in the Drawings and Specifications but which are required for the completion of the Work. Any such item, when identified as part of the reasonable development of the Work, shall be drawn or specified by Architect in consultation with Contractor, in a manner consistent with contemplated kind and quality and customary standards. When such drawing or specification is approved by BPCA, the drawing or specification so approved shall thereupon be part of the Contract Documents and the item of work shall be performed by Contractor as part of the Work without further action or order of Construction Manager or BPCA and without any increase in the Contract Price (as hereinafter defined) as if such drawing and/or specification were originally included in the Contract Documents.

2.5 Title to Materials

Title to all Materials shall immediately vest in BPCA upon payment in respect of such Materials, whether or not then incorporated or installed into the Project. The Materials shall then become the sole property of BPCA subject to the right of BPCA, Construction Manager or Architect to reject same for failure to conform to the standards of any or all of the Contract Documents. Title to all Work and Materials shall be in BPCA, free and clear of all liens, claims, security interests or encumbrances. Contractor warrants that no Work or Materials shall be fabricated or delivered to the Site by Contractor or any Subcontractor or Materialman subject to any security interest, lien or similar encumbrance.

2.6 Contractor's Obligations

(a) Contractor shall in a good and workmanlike manner perform all the Work required by this Agreement in accordance with the best practice of Contractor's trade within the time specified herein. Contractor shall supervise and direct the Work using its best skill and attention. Contractor shall be solely responsible for all construction means, methods, techniques, sequences and procedures within the scope of Contractor's Work.

(b) Contractor shall furnish, erect, maintain, and remove such construction plant and such temporary Work as may be required for the performance of the Work. Contractor shall be responsible for the safety, efficiency and adequacy of Contractor's plant, appliances and methods, and for damage that may result from failure or improper construction, maintenance or operation of such plant, appliances and methods. Contractor shall comply with all terms of the Contract Documents, and shall do, carry on and complete the entire Work under the direction of and to the satisfaction of BPCA.

(c) Contractor shall provide all equipment, tools and materials and whatever else may be required for proper performance of the Work unless stated otherwise in the Contract Documents.

(d) Contractor shall deliver all Materials at such times and in such quantities as will insure the speedy and uninterrupted progress of the Work. All Materials shall be delivered to the Site in proper order and quantity and shall be stored at the Site, if storage space is available in Construction Manager's opinion, in such places as Construction Manager shall direct; provided, that no delivery of Materials shall be made to the Site without prior approval by Construction Manager. Contractor has been advised and is aware that the Project is located in a congested metropolitan area, and there may not be sufficient space to store Materials on Site. If storage space is unavailable on Site, Contractor shall make arrangements to store Materials off Site at Contractor's own cost. Contractor shall not be entitled to additional compensation for moving Materials from one storage area to another, whether such storage areas are on or off Site. No Materials shall be removed from the Site without the consent of Construction Manager. Contractor shall handle and take care of all Materials used in performance of the Work whether furnished by Contractor or BPCA, as the same are delivered to the Site or to any applicable offsite storage location and shall be solely responsible for the security and condition of the same. After final completion and acceptance of the Work, or sooner if requested by Construction Manager, Contractor shall remove all surplus Materials and scaffolding furnished by it which have not been incorporated in the Work.

(e) Contractor shall follow and perform the Work in accordance with the Contract Documents as interpreted by Architect, Construction Manager, and BPCA.

(f) Unless otherwise provided in the Contract Documents, Contractor shall secure and pay for all permits and governmental fees, licenses and inspections necessary for the proper execution and completion of the Work. Contractor shall give all notices and comply with all laws, ordinances, rules, regulations and lawful orders of any public authority bearing on the performance of the Work. If Contractor observes that any of the Contract Documents are at variance with any applicable laws in any respect, Contractor shall promptly notify Architect and Construction Manager in writing, and any necessary changes shall be accomplished by appropriate modification. If Contractor performs any Work knowing it to be contrary to such laws, ordinances, rules and regulations, and without such notice to Architect and Construction Manager, Contractor shall assume full responsibility therefor and shall bear all costs attributable thereto.

(g) Contractor shall be responsible for collecting all paper, cartons and other debris caused by its Work or personnel, placing the same in a location designated by Construction Manager and keeping the portion of the Site upon which Contractor is performing the Work free from all debris.

(h) Contractor shall attend meetings as directed by BPCA or Construction Manager.

2.7 *"Or Equal" Clause*

(a) The Materials of manufacturers referred to in the Specifications and on the Drawings are intended to establish the standard of quality and design required by Architect; however, Materials of manufacturers, other than those specified, may be used if equivalent and approved by Architect, Construction Manager and BPCA.

(b) It is deemed that the term "or approved equal" is included after all Materials

referred to in the Specifications or on the Drawings.

(c) Architect will initially judge the equivalency of proposed substitute Materials. Architect will make written recommendation of acceptance or rejection to Construction Manager and/or BPCA. Construction Manager and/or BPCA will then authorize Architect to issue to Contractor written approval or rejection of the substitution.

(d) If Contractor desires to use a substitute item, Contractor shall make application to Architect in writing in sufficient time (with regard to the progress of the Work, the period of delivery of the goods concerned and adequate time for Architect's review) stating and fully identifying the proposed substitute, cost changes (if any), and submitting substantiating data, samples, brochures of the item proposed. It is Contractor's responsibility to provide at its sole expense sufficient evidence by tests or other means to support any request for approval of substitutions.

(e) Prior to proposing any substitute item, Contractor shall satisfy itself that the item Contractor proposes is, in fact, equal to that specified and had been used satisfactorily in similar applications to the application proposed for the Work, for at least three years, that it will fit into the space allocated and within the load allocated for the same, that it affords comparable ease of operations, maintenance and service, that its appearance, longevity and suitability for the climate and use are comparable to that specified, and that the substitution requires no change in dimension or design of any other Work of Contractor, of any other contractor or in the time required for the performance thereof.

(f) The burden of proof that a proposed substitution is equal to a specified item shall be upon Contractor, who shall support its request with sufficient test data and other means to permit Architect to make a fair and equitable decision on the merits of the proposal. Any item by the manufacturer other than those cited in the Contract Documents, or of brand name or model number or of generic species other than those cited in the Contract Documents, will be considered a substitution.

(g) Acceptance of substitutions shall not relieve Contractor from responsibility for compliance with all the requirements of the Contract Documents. If, notwithstanding the provisions of subsection (e) above, changes in other parts of the Work or the work of other contractors are required by its substitutions, Contractor shall be responsible for the costs of any such changes including the cost of all design and redesign services related thereto incurred by the Architect and its Contractors.

(h) The Contract Time shall not be extended by any circumstances resulting from a proposed substitution, nor shall Contractor be entitled to any compensation for any delay caused thereby or related thereto.

2.8 *Quality and Labeling*

All Materials furnished shall be new and the quality thereof shall be in accordance with the Contract Documents. When Materials are specified to conform to a given standard, the Materials delivered to the Site shall bear manufacturer's labels stating that the Materials meet such standard. The above requirements shall not restrict or affect BPCA's right to test Materials as provided in

this Agreement.

ARTICLE 3 - COMMENCEMENT AND COMPLETION OF THE WORK

3.1 Commencement, Completion and Progress Schedule

(a) Contractor shall prepare and submit a progress schedule for the Work (“**Progress Schedule for the Work**”) and agrees to be bound by and comply with the Work Completion Date and the Progress Schedule for the Project (as the Progress Schedule for the Project shall be updated pursuant to subsection (b)) and waives any right to charge or claim damages or any increased cost, charges or expenses against BPCA, Construction Manager, or Architect, for delays or disruptions from any cause whatsoever. Contractor’s sole remedy as against BPCA, Construction Manager, or Architect for any delays or disruptions shall be as provided in Section 3.4 hereof. Notwithstanding the foregoing, the Work shall be completed by no later than [date] (the “**Work Completion Date**”) with time being of the essence in respect of said Work Completion Date, as more fully set forth in subsection (h) below; this Agreement shall terminate by [date] (the “**Agreement Termination Date**”) (the period between the date of commencement of the Work and the Agreement Termination Date, the “**Term**”).

(b) The Progress Schedule for the Work shall be formatted in a detailed precedence-style critical path method, or such other format satisfactory to BPCA and Construction Manager and shall also (a) provide a graphic representation of all activities and events including float values that will affect the critical path of the Work, (b) incorporate and coordinate all pertinent information involving each phase of Work, and (c) identify dates that are critical to ensuring the timely and orderly completion of the work in accordance with the requirements of the Contract Documents, including the dates for Substantial Completion of each respective phase of the Work. The Progress Schedule for the Work shall be updated weekly, or at any other time at the request of Construction Manager or BPCA, and submitted to Construction Manager and BPCA for review and approval. Failure to submit any requested update shall constitute a material breach of this Agreement. The Contractor shall promptly give written notice of any actual or potential delays to BPCA and Construction Manager. After submission of the Progress Schedule for the Work, Construction Manager shall coordinate the Progress Schedule for the Work with the Progress Schedule for the Project. The Progress Schedule for the Work may be revised by Construction Manager from time to time.

(c) Contractor shall commence the Work upon receipt of a written notice to proceed signed by BPCA (the “**Notice to Proceed**”), and shall prosecute the Work diligently and in accordance with the time and place requirements of the Project as determined and directed by Construction Manager, by using such means and methods of construction as will assure that the Work will be performed hereunder in accordance with the Contract Documents and Progress Schedule for the Work, and to the satisfaction of BPCA, Architect, and Construction Manager.

(d) If, in the opinion of Construction Manager, Contractor falls behind the Progress Schedule for the Project then in effect, Contractor shall take whatever steps may be necessary to improve its progress and shall, if requested by Construction Manager, submit operational plans to demonstrate the manner in which the lost time may be regained. It is the responsibility of Contractor to maintain its schedule so as not to delay the progress of the Project or the schedules

of other contractors. If Contractor delays the progress of its Work or the work of other contractors, it shall be the responsibility of Contractor to increase the number of workers, the number of shifts, the days of Work and/or, to the extent permitted by law, to institute or increase overtime operations, all without additional cost to BPCA, in order to regain any time lost and maintain the Progress Schedule for the Project then in effect as established by Construction Manager.

(e) If Contractor shall fail to complete the Work by the Work Completion Date, or within the time to which such completion may have been extended, BPCA may, at its option, withhold from any sums otherwise due and owing to Contractor hereunder, so much of the balance thereof as BPCA shall deem necessary to secure it against any costs, expenses, or damages which may be incurred by BPCA as a result of said failure, but any such withholding shall not be deemed to be a waiver of any rights hereunder, and Contractor shall be liable to and shall indemnify and hold BPCA harmless from any and all cost, expense or damage incurred by BPCA by reason of such failure.

[(f) If Contractor shall neglect, fail or refuse to complete the Work on or before the Work Completion Date or any changes thereto in accordance with, or upon the expiration of, any proper extension granted by BPCA, Contractor agrees to pay to BPCA (\$\$\$\$\$), not as a penalty, **but as liquidated** damages for loss of beneficial use of the Project, for each and every calendar day that the Contractor is in default. Default shall include abandonment of the Work by Contractor.] **[delete if no liquidated damages]**

(g) [Said amount of liquidated damages is agreed upon by and between Contractor and BPCA because of the impracticability and extreme difficulty of fixing and ascertaining the actual damages which BPCA would sustain for loss of beneficial use of the Project in the event of delay in completion, and said amount is agreed to be the amount of damages sustained by BPCA and said amount may be retained from time to time by BPCA. The foregoing liquidated damages are intended to compensate BPCA only for the loss of beneficial use of the Project. In addition,] **[delete if no liquidated damages]** Contractor shall be liable to BPCA, to the fullest extent permitted by law, for whatever actual damages (other than actual loss of beneficial use) BPCA may incur as a result of any actions or inactions of Contractor or its Subcontractors including, without limitation, interest expense and carrying costs, liabilities to other Contractors working on the Project or other third parties, job extension costs, and other losses incurred by BPCA. The provisions of this paragraph are exclusive to BPCA, and shall not accrue to other contractors or third parties.

(h) It is further agreed that time is of the essence for each and every portion of the Work. In any instance in which additional time is allowed for the completion of any Work, the new time of completion established by said extension shall be of the essence. Contractor shall not be charged with [liquidated damages or] **[delete if no liquidated damages]** any excess cost if BPCA determines that Contractor is without fault and that the delay in completion of the Work is due to:

- (1) any preference, priority or allocation order duly issued by the Government of the United States or the State of New York;
- (2) an unanticipated cause beyond the control and without the fault of, or

negligence of Contractor, and approved by BPCA, including, but not limited to, acts of God or of public enemy, fires, epidemics, quarantine, strikes, freight embargoes and unusually severe weather; and

(3) any delays of Subcontractors or Materialmen occasioned by any of the causes specified in subsections 1 and 2 of this paragraph.

(i) Notwithstanding the foregoing, and whether or not, at any given time, a Progress Schedule, or update thereto (as appropriate) has been submitted, the Work shall be completed by the Work Completion Date.

(j) Notwithstanding anything to the contrary, a schedule submitted by Contractor showing a time of completion earlier than that specified in the Contract shall not entitle Contractor to any additional compensation in the event the earlier time of completion is not realized.

3.2 Coordination with Other Contractors

Contractor shall coordinate the Work to be performed hereunder with the work of other contractors performing work for the Project in such manner as Construction Manager shall direct. Contractor shall indemnify and hold BPCA, Construction Manager, and Architect harmless from any and all claims or judgments for damages, costs and expenses to which BPCA, Construction Manager or Architect may be subjected or which they may suffer or incur by reason of Contractor's failure to promptly comply with Construction Manager's directions. If Contractor notifies Construction Manager in writing that another contractor is failing to coordinate its work with the Work to be performed hereunder, Construction Manager shall promptly investigate the charge. If Construction Manager finds that charge to be true, it shall promptly issue such direction to the other contractor with respect thereto as the situation may require. BPCA, Construction Manager and Architect shall not, however, be liable for any damages suffered by Contractor by reason of the other contractor's failure to promptly comply with the directions so issued by Construction Manager or by reason of another contractor's default in performance. Should Contractor sustain any damage through any act or omission of any other contractor, Contractor shall have no claim against BPCA, Construction Manager or Architect for such damage but shall have a right to recover such damage from the other contractor, under a provision similar to a provision contained in the following sentence which is part of this Agreement and which has been or will be inserted in the contracts with the other contractors engaged in the Project.

Should any other contractor having or who shall hereafter have a contract with BPCA for the performance of work upon the Project sustain any damage through any act or omission of Contractor hereunder, Contractor shall reimburse such other contractor for all such damages and to indemnify and hold BPCA, Construction Manager and Architect harmless from all such claims. Any claim against a performance bond surety made by any contractor shall be subordinated to any claim of BPCA then existing or that may arise in the future against such other contractor or its performance bond surety.

3.3 Notice of Delay

Should Contractor be or anticipate being delayed or disrupted in performing the Work hereunder for any reason, including, without limitation, its financial condition or Contractor's

general nonpayment of its debts as such debts become due, it shall promptly and in no event more than three (3) days after the commencement of any condition that is causing or is threatening to cause such delay or disruption notify Construction Manager in writing of the effect of such condition upon the Progress Schedule for the Project, stating why and in what respects the condition is causing or is threatening to cause delay, provided, however, that notwithstanding the above, if such delay or disruption, or anticipated delay or disruption, should be the result of any change or anticipated change in Contractor's financial condition, Contractor shall notify Construction Manager forthwith of such cause or anticipated cause. Failure to strictly comply with this notice requirement shall be sufficient cause to deny Contractor a change in schedule and to require it to conform to the Progress Schedule for the Project then in effect established by Construction Manager.

3.4 Extension of Time

(a) An extension of time under the Progress Schedule for the Project then in effect may be granted by BPCA subject to the provisions hereof upon written application therefor by Contractor. An application for an extension of time under the Progress Schedule for the Project then in effect must set forth in detail the nature of each cause of delay in the performance of the Work, the date or dates upon which each cause of delay began and ended and the number of days delay attributable to each such cause. After the application is submitted, Contractor shall supply any other data that Construction Manager may request.

(b) Contractor shall be entitled to an extension of time under the Progress Schedule for the Project then in effect for delays in the performance of the Work, if caused:

(1) solely by unanticipated acts or omissions of BPCA, Construction Manager or Architect; or

(2) by the unanticipated acts or omissions of other contractors or unanticipated causes beyond the control and without the fault or negligence of Contractor including, but not limited to, acts of God, acts of public enemy, acts of any Government body, fires, floods, epidemics, quarantine restrictions, strikes, freight embargoes, unusually severe weather, or delays of Subcontractors or Materialmen arising from unforeseeable causes beyond the control and without the fault or negligence of both Contractor and such Subcontractors or Materialmen; provided, that Contractor shall have used its best efforts and diligently sought to have minimized any such period of delay, by taking whatever measures are necessary, including without limitation, if applicable, seeking alternate sources of Materials, other Subcontractors or other facilities in which to perform the required construction operations; and provided, further, that an application is made pursuant to the requirements of the immediately preceding paragraph.

ARTICLE 4 - CONTRACT PRICE

For the performance and completion of the Work, BPCA shall pay Contractor a lump sum amount of (\$\$\$\$), (such sum is herein sometimes referred to as the "**Contract Price**"), which amount shall include any monies earned by or paid to Contractor prior to the execution of this Agreement, provided, that if the Contract Price shall be expressly revised by a Change Order in accordance with Article 9 hereof, the Contract Price shall thereafter mean the Contract Price as so

revised. Contractor will submit appropriate Time Sheets in the form of Exhibit [x].

ARTICLE 5 - METHOD, SCHEDULE AND TERMS OF PAYMENTS

5.1 Partial Payment

(a) In accordance with Requisitions (as defined in Section 5.2) submitted and approved as provided below for Work performed in accordance with this Agreement, Contractor shall be entitled to partial payment on account of the Contract Price in an amount equal to the value, as determined in accordance with the Trade Payment Breakdown (as defined in Section 5.3), of the portions of the Work completed and acceptable to BPCA and Construction Manager for purposes of such payment, less a retainage equal to ten percent (10%) of the total amount of all prior partial payments. Partial payments shall constitute advances against the Contract Price until final payment is made and accepted. No partial payment made, nor approval of a portion of the Work given for purposes of making a partial payment, shall constitute an acceptance of any Work not in accordance with the Contract Documents.

(b) Upon completion of fifty percent of the Work, Contractor may make written application to BPCA requesting reduction of the retainage set forth in Section 5.1(a) hereof. Approval of such reduction of retainage and the percentage to which the retainage shall be reduced is in the sole discretion of BPCA. If BPCA approves a reduction of retainage as herein described, BPCA shall so notify Contractor in writing. Any reduction of retainage pursuant to this paragraph (b) shall not be deemed to be a waiver of retainage requirements for future partial payments.

5.2 Requisitions

Applications for partial payments (“**Requisitions**”) and application for final payment (“**Final Requisition**”) shall be in the form previously supplied by BPCA and shall be submitted by Contractor to Construction Manager or its designee in five original copies in the manner hereinafter provided for the approval of BPCA and Construction Manager. Each Requisition shall be supported by such data substantiating Contractor’s right to payment as BPCA and Construction Manager may require.

5.3 Trade Payment Breakdown

Prior to the submission of the first Requisition, Contractor shall present to Construction Manager for approval a trade payment breakdown (the “**Trade Payment Breakdown**”) of the various portions of the Work, aggregating the Contract Price, prepared in such form as specified by BPCA and supported by such data to substantiate its correctness as Construction Manager may require. After approval by BPCA and Construction Manager, the Trade Payment Breakdown shall not be changed or revised in any way without the written consent of Construction Manager. The Trade Payment Breakdown, when approved by Construction Manager, shall be used only as a basis for Requisitions and shall not be considered as a basis for reducing or increasing the Contract Price.

5.4 Payment for Stored Materials

If approved in advance of delivery by BPCA and Construction Manager, payments will be

made on account of 80% of the value of Materials that have not been incorporated in the Work to date, but delivered and suitably stored at the Site or at some other offsite location agreed upon in writing by BPCA and Construction Manager. Such payments shall be conditioned upon submission by Contractor of bills of sale or other supporting documentation satisfactory to BPCA and Construction Manager to establish BPCA's title to such Materials including applicable insurance and transportation to the Site for those Materials stored offsite. In the event that Contractor, with approval of BPCA, stores any Materials offsite, the conditions for payment of Material stored off-site shall include but not be limited to the following: (a) the Material shall be properly stored in a secured location approved by the BPCA and/or Construction Manager; (b) the Material will be covered under the BPCA's builder's risk policy subject to policy limits and restrictions; and (c) the Material may be inspected by the BPCA and /or Construction Manager to assure compliance with Contract Documents.

5.5 Receipts and Releases of Liens

With each Requisition, Contractor shall furnish its affidavit of payment and waiver of lien for Work done and Materials furnished through the date covered by the last preceding partial payment (the "**Preceding Covered Date**") and shall furnish its affidavit certifying that all Subcontractors and Materialmen have been paid for Work performed and Materials furnished through the Preceding Covered Date except for any permitted retainage. BPCA may also require Contractor to attach to each Requisition (i) affidavits of payment and waivers of lien from all Subcontractors and Materialmen dealing directly or indirectly with Contractor for Work performed and Materials furnished through the Preceding Covered Date and/or (ii) the consent of the surety issuing the Payment Bond to such payment. BPCA may require Contractor to execute a waiver of lien at the time payment is made for a Requisition for all Work performed through the date of the Requisition in respect of which payment is being made.

In addition to the documents required to be furnished by the preceding paragraph, with the Final Requisition, Contractor shall furnish (y) its affidavit that there are no liens, claims or demands by, and that there is no indebtedness to, Subcontractors, Materialmen, laborers, other employees or third persons for which BPCA, Construction Manager, or Architect might in any way be responsible and (z) releases from all Subcontractors and Materialmen dealing directly or indirectly with Contractor. Should any such Subcontractor or Materialman fail or refuse to furnish such release, Contractor may be required to furnish a bond satisfactory to BPCA to indemnify it against any such lien, claim or demand. If any such lien, claim or demand remains unsatisfied after all payments are made to Contractor, Contractor shall refund to BPCA all monies that BPCA may be compelled to pay in discharging such lien, claim or demand including all costs, expenses and attorneys' fees which BPCA may incur in connection therewith.

5.6 Time of Payment

Requisitions shall be submitted by Contractor to BPCA and Construction Manager by the seventh day of each calendar month for Work completed up to the last calendar day of the previous month or other day approved by BPCA, and payment shall be made (pursuant to BPCA's Prompt Payment Policy, a copy of which is attached hereto and made part hereof as Exhibit E) on or about twenty days after BPCA receives the Requisition together with the documents required pursuant to Sections 5.2 and 5.5 hereof. Contractor shall be entitled to payment only in the amount approved

by BPCA and Construction Manager with respect to such Requisitions, each of which must be signed by BPCA and Construction Manager before payment is made. The value of any Work included in a Requisition for partial payment which is found unacceptable by BPCA or Construction Manager may be deducted from that or any subsequent Requisition.

5.7 Reduction of Retainage

Upon the issuance of a Certificate of Substantial Completion, as defined in Section 8.6, Contractor shall submit a Requisition in an amount equal to the Contract Price less five percent (5%) of the total contract amount (including all approved Change Orders and pending Change Order proposals), and less the total amount of all prior payments. Upon approval of the same by BPCA, BPCA shall pay to Contractor the amount approved less any amount which BPCA is entitled to withhold hereunder.

5.8 Final Payment

(a) The final balance due Contractor under this Agreement shall be payable to Contractor by BPCA, as final payment hereunder, within thirty days after all of the following have taken place:

- (1) Contractor's Final Requisition has been submitted by Contractor and approved by BPCA and Construction Manager;
- (2) the affidavit provided for in Section 5.5 hereof has been submitted by Contractor, and any other documents or actions expressly specified in the Contract Documents as preconditions to final payment have been submitted or completed; and
- (3) any inspections or approvals with respect to any of the Work that BPCA deems legally required or appropriate by governmental authorities or by the applicable Board of Fire Underwriters have been performed or obtained.

(b) The acceptance of final payment shall constitute a waiver of all claims by Contractor.

5.9 Release and Consent of Surety

Notwithstanding any other provision of this Agreement, before final payment pursuant to Section 5.8 shall become due pursuant hereto or before reduction of retainage, Contractor shall submit to BPCA a consent of surety to final payment or reduction of retainage in form and substance acceptable to BPCA.

5.10 BPCA's Right to Audit and Inspect Records

Contractor shall maintain and shall keep for a period of at least six years after the date of Final Acceptance of the Work, pursuant to Section 8.7, all records and other data relating to the Work. BPCA or its designee shall have the right to inspect and audit all records and other data of Contractor relating to the Work at any time and from time to time until the end of such six year

period. Contractor shall promptly respond to any inquiries of BPCA or any representative of BPCA arising out of any such inspection or audit.

5.11 Withholding of Payments

(a) BPCA may withhold payment or, because of subsequently discovered evidence, may nullify the whole or any part of any previously approved Requisition to such extent as may, in the judgment of BPCA, be necessary:

- (1) to assure payment of just claims or liens of any persons supplying labor or Materials for the Work;
- (2) to protect BPCA from loss due to defective Work or to reimburse BPCA, Construction Manager and Architect for fines on account of non-compliance with applicable laws, rules and regulations, including rules promulgated by the Office of Safety & Health Administration;
- (3) to protect BPCA from loss due to death or injury to persons or damage to the Work or property of BPCA, other contractors or others caused by the act or neglect of the Contractor;
- (4) in the event that there is reasonable evidence that the Work will not be completed for the unpaid balance of the Contract Price;
- (5) in the event that there is reasonable evidence that the Work will not be completed within the time provided; or
- (6) in the event that Contractor persistently fails to perform the Work in accordance with the Contract Documents.

In any of such events, BPCA shall have the right to apply any such amounts so withheld in such manner as BPCA may deem proper to satisfy such claims, to secure such protection, to complete the Work or to compensate BPCA for any loss suffered by reason of Contractor's delay. Such application shall be deemed payment for the account of Contractor. In the event that BPCA gives Contractor notice that it intends to make such application, Contractor shall be estopped from disputing liability or the amount of liability unless, within three days after receipt of such notice, it indicates to BPCA in writing that it is not liable or that the amount of its liability is different from that set forth in the notice.

(b) The provisions of this Section 5.11 are solely for the benefit of BPCA, and any action or non-action by BPCA shall not give rise to any liability on the part of BPCA. Failure to so act shall not be deemed a waiver of any present or future claims of BPCA.

ARTICLE 6 – CONTRACTOR

6.1 Superintendence by Contractor, Discipline and Employee Skills

Contractor shall provide a competent construction superintendent to be in charge of the

Work. The construction superintendent shall devote full time to the Work, shall be present at the Site during the time the Work is required to be performed and shall have full authority to accept instructions, make decisions and act for Contractor at all times. If at any time the construction superintendent is not satisfactory to BPCA or Construction Manager, Contractor shall, if requested by BPCA, replace such superintendent with another satisfactory to BPCA. Contractor shall enforce strict discipline and good order at all times among Contractor's employees and all Subcontractors. Contractor shall not engage any employee not skilled in the task assigned.

6.2 *Representations and Warranties*

Contractor represents and warrants that:

(a) Contractor is financially solvent and is experienced in, and competent to perform the Work and has the staff, manpower, equipment, Subcontractor, and suppliers available to complete the Work within the time specified in this Agreement for the Contract Price;

(b) Contractor is familiar with all Federal, State or other laws, ordinances, orders, rules and regulations, which may in any way affect the Work;

(c) any temporary and permanent Work required by this Agreement can be satisfactorily constructed, and such construction will not injure any person or damage any property; and

(d) Contractor has carefully examined the Contract Documents and the Site and, from Contractor's own investigations, is satisfied as to the nature and location of the Work, the character, quality and quantity of surface and subsurface materials likely to be encountered, the character of equipment and other facilities needed for the performance of the Work, the general and local conditions, and all other conditions or items that may affect the Work. Prior to submitting its bid for performance of the Work, Contractor notified BPCA or Construction Manager in writing of any discrepancies or errors in the Contract Documents.

6.3 *Verifying Dimensions and Site Conditions*

Before proceeding with the Work, Contractor will check all previous and surrounding work and determine the correctness of the same; failure on its part to detect or report discrepancies will relieve BPCA of liability from any and all claims to recover cost, expense, loss or damage resulting therefrom. Contractor shall take, determine, investigate and verify all field measurements, dimensions, field construction criteria and Site conditions for the performance of the Work and shall check and coordinate the information contained in the Contract Documents and the boring logs which shall be available for inspection with the requirements of the Work. Contractor shall be responsible for determining the exact location of and to verify the spatial relationships of all Work. If any conflicts or discrepancies are found in the Contract Documents or if Contractor has any questions concerning the foregoing, it shall immediately notify Construction Manager and shall thereafter perform the Work in accordance with the directions of Construction Manager.

6.4 *Copies of Contract Documents for Contractor*

BPCA shall furnish to Contractor, without charge, two sets of the Contract Documents. Any sets in excess of the number mentioned above may be furnished to Contractor at the cost of reproduction and mailing.

6.5 *Meetings*

Contractor shall attend all meetings as directed by BPCA or Construction Manager, including meetings set forth in Section 26.3, and shall be represented at such meetings by a person having knowledge of the Work and authorized to act for Contractor at all times. If at any time such person is not satisfactory to BPCA or Construction Manager, Contractor shall, if requested by BPCA, be represented by another person satisfactory to BPCA, having knowledge of the Work and authorized to act for Contractor at all times.

6.6 *Related Work*

Contractor shall examine the Contract Documents for related work to ascertain the relationship of such work to the Work under the Contract Documents.

6.7 *Surveys and Layout*

Unless otherwise expressly provided in this Agreement, BPCA shall furnish Contractor survey points necessary for the Work, but Contractor shall lay out the Work.

6.8 *Reports and Access*

Contractor shall furnish BPCA and Construction Manager with daily and monthly manpower reports on forms provided by BPCA or Construction Manager and such other reports as may be required by BPCA or Construction Manager. BPCA, Construction Manager and Architect shall have full and free access to the shops, plants and factories of Contractor, any Materialmen and Subcontractors to inform themselves as to the progress of the Work.

6.9 *Financial Information*

During the Term, Contractor agrees to notify BPCA forthwith in writing of any event which has caused or is reasonably anticipated to cause a material adverse change in Contractor's business or financial condition from that shown in the then most recent financial statements furnished by Contractor to BPCA. Contractor has furnished to BPCA financial statements regarding the period from [date] to [date]. Contractor agrees to furnish to BPCA, at BPCA's request from time to time hereafter, quarterly, or annual financial statements (which shall be audited, if such is the practice of Contractor for financial statements covering the applicable period) and such additional information as BPCA shall deem necessary or desirable to satisfy itself of Contractor's continuing ability to complete the Work.

ARTICLE 7 - CONTRACT ADMINISTRATION

7.1 *Architect's Responsibilities and Functions*

Contractor acknowledges that the role of Architect with respect to the Work shall be as specified in this Agreement. Contractor will comply with the instructions of Architect pursuant hereto.

Architect's duties and services shall in no way supersede or dilute Contractor's obligation to perform and complete the Work in conformity with the Contract Documents.

7.2 Construction Manager's Responsibilities and Functions

(a) Construction Manager shall coordinate and schedule construction to insure that the completion of the Project is on schedule and that the Project is well constructed in accordance with the Contract Documents. Contractor acknowledges that the role of Construction Manager with respect to the Work shall be as specified in this Agreement. Contractor hereby agrees to comply with the directions and instructions of Construction Manager.

(b) Construction Manager shall call for meetings of Contractor, other contractors, Subcontractors and Materialmen as necessary for the proper coordination of the Work. Such meetings shall be held at the Site on regular working days, during regular working hours, unless otherwise directed by BPCA. Attendance shall be mandatory for all parties notified to attend.

7.3 Scope of Responsibility of Architect and Construction Manager

In no event shall any act or omission on the part of the Construction Manager or Architect relieve Contractor of its obligation to perform the Work in full compliance with the Contract Documents. Neither Architect nor Construction Manager will be responsible for construction means, methods, techniques, sequences or procedures, or for safety precautions and programs in connection with the Work, and neither will be responsible for Contractor's failure to carry out the Work in accordance with the Contract Documents or the failure to fulfill any of the requirements of this Agreement.

ARTICLE 8 - INSPECTION AND ACCEPTANCE

8.1 Access to the Work

BPCA, Construction Manager, Architect or their authorized representatives shall at all times have access to and the right to observe the Work and all facilities where the Work or any part thereof is being fabricated or stored, and Contractor shall provide proper facilities for such access and observation.

8.2 Notice of Required Inspections and Tests

If the Contract Documents, or any laws, rules, ordinances or regulations, require that any Work be inspected or tested, Contractor shall give BPCA, Construction Manager and Architect at least five days prior written notice of readiness of the Work for inspection or testing and the date fixed for such inspection or testing.

8.3 Additional Inspections and Tests

(a) Whenever, in the opinion of BPCA, Construction Manager or Architect, it is desirable to require inspection or testing of the Work or its individual components in addition to any such testing that may be originally included in the Work, they shall have authority to do so whether or not such Work be then fabricated, installed, covered or completed. If such inspection or testing reveals a failure of the Work to comply (1) with the requirements of the Contract Documents, or (2) with respect to the performance of the Work, with laws, ordinances, rules, regulations or orders of any public authority having jurisdiction, Contractor shall bear all costs thereof, including Architect's and Construction Manager's additional services made necessary by such failure; otherwise BPCA shall bear such costs, and an appropriate Change Order shall be issued.

(b) In the event that any item of the Work fails inspection or testing, BPCA, Architect or Construction Manager may require inspection or testing of any or all of the other items of the Work at Contractor's cost and expense.

8.4 Uncovering of Work

(a) If any Work shall be covered or concealed contrary to the request of BPCA, Architect or Construction Manager, such Work shall, if required by BPCA, Architect or Construction Manager, be uncovered by examination, inspection or testing. Any examination, testing or inspection shall not relieve Contractor of the responsibility to maintain quality control over the Work. If any test results are below specified minimums, BPCA may order additional testing. The cost of such additional examination, inspection or testing, any additional professional services required, and any other expenses incurred by BPCA as a result of such examination, inspection or testing shall be borne by Contractor.

(b) In the event that a typical detail fails inspection or testing, BPCA, Architect or Construction Manager may require inspection or testing of any or all of other such typical details at Contractor's cost and expense.

8.5 Correction of Work

Any Work not approved by BPCA, Architect and Construction Manager shall immediately be reconstructed, made good, replaced or corrected by Contractor including all Work of other contractors destroyed or damaged by such removal or replacement. Rejected material shall be removed immediately from the Site. Acceptance of Materials and workmanship by BPCA shall not relieve Contractor from Contractor's obligation to replace all Work which is not in full compliance with the Contract Documents.

8.6 Certificate of Substantial Completion

Upon their receipt of written notice from Contractor stating that in Contractor's estimation the Work has been substantially performed in conformity with the Contract Documents, Architect and/or Construction Manager shall perform an inspection for the purposes of determining whether the Work has been so performed, commencing such inspection within ten (10) days of receipt of such notice and completing it with all due diligence. When Architect and/or Construction Manager find upon inspection that, to the best of their knowledge and belief, the Work is so performed, they shall prepare and deliver to BPCA for delivery to Contractor a certificate specifying the date of

substantial completion of the Work for purposes of this Agreement (“**Certificate of Substantial Completion**”) and a punch list of items of Work remaining to be completed.

The delivery of a Certificate of Substantial Completion shall not terminate or alter Contractor’s obligation under this Agreement to complete the Work as expeditiously as practicable in conformity with the Contract Documents and to fulfill all terms and conditions of this Agreement.

8.7 Completion of Work and Acceptance

Upon their receipt of written notice from Contractor stating its belief that the Work has been fully performed in conformity with the Contract Documents, and confirming that Contractor has completed any items of Work previously noted to it by Architect and Construction Manager as not having been acceptably completed in any punch list or otherwise, Architect and Construction Manager shall perform an inspection for purposes of determining whether the Work has been so performed. Architect and Construction Manager shall commence such inspection within ten (10) days of receipt of such notice and shall pursue and complete it with all due diligence. When BPCA and Construction Manager find upon inspection that, to the best of their knowledge and belief, the Work has been so performed, they shall prepare a certificate of final completion, and, upon delivery by BPCA to Contractor of said certificate, the Work shall be deemed to be finally accepted by BPCA (such delivery of the certificate of final completion to Contractor is hereinafter referred to as “**Final Acceptance**”).

Final Acceptance shall not terminate or alter Contractor’s obligation under this Agreement to complete the Work in conformity with the Contract Documents and to fulfill all terms and conditions of this Agreement.

ARTICLE 9 - CHANGES IN THE WORK

9.1 Change Orders

(a) BPCA may, at any time, in any quantity or amount, without notice to the sureties and without invalidating or abandoning this Agreement, order Extra Work. Notwithstanding the terms of subsection 3.1(a) hereof, BPCA may, but shall be under no obligation to, change the manner, sequence or method of performance of the Work or direct acceleration of the Work and Contractor shall, therefor, be entitled to a Change Order (as defined in Section 9.1(b)) provided that such change or acceleration was not ordered to maintain the Progress Schedule for the Project, the Progress Schedule for the Work or to coordinate the Work with the work of other contractors. Contractor shall be obligated to perform changed Work promptly in conformity with any Change Order or Field Order issued in accordance herewith and may not suspend or otherwise refuse to perform the Work contained therein or any other aspect of the Work required under this Agreement because a Change Order has yet to be fully executed.

(b) “**Change Order**” shall mean a written order issued by BPCA to Contractor after execution of this Agreement, authorizing or requiring:

- (1) Extra Work,

- (2) items that were erroneously deleted or omitted from the Work,
- (3) items that were included in the Work but were subsequently deleted,
- (4) an extension or decrease of time to complete Work,
- (5) an increase or reduction in the payment to Contractor, or
- (6) any other change in the Contract Documents or in the sequence of performing or phasing of the Work.

(c) All Change Orders shall be prepared, signed and issued by Construction Manager at the instruction of BPCA, and to be valid, must be countersigned by BPCA and Contractor.

9.2 Change in Contract Price and Time

(a) The Contract Price will not be revised due to any change of the Work except as and to the extent expressly provided in the Change Orders. The amount by which the Contract Price is to be increased or decreased by any Change Order shall be determined by BPCA and Construction Manager by one or more of the following methods:

- (1) accepting an amount agreed upon by BPCA and Contractor;
- (2) applying the applicable unit prices and alternates where the Work involved is covered by unit prices in this Agreement;
- (3) receiving from Contractor a detailed breakdown satisfactory to BPCA and Construction Manager, including actual time slips and invoices, itemizing the direct cost of labor and Materials to perform the changed Work and adding thereto fifteen percent (15%) to cover profit and all indirect and overhead costs, except that where the changed Work is performed by a Subcontractor or Materialman, the direct cost of labor and Materials to perform the changed Work plus fifteen percent (15%) for profit and all indirect and overhead costs to Subcontractor or Materialman and an additional sum for profit and all indirect and overhead costs of Contractor equal to ten percent (10%) of the first \$100,000, five percent (5%) of the second \$100,000 and three percent (3%) of any cost in excess of \$200,000 to Contractor. No allowance shall be paid on the premium portion of overtime pay. Where the changed Work involves both an increase and a reduction in any contract Work, the above percentage override shall be applied only on the amount, if any, by which the cost of the increase exceeds the cost of the reduction.
- (4) receiving from Contractor a true copy of its bid work sheets to determine the contract price for the elimination of any contract Work. The amount of reduction shall not include the overhead or profit of Contractor for the eliminated Work. Should Contractor fail to furnish BPCA with such bid work sheets, then Construction Manager shall determine the amount of the reduction. The determination of Construction Manager shall be final and binding unless erroneously or fraudulently arrived at, or arbitrary and capricious;
- (5) adding to the Contract Price only the amount of the premium portion of overtime pay resulting from an acceleration of the Work; or

(6) adding to the Contract Price, the actual incremental labor and equipment costs incurred by the Contractor resulting from a change in the manner, sequence or method of performing the Work.

(b) The compensation specified in a Change Order shall constitute a release and full payment for the Extra Work covered thereby and for any delay and disruption cost or expense occasioned by reason of said change in the Work.

(c) No time extension shall be granted Contractor by reason of the issuance of any Change Order unless it is expressly stated therein.

9.3 *Field Orders*

Construction Manager shall have the authority to order minor changes in the Work by the issuance of written field orders (“**Field Orders**”), which may be issued without prior approval by BPCA. Field Orders must be countersigned by Contractor. Minor changes in the Work for purposes of this Section shall mean only changes that do not necessitate or warrant any revision in the Contract Price in excess of \$5,000 or affect the time of performance of Contractor’s Work, any change in the basic character or design of the Project, or deviation from design standards established for the Project. Except as otherwise provided in the preceding sentence relating to an increase in the Contract Price, no claim for an increase in the Contract Price may be based upon any Field Order. If Contractor, on receipt of a Field Order, claims that the change of Work involved necessitates a Change Order, it shall proceed in accordance with the Field Order under protest and notify BPCA immediately of its claim for additional compensation for Extra Work pursuant to Article 14.

9.4 *Changed Conditions*

(a) BPCA assumes no responsibility for the correctness of any boring or other subsurface information and makes no representation of any kind regarding subsurface conditions and test borings, reports, rock cores, foundation investigation and topographical maps which may be made available to Contractor.

(b) Contractor shall promptly, and before such conditions are disturbed, notify Construction Manager of: (1) subsurface or latent physical conditions differing materially from those indicated in the Contract Documents, or (2) unknown physical conditions of an unusual nature, differing materially from those ordinarily encountered and generally recognized as inherent in work of the character provided for in this Agreement. Construction Manager shall promptly investigate the conditions, and if it finds that such conditions do materially so differ and cause an increase or decrease in Contractor’s cost of, or the time required for, performance of any part of the Work under this Agreement, Contractor shall be paid in the manner provided for payment with respect to any Change Order and receive, if warranted, a time extension.

(c) No claim of Contractor under this clause shall be allowed unless Contractor has given the notice required in subsection (b) above.

ARTICLE 10 - SUBCONTRACTS AND PURCHASE ORDERS

10.1 Selection of Subcontractors and Materialmen and Approval of Subcontracts and Purchase Orders

(a) Contractor shall submit to Construction Manager, within 21 calendar days of the issuance of the Notice to Proceed, the names of all persons with whom it has contracted or intends to contract or hereafter contracts with respect to the Work.

(b) Except as specifically provided herein, Contractor shall not enter into any Subcontracts or issue any Purchase Orders (as hereinafter defined) to any Materialmen in connection with the performance of Contractor's obligations hereunder without the prior written consent of BPCA to the use of each such Subcontractor or Materialman, and to the agreement to be entered into between Contractor and any such Subcontractor or Materialman. Contractor shall inform BPCA in writing of any interest it may have in a proposed Subcontractor or Materialman. No such consent by BPCA, or employment, contract, or use by Contractor, shall relieve Contractor of any of its obligations hereunder nor may BPCA be held responsible in any way for the performance of a Subcontractor or Materialman to whom BPCA gave its consent.

(c) Contractor shall be responsible for the performance of the Work of any Subcontractors or Materialmen engaged, including the maintenance of schedules, coordination of their Work and resolutions of all differences between or among Contractor and any Subcontractors. It is expressly understood and agreed that any and all Subcontractors or Materialmen engaged by Contractor hereunder shall at all times be deemed engaged by Contractor and not by BPCA.

(d) Upon the request of BPCA, Contractor shall cause any Subcontractor or Materialman employed by the Contractor in connection with this Agreement to execute a copy of the Agreement wherein such Subcontractor or Materialman shall acknowledge that it has read and is fully familiar with the terms and provisions hereof and agrees to be bound thereby as such terms and provisions are or may be applicable to such Subcontractors or Materialmen.

(e) Contractor shall submit to BPCA promptly following execution, three copies of every revision, amendment, modification or cancellation executed or issued by Contractor with respect to any Subcontractor or Materialman. BPCA is not obligated to make payment on account of Work performed or Materials furnished by a Subcontractor or a Materialman under a Subcontract or contract for construction supplies or Materials (hereinafter "**Purchase Order(s)**") unless there shall have been filed with BPCA prior to the submission of a Requisition for each payment, three copies of such Subcontract or Purchase Order containing the provisions required by this Agreement to be contained therein, except as may otherwise be specified by BPCA with respect to Purchase Orders for minor purchases.

10.2 Access by BPCA and Others

Contractor shall include a provision in all Subcontracts and Purchase Orders stating that, to permit verification of Contractor's costs, BPCA shall have the right to have its representatives inspect and audit the books of account and records of the Subcontractor and Materialmen, including the right to make excerpts from such books and records. All payments by Contractor to a Subcontractor or Materialman shall be by check specifically indicating that payment is

attributable to this Agreement and identifying the invoice(s) for which payment is being made. Contractor shall include a provision in all Subcontracts and Purchase Orders that will enable representatives of the State of New York, Construction Manager and BPCA, as the case may be, to obtain access during working hours to the appropriate books of account and records of the Subcontractors or Materialmen relating to the Work to determine if there is compliance with the requirements of law or this Agreement.

10.3 Retainage

Contractor may provide for a retainage under any of its Subcontracts or Purchase Orders provided that where a Subcontract or Purchase Order provides for a retainage, the retainage shall be no greater in percentage than that provided for under Sections 5.1 or 5.7 hereof with respect to Contractor itself, unless otherwise approved in writing by BPCA. Contractor shall submit with each Requisition a statement setting forth the amounts of all retainage, if any, under its Subcontracts and Purchase Orders.

10.4 Miscellaneous

(a) Contractor shall be fully responsible for the work, acts and omissions of Subcontractors and Materialmen, and of persons either directly or indirectly employed by Subcontractors and Materialmen.

(b) Contractor's use of Subcontractors and Materialmen shall not diminish Contractor's obligation to complete the Work in accordance with the Contract Documents. Contractor shall control and coordinate the work of Subcontractors and Materialmen.

(c) Nothing contained in this Agreement shall create any contractual relationship between Subcontractors or Materialmen and BPCA, Construction Manager or Architect. Nothing in this Section shall obligate BPCA to pay or to see to the payment of any sums to any Subcontractor or Materialmen.

(d) Contractor shall include a provision in all Subcontracts and Purchase Orders exceeding \$50,000, requiring the Subcontractor or Materialman, if requested by BPCA, until the Subcontractor or Materialman finishes its portion of the Work, to deliver to Contractor unaudited and, if available, audited financial statements of the Subcontractor or Materialman similar to the obligation of Contractor under Section 6.8 and promptly upon receipt thereof Contractor shall deliver copies thereof to BPCA.

ARTICLE 11 - ASSIGNMENT

11.1 No Assignment of Duties

Contractor shall not assign this Agreement or the performance of any obligations of Contractor under this Agreement, nor enter into any Subcontract in respect of the Work or any part thereof except in compliance with Article 10 hereof and with the prior written consent of BPCA, and each and every such assignment, Purchase Order and Subcontract without such compliance and consent shall be void and shall revoke and annul this Agreement.

11.2 No Assignment of Monies

Contractor shall not assign any monies payable hereunder nor execute and deliver any order for payment unless Contractor and the assignee shall have complied with the following terms and conditions:

(a) the assignee shall be a commercial bank or finance company regularly engaged in the business of provided financing to construction contractors and shall be providing such financing to Contractor;

(b) the assignee shall, simultaneously with the assignment, execute and deliver to BPCA an undertaking, in favor of BPCA, in form and substance satisfactory to BPCA, providing that:

(1) assignee will cause Contractor to apply for trust purposes, as defined in New York Lien Law Article 3-A (the “**Lien Law**”), all funds advanced by assignee to Contractor;

(2) assignee will file a copy of the assignment, containing the covenant required by the Lien Law, with the County Clerk of New York County and the head of the agency having charge of the underlying project;

(c) the assignee shall agree with BPCA in writing that BPCA and Contractor may modify any of the terms of this Agreement, including any of the terms of payment, without the consent of assignee;

(d) the assignee shall agree with BPCA in writing that after the effective date of the assignment, BPCA may make payment directly to any Subcontractor or Materialman without any liability to the assignee;

(e) the assignee shall agree with BPCA in writing that the assignee shall require and cause Contractor to keep his books and records in the form and manner described in New York Consolidated Laws Service Lien Law Article 3-A Section 75; and

(f) the assignee shall agree with BPCA in writing that the assignee will indemnify and hold BPCA harmless from and against any loss, claim or expense incurred as a result of any failure of performance in accordance with the terms of such undertaking.

11.3 Assignment by BPCA

This Agreement or any rights of BPCA under this Agreement, including any guaranties or warranties of workmanship or material, may at any time be assigned by BPCA to the State of New York or any political subdivision, public corporation or agency of the State.

ARTICLE 12 - MECHANICS’ LIENS AND CLAIMS

If any mechanic’s lien or other claim shall be filed for or on account of the Work, Contractor shall discharge such lien or claim within thirty days of receiving written notice of such lien or other claim.

ARTICLE 13 – INSURANCE AND CONTRACT SECURITY

13.1 Insurance

(a) Contractor shall procure and maintain all of the insurance required under this Article 13 until Final Acceptance of the Work, except with respect to Completed Operations Coverage, as described in 13.1(f)(3) below.

(b) Contractor shall not commence physical performance of the Work at the Site until Contractor has obtained, and required each Subcontractor to obtain, all the insurance required under this Article and until it has furnished to BPCA the certificate or certificates of insurance required by Section 13.1(c) hereof.

(c) Contractor shall furnish to BPCA, before or upon execution of this Agreement, attention: [name], a certificate or certificates of the insurance required under this Article and, upon BPCA's request, certified copies of the original policies of insurance, within the time period required by BPCA and before commencing physical performance of the Work at the Site. Such certificate or certificates shall be in form satisfactory to BPCA, shall list the various coverages and shall contain, in addition to any other provisions required hereby, a provision that the policy shall not be changed, canceled or reduced and that it shall be automatically renewed upon expiration and continued in force until two years after Final Acceptance unless BPCA is given 90 days' written notice to the contrary. Such certificates shall also include riders providing that violation of any of the terms of any policy shall not by itself invalidate such policy. Such policies and certificates should name as additional insureds BPCA, Battery Park City Parks Conservancy Corporation ("BPCPC"), the State of New York, Construction Manager, and Architect.

(d) All insurance required to be procured and maintained must be procured from insurance companies that have a financial rating by A.M. Best Company as published in the most current key rating guide of "A-X" or better and which are authorized to do business in the State of New York.

(e) If at any time any of the required insurance policies should be canceled, terminated or modified so that insurance is not in effect as required, then, if BPCA shall so direct, Contractor shall suspend performance of the Work. If the Work is not suspended then BPCA may, at BPCA's option, obtain insurance affording coverage equal to that required, the cost of such insurance to be payable by Contractor to BPCA.

(f) Contractor and each Subcontractor shall secure in a form satisfactory to BPCA:

(1) Worker's Compensation and Employer's Liability Insurance (including United States Longshoreman & Harbor Workers and Jones Act Coverages) during the Term for the benefit of such employees as are required to be insured by the applicable provisions of law and voluntary compensation for employees excluded from statutory benefits. Employer's Liability Insurance and benefits resulting from disease shall not be less than an annual aggregate amount of (\$\$\$\$\$) for each consecutive 12-month period.

(2) Disability Benefit Insurance during the life of this Agreement for the benefit of such employees as are required to be insured by the applicable provisions of law.

(3) Commercial General Liability Insurance as follows:

Standard commercial general liability insurance policy with contractual, products and completed operations and explosion, blasting, collapse, excavation and underground damage liability coverages, under the occurrence policy format, issued to and covering the liability of Contractor for all the Work and operations relating thereto and all obligations assumed by Contractor under this Agreement including, but not limited to indemnity obligations in an amount which shall not be less than the following limits:

Combined Single Limits, Bodily Injury and Property Damage Liability

(\$\$\$\$\$) per each occurrence and (\$\$\$\$\$) in the aggregate.

Product and Completed Operations

(\$\$\$\$\$)

The completed operations coverage shall continue in force until three years after Final Acceptance of the Work and shall contain, in addition to any other provisions required hereby, a provision that the policy shall not be changed, canceled or reduced. As a condition precedent to the making of Final Payment, Contractor shall furnish BPCA with a certified copy of the completed operations policy.

(4) Automobile Liability Insurance as follows:

A policy covering the use in connection with the Work of all owned, non-owned and hired vehicles bearing license plates, or under the circumstances that such vehicles are being used they are required by the Motor Vehicle Laws of the State of New York to bear license plates. The coverage under such policy shall not be less than the following limits:

Combined Single Limits,

Bodily Injury and Property Damage Liability

(\$\$\$\$\$) per each occurrence.

(5) Marine Protection and Indemnity insurance of not less than [amount] per occurrence, if Contractor or any of its Subcontractors utilizes floating equipment, barges or floats, or performs marine-related construction, covering any and all claims for personal injury, death and property damage arising out of or in connection with this Agreement.

(6) Pollution Liability Insurance, on an occurrence basis, providing coverage for bodily injury liability, property damage or environmental damage caused by pollution conditions with a limit of liability of not less than [amount] per occurrence and in the aggregate. The policy shall include coverage for environmental clean-up on land, in air and on water. The policy shall include coverage for completed operations for two (2) years after the completion of the performance of the Work, gradual and sudden and accidental pollution coverage, with a time element of no less than seven (7) days' notice and thirty (30) days' reporting. The policy shall not

contain a sunset provision, or any other provision, which would prohibit the reporting of a claim and the subsequent defense and indemnity that would normally be provided by the policy. The policy shall provide transportation coverage for the hauling of hazardous materials from the Project Site to the final disposition location.

(7) Vessel Pollution Liability Insurance, on an occurrence basis, providing coverage for bodily injury liability, property damage or environmental damage caused by pollution conditions, emanating from any floating equipment, barges or floats, utilized by Contractor or Subcontractors in the performance of Marine related construction, with a limit of liability of not less than [amount] per occurrence and in the aggregate. The policy shall include coverage for environmental clean-up on land, in air and on water.

(8) Contractor shall secure, pay for, and maintain Property Insurance necessary for protection against the loss of owned, borrowed or rented equipment, tools and materials used in Contractor's performance of the Work. The requirement to secure and maintain such insurance is solely for the benefit of Contractor. Contractor's failure to secure such insurance or to maintain adequate levels of coverage shall not render BPCA or any other Additional Insureds, or their agents and employees, responsible for any such losses, and Owner, the other Additional Insureds, and their agents and employees shall have no such liability.

(9) Valuable Papers Insurance insuring, for the benefit of Contractor and BPCA all plans, designs, drawings, specifications, and documents used under this Agreement by Contractor in a total amount of not less than [\$\$\$\$\$\$] Contractor may furnish full coverage under one policy, or may submit separate policies from any Subcontractor(s) for their proportionate shares of such coverage.

(10) Comprehensive Crime/Employee Dishonesty Insurance in a reasonable amount or an amount which is customary in the applicable industry, trade or profession.

(11) If the Work involves the removal, repair, installation or testing of underground petroleum storage tanks, or petroleum remediation operations, or the performance of work or services related to excavation, loading, transporting or unloading of hazardous or contaminated materials, Contractor shall provide Contractors Professional Liability Insurance with a limit of [\$\$\$\$\$]. Coverage shall provide and encompass the following:

(i) Contractor's negligent acts, errors or omissions in rendering or failing to render services of an engineering or consulting nature arising out of their environmental engineering or consulting.

(ii) Maximum self-insured retention of [\$\$\$\$\$], or an amount acceptable to BPCA.

(12) Umbrella Liability Insurance [excess of general liability, automobile liability, Marine protection and indemnity, pollution liability, vessel pollution liability and Employer's Liability] in an amount of not less than [amount].

(g) The insurance required under subsections 13.1(f) 3, 4 [and 5] shall be of a type which shall protect Contractor and Subcontractors, respectively, against damage claims which may

arise from operations under this Agreement, whether such operations be by the insured or by anyone directly or indirectly employed by the insured. Each of the aforesaid policies shall provide that the insurance company or an attorney approved and retained by the insurance company shall defend any suit or proceeding against BPCA or any officers, agents or employees of BPCA whether or not such suit is groundless, false or fraudulent. Notwithstanding the foregoing, BPCA shall have the right to engage its own attorneys for the purpose of defending any suit or proceeding against it or its respective officers, agents or employees, and, in such event, Contractor shall indemnify BPCA for all attorneys' fees and disbursements and other costs incurred by it arising out of, or incurred in connection with, any such defense. The said insurance shall name BPCA, BPCPC, the State of New York, Construction Manager and Architect as additional insureds as respects this location and shall, where applicable, be written on an occurrence basis and shall contain a provision that it is primary and that any similar insurance which BPCA, BPCPC, the State of New York, Construction Manager, Architect, Contractor or Subcontractor elect to carry for their own benefit is secondary or excess and not contributing insurance.

(h) BPCA, at BPCA's cost and expense, may, at its sole option, procure and maintain such insurance as shall in the opinion of BPCA, protect BPCA from contingent liability of BPCA to others for damages arising from bodily injury, including death and property damages which may arise from operations under this Agreement. The procurement and maintenance of such insurance by BPCA shall not in any way be construed or be deemed to relieve Contractor from, or to be a limitation on the nature or extent of, such obligations and risk.

(i) BPCA shall, at all times during the period of construction and until completion and Final Acceptance of the Work procure and maintain at the cost and expense of BPCA "**Builders Risk**" insurance, or its functional equivalent, against direct physical loss or damage to the Work and on all Materials to be made a part of the Work in the names of BPCA, Construction Manager, Contractor and Subcontractors, said amount of insurance to be procured and maintained on a one hundred percentage (100%) completed value basis on the insurable portion of the Work, which insurance shall contain a deductible provision for all losses except flood and earthquake in the amount of TEN THOUSAND DOLLARS (\$10,000) and a deductible provision for flood and earthquake in the amount of TEN THOUSAND DOLLARS (\$10,000). BPCA recognizes that the deductible applicable to flood and earthquake may be greater than TEN THOUSAND DOLLARS (\$10,000) due to insurance market conditions and shall notify Contractor if such deductible is greater than TEN THOUSAND DOLLARS (\$10,000). Losses up to and including the amounts of such deductible provisions shall be borne by Contractor. The insurance specified above may, in certain instances, include other parties as named insureds, as the interests of such parties may appear. Loss, if any, is to be made adjustable with and payable to BPCA on behalf and for the named insureds as the interests of such insureds may appear. BPCA shall, in BPCA's sole discretion, have power to adjust and to settle with the insureds any loss or claim under such insurance. The above is not intended to be a complete, full or accurate description of the coverage provided by the policies of insurance, copies of which are on file with BPCA. This subsection (i) is not intended to create or give any rights to Contractor or Subcontractors other than those which may be made available to such Contractors or Subcontractors under the terms of such policies. BPCA assumes no obligation to obtain insurance other than that evidenced by said policies. Contractor and Subcontractors shall not violate or permit to be violated any term or condition of such policies and shall at all times satisfy the safety requirements of BPCA and of the insurance companies issuing the aforementioned policies. The Contractor shall, upon notification by BPCA,

obtain such insurance at BPCA's expense on a date determined by BPCA, which date shall not be less than thirty (30) days after notice to Contractor of such determination by the BPCA.

13.2 Effect of Procurement of Insurance

Neither the procurement nor the maintenance of any type of insurance by BPCA or Contractor shall in any way be construed or be deemed to limit, discharge, waive or release Contractor from any of the obligations and risks impressed upon Contractor by this Agreement or to be a limitation on the nature or extent of such obligations and risks.

13.3 Contract Security

Contractor shall, if it has not already done so, furnish to BPCA, with the execution of this Agreement, to BPCA, a bond in the form acceptable to BPCA in an amount at least equal to one hundred percent (100%) of the Contract Price for performance of the Work (the "**Performance Bond**"), and a labor and material payment bond in the form acceptable to BPCA in an amount at least equal to one hundred percent (100%) of the Contract Price for the payment of all persons performing labor or providing Materials in connection with the Work (the "Payment Bond"). The surety on said bond shall be a surety company authorized to do business in the State of New York and shall be rated at last B+ by A.M. Best and Company, or meet such other requirements as are acceptable to BPCA.

13.4 Additional or Substitute Bond

If at any time BPCA shall be or shall become dissatisfied with any surety or sureties then obligated upon the Performance Bond or the Payment Bond, or if for any other reason such bonds shall cease to be adequate security to BPCA, Contractor shall within five (5) days after notice from BPCA to do so, substitute an acceptable bond or bonds in such form and sum and signed by such other surety or sureties as may be satisfactory to BPCA, except that the penal sum of said bond shall not exceed the Contract Price as adjusted by Change Orders. No further payments shall be deemed due nor shall be made until the new surety or sureties shall have furnished such an acceptable bond or bonds to BPCA.

ARTICLE 14 - CLAIMS FOR EXTRA WORK

(a) If Contractor is of the opinion that (i) any work that it has been ordered to perform is Extra Work and not Work as set forth in the Contract Documents, (ii) any action or omission of BPCA, Construction Manager or Architect is contrary to the terms and provisions of the Contract Documents and will require the performance of Extra Work or will cause additional expense to Contractor or (iii) any determination, order or directive of BPCA, Construction Manager or Architect is contrary to the terms of the Contract Documents and will require the performance of Extra Work or will cause additional expense to Contractor, Contractor shall:

(1) promptly comply with each determination, order or directive and proceed diligently with the performance of the Work in accordance with BPCA's instructions,

(2) notify BPCA, Construction Manager and Architect in writing within 72 hours of such determination, order, act or omission that Contractor believes such will require it to

perform Extra Work or incur additional expense and the basis for Contractor's conclusion and request a final determination thereon by BPCA; and

(3) present to the Construction Manager for signature daily time and Material tickets to confirm quantities of Material and hours of labor in cases where Contractor is performing the Work which it considers to be Extra Work.

If BPCA determines that (x) such work is Work required to be performed hereunder and not Extra Work, (y) such action or omission is proper, or (z) such determination, order or directive is proper, Contractor, in order to reserve its right to claim compensation for or damages resulting from the performance of such work or the compliance with such determination, order or directive, must notify BPCA in writing within three (3) working days after receiving notice of BPCA's determination that it is performing such work or complying with such determination, order or directive under protest.

In addition to the foregoing, Contractor must submit to BPCA, Construction Manager and Architect within thirty (30) days after it has performed such work or complied with such determination, order or directive, a detailed statement of the extra expense claimed to have been incurred and of any claimed damages resulting from the performance of such work or the compliance with such determination, order or directive.

(b) No claim for Extra Work shall be allowed unless the same was done pursuant to written order approved in writing by BPCA. Contractor's failure to comply with any provision of this Article:

(1) shall constitute a conclusive and binding determination on the part of Contractor that such action, omission, determination, order or directive does not involve Extra Work, has not caused extra expense or damages to Contractor, and is not contrary to the terms and provisions of the Contract Documents; and

(2) shall constitute an irrevocable waiver by Contractor of any claim for compensation for or damages resulting from the performance of such work or the compliance with such determination, order or directive.

(c) The value of claims for Extra Work, if allowed, shall be determined by the methods described in Section 9.2(a).

ARTICLE 15 - TERMINATION

15.1 Termination for Cause

(a) If any of the following events shall occur (an "**Event of Default**") then BPCA or Construction Manager may serve written notice upon Contractor and upon Contractor's surety, if any, terminating this Agreement at a specified date. The notice shall contain the reasons for termination but shall not be effective to terminate this Agreement if Contractor cures all Events of Default stated in the notice prior to the date specified in the notice of termination.

(1) Contractor shall violate any substantial provision of this Agreement,

including, without limitation, by failing to maintain the Progress Schedule for the Project or Progress Schedule for the Work then in effect in accordance with, or failing to discharge any of its responsibilities under, Section 3.1(d) hereof, including abandonment of the Work by Contractor, or by failing to indemnify and hold harmless BPCA (as required by Sections 3.1(e), 3.2, 17.5, 21.1, 21.2, 22(c) or any other provision of this Agreement) from and against any and all claims, liabilities, losses, costs or damages arising out of Contractor's performance of, or failure to perform, its obligations under this Agreement in accordance with its terms, or if the Contractor fails to maintain the insurance required by the provisions of Section 13; or

(2) any material adverse change shall take place in the financial condition of the Contractor;

(3) Contractor takes any action which would result in it becoming the subject of any insolvency proceeding. The term "insolvency proceeding" as used herein shall include the filing of a petition for relief under Title 11 of the United States Code by Contractor or the consent, acquiescence or taking of any action by Contractor, or the filing by or against Contractor of petition or action, looking to or seeking any reorganization, arrangement, composition, readjustment, liquidation, dissolution, or similar relief under any other regulation; or the appointment, with or without the consent of Contractor, of any trustee, custodian, receiver or liquidator of Contractor or of any property or assets of Contractor; or Contractor's making of an assignment for the benefit of creditors or its inability to pay its debts as they become due;

(4) Contractor misrepresented or omitted information in its submission of the Statement of Qualifications of Contractor submitted by Contractor to BPCA in connection with this Agreement; or

(5) any partner, principal, director, officer or shareholder owning in excess of five percent (5%) of the stock of Contractor shall have been convicted of a felony.

(b) Upon the occurrence of an Event of Default, at BPCA's option exercised by written notice to Contractor, title to any or all of Contractor's Materials, equipment, work product, work in process and dies and tools, whether on the Site or off site, which are necessary or useful in completing the Work shall vest in BPCA and BPCA may take possession of and utilize the same for completion of the Work; provided that title to such items shall revert to Contractor upon effectuation of a cure of the Event of Default prior to the termination of this Agreement. If no cure has been effected, this Agreement has been terminated and BPCA has taken possession of the same, then after BPCA has taken possession and the Work shall have been completed by or on behalf of BPCA, BPCA shall pay to Contractor, in respect to the items for which title has vested in BPCA, an amount equal to the sum of:

(1) the direct costs of Contractor for such Materials and Work in progress, and

(2) the depreciated book value of such tools and dies less, if BPCA elects to return the tools and dies to Contractor, the salvage value thereof. BPCA shall have the right to set off against such payment due to Contractor any amounts then due and payable by Contractor to BPCA which may accrue as damages owing by Contractor to BPCA under the terms of this Agreement. Contractor shall execute any further documents (including Form UCC-1 Financing

Statements to give public notice of the potential ownership interest of BPCA as set forth herein) required by BPCA to confirm the terms of this subsection 15.1(b).

(c) Upon termination of this Agreement, BPCA shall have the right, in addition to all other rights and remedies, to complete or have the Work completed by such means and in such manner, by contract or otherwise, with or without public letting as permitted by law, as BPCA deems advisable. BPCA may deduct any loss it incurs thereby from any payment then or thereafter due to Contractor without prejudice to any other remedy BPCA may have.

(d) Immediately upon termination in accordance with the provisions of this Section, each and every Subcontract and Purchase Order entered into by Contractor shall, at BPCA's option, be automatically assigned to BPCA, and Contractor shall insert a provision to this effect in all Subcontracts and Purchase Orders.

(e) Contractor shall, upon the date when such termination shall take effect, promptly notify the union or unions, if any, having jurisdiction over the work by its employees that it releases the Project and consents that the Work be performed by others and Contractor expressly authorizes BPCA to notify the union or unions of such release in the name of Contractor. The failure, neglect or refusal of Contractor to issue such release or the disclaimer by it of the effectiveness of the release issued by BPCA shall subject Contractor to all damages sustained by BPCA.

(f) If this Agreement shall have been terminated by BPCA pursuant to this Section 15.1 and it shall be finally determined by BPCA or a court of competent jurisdiction that adequate grounds for such termination did not exist, then such termination shall be deemed a termination for convenience of BPCA under Section 15.2 hereof and the sole right, remedy and recourse of Contractor against BPCA shall be governed and determined by Section 15.2 hereof.

15.2 Termination for Convenience of BPCA

(a) BPCA, at any time, may terminate this Agreement for its own convenience. Any such termination shall be effected by delivering to Contractor a notice of termination specifying the extent to which performance of Contractor's Work under the Contract is terminated and the date upon which such termination becomes effective. Upon receipt of the notice of termination, Contractor shall:

(1) stop work under this Agreement on the date specified in the notice of termination;

(2) place no further Purchase Orders or Subcontracts for Materials, services or facilities;

(3) unless directed otherwise by BPCA, terminate all Purchase Orders and Subcontracts;

(4) assign to BPCA, in the manner, at the times, and to the extent directed by Construction Manager, all of the right, title and interest of Contractor under the Purchase Orders and Subcontractors so terminated, in which case BPCA shall have the right, in its sole discretion, to settle or pay any or all claims arising out of the termination of such Purchase Orders and

Subcontracts;

(5) to the extent required by Construction Manager, settle all outstanding liabilities and all claims arising out of such termination of Purchase Orders and Subcontracts, with the approval or ratification of Construction Manager, which approval or ratification shall be final for all the purposes of this Section 15.2;

(6) transfer title to BPCA and deliver in the manner, at the time, and to the extent, if any, directed by the Construction Manager (i) the fabricated or unfabricated parts, Work in process, completed Work, supplies, and other Material produced as a part of, or acquired in connection with the performance of, the Work terminated by the notice of termination, and (ii) the completed or partially completed plans, drawings, work product, information and other property, which if this Agreement had been completed, would have been required to be furnished to BPCA; and

(7) take such action as may be necessary, or as the Construction Manager may direct, for the protection and preservation of the property related to this Agreement which is in the possession of Contractor and in which BPCA has or may acquire an interest.

(b) In the event of a termination of this Agreement pursuant to this Section 15.2, Contractor shall be paid by BPCA only the apportioned Contract Price for Work installed, the fair and reasonable value of Materials stored on the Site and under order for which Contractor is responsible for payment, less any sums properly deductible by BPCA, except that in no event shall Contractor be entitled to compensation in excess of the total Contract Price.

15.3 Suspension of Work

(a) BPCA may at any time and for any reason direct Contractor to suspend, stop, or interrupt the Work or any part thereof for a period of time. Such direction shall be in writing and shall specify the period during which the Work is to be stopped. Upon receipt of a direction of suspension, Contractor shall, as soon as practicable, cease performance of the Work as ordered and take immediate affirmative measures to protect the Work from loss or damage. Contractor shall resume the Work upon the date specified in such direction or upon such other date as BPCA may thereafter specify in writing.

(b) The period during which the Work shall have been suspended, stopped or interrupted may, if warranted, be added to the time fixed for performance. A suspension, stoppage or interruption of the Work pursuant to this provision shall not give rise to any claim against BPCA for additional compensation.

ARTICLE 16 - COMPOSITE DRAWINGS AND COOPERATION

Where Contractor shall perform Work in close proximity to work of other contractors or subcontractors, or where there is evidence that Contractor's Work may interfere with work of other contractors, or subcontractors, Contractor shall assist in arranging space conditions to make satisfactory adjustment for the performance of such work and the Work. Contractor shall prepare composite scale working drawings and specifications as directed by Construction Manager, clearly showing how Contractor's Work is to be performed in relation to work of other contractors or

Subcontractors. Such direction may include the following: the scale of the drawings, where the drawings are to be drafted, the number of prints or reproducibles, and the requirement of attendance at meetings. The determination as to who shall provide the composite drawings and the contents of the same shall rest exclusively with Construction Manager. Upon request by Construction Manager, Contractor shall sign and be bound by such composite drawings. Such signature shall indicate Contractor's acknowledgment that such drawing is acceptable as related to its Work covered or included in such drawing. If Contractor performs the Work in a manner that causes interference with the work of other contractors, or Subcontractors, Contractor shall make the changes necessary to correct the condition as directed by Construction Manager.

ARTICLE 17 - PROTECTION OF RIGHTS, PERSONS AND PROPERTY

17.1 Accident Prevention

Contractor shall at all times take every precaution against injuries to persons or damage to property and for the safety of persons engaged in the performance of the Work.

17.2 Safety Programs

Contractor shall be responsible for the initiation, maintenance and supervision of safety precautions and programs as prescribed by Construction Manager in connection with the Work.

17.3 Protection of Work and Property

(a) Contractor shall at all times guard BPCA's property from injury or loss in connection with the Work. Contractor shall at all times guard and protect the Site, the Work and adjacent property. Contractor shall replace or make good any such loss or injury unless such loss or injury is caused directly by BPCA.

(b) Contractor shall have full responsibility to install, protect and maintain all Materials in proper condition and forthwith repair, replace and make good any damage thereto until Final Acceptance of the Work.

(c) No provision is included for stresses or loads imposed by construction operations. If Contractor desires to place such loads in excess of the design load (as shown on the Drawings or Specifications), Contractor shall submit to Architect drawings and calculations prepared by, and bearing the seal of a professional engineer, showing the proposed method for supporting such loads, for Architect's review and approval. No loading of any kind in excess of design loads shall be placed on any part of the Project prior to Architect's approval of such submitted drawings and calculations. The costs of the Architect's review shall be reimbursed to BPCA by Contractor.

(d) Contractor shall be responsible for all cutting, fitting or patching that may be required to complete the Work, to make its several parts fit together properly and to make the Work fit together properly with previous and surrounding work. The requirement to cut, fit or patch shall be determined by Construction Manager; provided, that structural elements of the Project shall not be cut, patched, or otherwise altered or repaired without prior authorization by BPCA. Authorization to proceed with remedial operation on any damaged or defective element or portion of the Project shall not constitute a limitation or a waiver of BPCA's, Construction Manager's or

Architect's right to require the removal and replacement of any Work which fails to fulfill the requirements of the Contract Documents.

17.4 Adjoining Property

Contractor shall protect all adjoining property and shall repair or replace any such property damaged or destroyed during the progress of the Work.

17.5 Risks Assumed by Contractor

(a) Contractor solely assumes the following risk whether such risk arises from acts or omissions (whether negligent or not and whether supervisory or otherwise) of BPCA, Construction Manager, of Architect or Contractor, of any Subcontractor, of any Materialman, of third persons or from any other cause, including unforeseen obstacles and difficulties which may be encountered in the prosecution of the Work, whether such risk is within or beyond the control of Contractor and whether such risk involves any legal duty, primary or otherwise, imposed upon BPCA:

The risk of loss or damage, direct or indirect, of whatever nature, to the Work or to any Materials furnished, used, installed or received by BPCA, Contractor or any Subcontractor, Materialmen or workmen performing services or furnishing Materials for the Work, whether such Work or Materials are stored at the Site or at an offsite location in accordance with Section 5.4 hereof. Contractor shall bear such risk of loss or damage until Final Acceptance of the Work by BPCA or until completion of such Materials or removal of such Materials from the Site following a determination that they will no longer be needed for the Project and delivery to the location at which they are to be subsequently stored or disposed of, whichever event occurs last. A portion of the risk of such loss or damage may be insured against under the terms of a "builder's risk" insurance policy maintained in the name of Contractor, among others, as described in Section 13.1(i). Notwithstanding the status of any actual or potential recovery or claim under the said "builder's risk" insurance policy, in the event of any loss or damage, Contractor immediately shall repair, replace or make good any such loss or damage.

(b) Contractor shall not, without obtaining express advance permission of BPCA, raise any defense involving in any way the: (i) jurisdiction of any court in which BPCA brings an action arising under this Agreement, (ii) the governmental nature of BPCA, or (iii) the provisions of any statutes respecting suits against BPCA.

(c) Contractor's obligations under this Article 17 shall not be deemed waived, limited or discharged by the enumeration or procurement of any insurance for liability for damages.

(d) Neither Final Acceptance of the Work nor any payment made hereunder shall release Contractor from Contractor's obligations under this Article 17. The enumeration elsewhere in this Agreement of particular risks assumed by Contractor or of particular claims for which Contractor is responsible shall not be deemed to limit the effect of the provisions of this Article 17 or to imply that Contractor assumes or is responsible for only risks or claims of the type enumerated; and neither the enumeration in this Article 17 nor the enumeration elsewhere in this Agreement of particular risks assumed by Contractor of particular claims for which Contractor is responsible shall be deemed to limit the risks which Contractor would assume or the claims for which Contractor would be responsible in the absence of such enumerations.

(e) The Contractor is advised that the Work under this Agreement may impose certain obligations and requirements mandated by the U.S. Department of Labor Occupational Safety and Health Administration regulations, Title 29 CFR Part 1926.62 Lead Exposure in Construction, relative to the potential exposure to lead by its employees. The Contractor assumes entire responsibility and liability for complying fully in all respects with these regulations.

(f) Contractor agrees that any unsatisfied claims of the BPCA arising from Contractor's obligations under this Article 17 or Article 13 (Insurance) may be offset or deducted by BPCA from any payments due to Contractor hereunder.

ARTICLE 18 - USE PRIOR TO ACCEPTANCE BY BPCA

(a) If before Final Acceptance of Work, BPCA desires to use the Site or any part thereof that is completed or partly completed, or to place or install therein or thereon equipment, BPCA shall have the right to do so, and Contractor shall in no way interfere with or object to such use by BPCA.

(b) Such use shall not (1) constitute acceptance of space, systems, Materials or elements of the Work, (2) affect the start of any guaranty period, nor (3) affect the obligations of Contractor to complete the Work in accordance with the requirements of this Agreement or other obligations of Contractor under the Contract Documents.

(c) Contractor shall continue the performance of the Work in a manner that shall not unreasonably interfere with such use by BPCA.

ARTICLE 19 - EXEMPTION FROM SALES AND COMPENSATING USE TAXES

19.1 BPCA Exempt

BPCA is exempt from payment of sales and compensating use taxes of the State of New York and of cities and counties thereof on all Materials that will become an integral component of the completed Project pursuant to this Agreement.

19.2 Certificates

Contractor shall obtain and cause Subcontractors and Materialmen to obtain any and all necessary certificates or other documentation from the appropriate governmental agency or agencies, and use such certificates or other documentation as required by law, rule or regulations to obtain said tax exemption.

ARTICLE 20 - WARRANTIES AND GUARANTIES

20.1 In General

(a) Contractor guarantees that all Work performed and all Materials furnished will conform to the Contract Documents as to kind, quality, functions, design and characteristics of material and workmanship. Contractor shall remove, replace and repair, at its sole cost and expense, all defects in workmanship, Materials, ratings, capacities, or design characteristics

occurring in or to the Work including, without limitation, any portion of the Work furnished or performed by any Subcontractor or Materialman, within one year from the date of Final Acceptance. Contractor guarantees that all Work performed and all Materials furnished will conform to the Contract Documents as to kind, quality, functions, design and characteristics of material and workmanship. Contractor hereby acknowledges that BPCA may be required to incur substantial expense if correction of the Work is required particularly if such correction involves the uncovering, removal or replacement of concrete, wiring and piping installed at the Site. If Contractor shall fail to reimburse BPCA for any such expense which may become payable as provided in this paragraph, BPCA shall be entitled to deduct such expense from any payments required to be made by BPCA to Contractor pursuant to this Agreement. Contractor, upon demand, shall pay for any and all damage to any Work affected by or from such defects and all expenses necessary to remove, replace and repair such Work that may be damaged in removing, replacing or repairing such defects.

(b) The benefits of this Article 20 shall inure to the benefit of BPCA and its respective successors and assigns. In addition, any bond or guaranty that may be required of Contractor or any Subcontractor or Materialman under the Contract Documents shall inure to the benefit of BPCA and its respective successors and assigns.

(c) The rights and remedies afforded BPCA under this Section are in addition to and not in lieu of and do not in any way affect, change, alter, modify, vary or prejudice any right, remedy or recourse that BPCA may have under other provisions of this Agreement or pursuant to law.

20.2 Additional Guaranties

In addition to the general guaranty set forth in Section 20.1, any other guaranties set forth in the Contract Documents shall be applicable.

20.3 Repair by Another

If BPCA has requested Contractor to correct any Work and Contractor shall not have completed any correction of the Work as shall be required pursuant to this Article 20 within ten (10) working days after receipt of written notice from BPCA specifying the defect or damage required to be removed, replaced or repaired, or if such defect or damage is of such a nature that it cannot be completely removed, repaired and replaced within such ten (10) day period and Contractor shall not have diligently commenced removing, repairing and replacing such defect and damage within such ten (10) day period or shall not thereafter with reasonable diligence and in good faith proceed to do such work, BPCA may employ such other person, firm or corporation as it may choose, to perform such removal, replacement and repair, and Contractor shall, upon demand, pay to BPCA all amounts that BPCA expends for such removal, replacement and repair.

ARTICLE 21 - INDEMNITY

21.1 Delay or Failure

Contractor and its sureties shall be responsible for and pay to BPCA, all loss, damage and additional cost incurred by reasons or on account of (i) the unexcused delays of Contractor

(determined as set forth in Section 3.1 hereof) or (ii) Contractor's failure to fully and completely carry out the terms of this Agreement.

21.2 Inventions

In addition to the indemnity set forth in Section 17.5(a), Contractor shall indemnify and hold BPCA harmless from all claims, demands or liabilities of any kind or nature, including costs and expenses, for or on account of any patented or unpatented plan, design, invention, article, arrangement, appliance, Material, or preparation, manufactured, used or followed in the performance of or incident to the Work hereunder, and shall defend any and all actions arising out of the same. In the event of any injunction or legal action by reason thereof, which shall operate to stop or retard the Work, BPCA shall have the right to substitute such other articles of like kind as will enable it to complete the Project, and all costs and expenses occasioned thereby shall be borne by Contractor.

21.3 Liability

To the fullest extent allowed by law, Contractor shall hold BPCA, BPCPC, the State of New York, Construction Manager and Architect and their servants, agents and employees harmless from and shall indemnify them against any and all liability, loss, cost, damage or expense, including attorneys' fees, by reason of claims of Contractors employees or employees of its Subcontractors or Materialmen for injuries or death or by reason of claims of any other person or persons, including BPCA, BPCPC, the State of New York, Construction Manager, and Architect and their servants, agents or employees, for injuries to person or property or for death occasioned in whole or in part by any act or omission of Contractor, its Subcontractors and Materialmen and their servants, agents and employees whether or not it is contended that BPCA contributed thereto or was responsible therefor by reason of nondelegable duty. If, however, this indemnification is limited by applicable law, then the said indemnification hereby shall be similarly limited to conform with such law, it being the intention that this indemnification shall be as permitted by applicable law. BPCA may retain any monies due or to become due hereunder sufficient to indemnify BPCA, BPCPC, the State of New York, Construction Manager, and Architect and their servants, agents and employees against such injuries, claims, suits, actions, costs or damages should any such claim arise. Contractor shall, at the sole option of BPCA and upon written demand of BPCA, assume the defense in behalf of BPCA, BPCPC, the State of New York, Construction Manager, and Architect or their servants, agents or employees of any action or proceeding commenced against them whether or not Contractor is named as a party therein as part of Contractor's aforementioned obligation to indemnify and hold them harmless.

ARTICLE 22 - PATENTS AND ROYALTIES

(a) In the prosecution of the Work, Contractor will not use or furnish any patented appliance, article, device or method of construction unless it has authorization for such use. Contractor shall pay all royalty and license fees.

(b) Any approval of Materials by Architect shall be construed merely as an approval of their adequacy for the Work.

(c) Contractor will be responsible for all claims against BPCA for the infringement of

any patents. Contractor shall defend all suits and claims for infringement of any patent rights and shall indemnify and hold BPCA harmless from loss on account thereof. Any expenses incurred by Contractor in connection with suits and claims will not offset the Contract Price.

(d) Contractor hereby and presently grants to BPCA an irrevocable and non-exclusive license to utilize all of the Contractor's rights in and to all:

- (1) United States patents and patents registered in any other foreign country;
- (2) proprietary knowledge, data and trade secrets; and
- (3) Engineering data and information necessary in connection with and solely in connection with, all work performed by BPCA or other contractors hired by BPCA to complete the work after termination of this Agreement pursuant to Section 15.1.

Each Purchase Order and Subcontract shall contain a similar clause with respect to the rights of Subcontractor and Materialman in and to the foregoing, in form and substance acceptable to BPCA, granting BPCA the aforesaid license. BPCA shall not be obligated to pay any royalties, license fees or any other consideration to Contractor or any Subcontractor or Materialman for this license. Contractor and each Subcontractor and Materialman shall execute a separate license agreement, in form and substance satisfactory to BPCA, concurrently with the execution of this Agreement, or any Subcontract or Purchase Order, or within ten (10) days thereafter, embodying the terms of this Section. On request, Contractor and each Subcontractor and Materialman shall furnish BPCA with copies of all related Engineering and technical data required to complete the work.

ARTICLE 23 - AS-BUILT DRAWINGS

(a) Contractor shall be furnished by BPCA, at BPCA's expense, with one physical set and two electronic copies (on disk) of 48" x 36" Drawings, on which Contractor, where applicable, shall record the installation of underground utilities, concealed piping, concealed valves and control equipment and record changes in the Work. Such recording shall be kept current and include final and actual sizes as well as the location and elevation of the above figures and offset distances in feet and inches to permanent surface improvements such as buildings, retaining walls or curbs. During the progress of the Work, at the request of Construction Manager and prior to the approval of any Requisition of Contractor, Contractor shall provide a 48" x 36" PDF to BPCA of the up to-date Drawings showing the Work as installed. At completion of the Work, Contractor shall complete, sign and date the 48" x 36" physical set of Drawings and deliver it to Architect.

(b) After review by Architect and return to Contractor for any required changes, Contractor shall furnish to BPCA, at Contractor's expense, at least one physical set and two electronic copies (on disk) of 48" x 36" final Drawings.

ARTICLE 24 - SHOP DRAWINGS AND SAMPLES

24.1 Contractor Submittal

Contractor shall submit to Construction Manager the shop drawings, Product Data and Samples required by the Contract Documents and shall adhere to all submittal and scheduling requirements with respect thereto. After review of such shop drawings, Product Data and Samples by Construction Manager and their approval by Architect, each of such items shall be returned in accordance with the procedures established therefor.

24.2 Contractor's Responsibility

Architect's approval of shop drawings, Product Data and Samples shall not relieve Contractor of responsibility for and deviation from the requirements of the Contract Documents. Contractor shall be responsible for the accuracy of the shop drawings, Product Data and Samples and for the conformity of Documents unless Contractor has notified Architect of the deviation in writing at the time of submission and has received from Architect written approval by separate letter of the specified deviations. Architect's approval shall not relieve Contractor of responsibility for errors or omissions in the shop drawings, Product Data or Samples.

ARTICLE 25 – NOTICES

Whenever it is provided herein that notice, demand, request, consent, approval or other communication shall or may be given to, or served upon, either of the parties by the other, or whenever either of the parties desires to give or serve upon the other any notice, demand, request, consent, approval or other communication with respect hereto, each such notice, demand, request, consent, approval or other communication shall be in writing and shall be effective for any purpose only if given or served by hand with proof of delivery, by delivery by an overnight courier service which obtains receipts, or by mailing the same by express or certified mail, postage prepaid, return receipt requested, addressed to:

- (a) if to BPCA:

Battery Park City Authority
Attn: [Name], [Title]
200 Liberty Street, 24th Fl
New York, NY 10281

with a copy to: General Counsel, at the same address

or to such other address as BPCA may from time to time designate in the manner set forth above.

- (b) if to Contractor:

[Company]
Attn: [Name], [Title]
[Street Address]

[City, State, Zip]

or to such other addresses as Contractor may from time to time designate in the manner set forth above.

- (c) if to Construction Manager

[Company]
Attn: [Name], [Title]
[Street Address]
[City, State, Zip]

or to such other addresses as the Construction Manager may from time to time designate in the manner set forth above.

- (d) if to Architect/Engineer/etc.

[Company]
Attn: [Name], [Title]
[Street Address]
[City, State, Zip]

or to such other addresses as Architect or Engineer may from time to time designate in the manner set forth above.

Every notice, demand, request, consent, approval or other communication hereunder shall be deemed to have been given or served (i) in the case of express or certified mail, on the date the receipt is dated by the Post Office or express mail carrier, as the case may be, and (ii) in the case of notice by hand or by overnight courier service, upon delivery, as evidenced by a signed receipt.

ARTICLE 26 – EMPLOYMENT AND DIVERSITY

26.1 Participation by Minority and Women-Owned Business Enterprises

- (a) General Provisions

(1) Owner is required to implement the provisions of New York State Executive Law Article 15-A and Parts 140-145 of Title 5 of the New York Codes, Rules and Regulations (“NYCRR”) for all contracts, as defined therein, with a value (1) in excess of \$25,000 for labor, services, equipment, materials, or any combination of the foregoing or (2) in excess of \$100,000 for real property renovations and construction.

(2) Contractor agrees, in addition to any other nondiscrimination provision herein and at no additional cost to Owner, to fully comply and cooperate with Owner in the implementation of New York State Executive Law Article 15-A and the regulations promulgated thereunder. These requirements include equal employment opportunities for minority group members and women (“EEO”) and contracting opportunities for New York State-certified minority and women-owned business enterprises (“MWBES”). Contractor’s demonstration of

“good faith efforts” pursuant to 5 NYCRR § 142.8 shall be a part of these requirements. These provisions shall be deemed supplementary to, and not in lieu of, the nondiscrimination provisions required by New York State Executive Law Article 15 (the “Human Rights Law”) and other applicable federal, state, and local laws.

(3) Failure to comply with all of the requirements herein may result in a finding of non-responsiveness, non-responsibility and/or a breach of contract, leading to the assessment of liquidated damages pursuant to Section 26.1(g) and such other remedies as are available to Owner.

(b) Contract Goals

(1) For purposes of this Contract, Owner hereby establishes an overall goal of XX% for MWBE participation, XX% for New York State-certified minority-owned business enterprise (“MBE”) participation and XX% for New York State-certified women-owned business enterprise (“WBE”) participation (collectively, “MWBE Contract Goals”) based on the current availability of MBEs and WBEs.

(2) For purposes of providing meaningful participation by MWBEs on the Agreement and achieving the MWBE Contract Goals established in Section 26.1(b)(1) hereof, Contractor should reference the directory of MWBEs at the following internet address: <https://ny.newnycontracts.com>.

(3) Additionally, Contractor is encouraged to contact the Division of Minority and Women’s Business Development at (212) 803-2414 to discuss additional methods of maximizing participation by MWBEs on this Agreement.

(4) Contractor understands that only sums paid to MWBEs for the performance of a commercially useful function, as that term is defined in 5 NYCRR § 140.1, may be applied towards the achievement of the applicable MWBE participation goal. [FOR CONSTRUCTION CONTRACTS – The portion of a contract with an MWBE serving as a supplier that shall be deemed to represent the commercially useful function performed by the MWBE shall be 60% of the total value of the contract. The portion of a contract with an MWBE serving as a broker that shall be deemed to represent the commercially useful function performed by the MWBE shall be the monetary value for fees, or the markup percentage, charged by the MWBE]. [FOR ALL OTHER CONTRACTS - The portion of a contract with an MWBE serving as a broker that shall be deemed to represent the commercially useful function performed by the MWBE shall be 25% of the total value of the contract.]

(5) Contractor must document “good faith efforts,” pursuant to 5 NYCRR § 142.8, to provide meaningful participation by MWBEs as Subcontractors and suppliers in the performance of this Agreement. Such documentation shall include, but not necessarily be limited to:

- (A) Evidence of outreach to MWBEs;
- (B) Any responses by MWBEs to Contractor’s outreach;
- (C) Copies of advertisements for participation by MWBEs in appropriate general circulation, trade, and minority or women-oriented publications;

- (D) The dates of attendance at any pre-bid, pre-award, or other meetings, if any, scheduled by Owner with MWBEs; and,
- (E) Information describing specific steps undertaken by Contractor to reasonably structure the Work to maximize opportunities for MWBE participation.

(c) Equal Employment Opportunity (“EEO”)

(1) The provisions of Article 15-A of the Executive Law and the rules and regulations promulgated thereunder pertaining to equal employment opportunities for minority group members and women shall apply to this Agreement.

(2) In performing the Agreement, Contractor shall:

(A) Ensure that each Contractor and Subcontractor performing work on the Agreement shall undertake or continue existing EEO programs to ensure that minority group members and women are afforded equal employment opportunities without discrimination because of race, creed, color, national origin, sex, age, disability or marital status. For these purposes, EEO shall apply in the areas of recruitment, employment, job assignment, promotion, upgrading, demotion, transfer, layoff, or termination and rates of pay or other forms of compensation.

(B) Contractor shall submit an EEO policy statement to Owner within seventy-two (72) hours after the date of the notice by Owner to award the Agreement to Contractor.

(C) If Contractor, or any of its Subcontractors, does not have an existing EEO policy statement, Owner may require Contractor or Subcontractor to adopt a model statement (see Exhibit D – Equal Employment Opportunity Policy Statement).

(D) Contractor’s EEO policy statement shall include the following language:

(i) Contractor will not discriminate against any employee or applicant for employment because of race, creed, color, national origin, sex, age, disability, or marital status, will undertake or continue existing EEO programs to ensure that minority group members and women are afforded equal employment opportunities without discrimination, and shall make and document its conscientious and active efforts to employ and utilize minority group members and women in its work force.

(ii) Contractor shall state in all solicitations or advertisements for employees that, in the performance of the contract, all qualified applicants will be afforded equal employment opportunities without discrimination because of race, creed, color, national origin, sex, age, disability or marital status.

(iii) Contractor shall request each employment agency, labor union, or authorized representative of workers with which it has a collective bargaining or other agreement or understanding, to furnish a written statement that such employment agency, labor union, or representative will not discriminate on the basis of race, creed, color, national origin, sex

age, disability or marital status and that such union or representative will affirmatively cooperate in the implementation of Contractor's obligations herein.

(iv) Contractor will include the provisions of Sections 26.1(c)(2)(D)(i) through (iii), which provides for relevant provisions of the Human Rights Law, in every subcontract in such a manner that the requirements of the subdivisions will be binding upon each Subcontractor as to the Work.

[PLEASE NOTE THAT THIS REQUIREMENT “C” IS ONLY APPLICABLE WHERE A STATE AGENCY EXPECTS TO ENTER INTO A STATE CONTRACT WITH A TOTAL EXPENDITURE IN EXCESS OF \$250,000. NOTE: THIS LANGUAGE SHOULD BE DELETED FROM THE FINAL CONTRACT]

(3) Staffing Plan. To ensure compliance with this Section, Contractor shall submit a staffing plan to document the composition of the proposed workforce to be utilized in the performance of the Agreement by the specified categories listed, including ethnic background, gender, and Federal occupational categories. Contractor shall complete the staffing plan form (<https://www.ogs.ny.gov/MWBE/Docs/EEO100.docx>) and submit it as part of their bid or proposal or within a reasonable time, as directed by Owner.

WORKFORCE UTILIZATION REPORTS SHALL BE COLLECTED ON A MONTHLY BASIS FOR CONSTRUCTION CONTRACTS AND A QUARTERLY BASIS FOR ALL OTHER CONTRACTS. NOTE: THIS LANGUAGE SHOULD BE DELETED FROM THE FINAL CONTRACT]

(4) Workforce Utilization Report

(A) Contractor shall submit a Workforce Utilization Report (https://its.ny.gov/sites/default/files/documents/eo_workforce_utilization_report.xlsx) and shall require each of its Subcontractors to submit a Workforce Utilization Report, in such form as shall be required by Owner on a monthly/quarterly basis during the term of this Agreement.

(B) Separate forms shall be completed by Contractor and any Subcontractors.

(C) Pursuant to Executive Order #162, Contractors and Subcontractors are also required to report the gross wages paid to each of their employees for the work performed by such employees on the contract on a monthly/quarterly basis.

(5) Contractor shall comply with the provisions of the Human Rights Law, and all other State and Federal statutory and constitutional non-discrimination provisions. Contractor and its Subcontractors shall not discriminate against any employee or applicant for employment because of race, creed (religion), color, sex, national origin, sexual orientation, military status, age, disability, predisposing genetic characteristic, marital status or domestic violence victim status, and shall also follow the requirements of the Human Rights Law with regard to non-discrimination on the basis of prior criminal conviction and prior arrest.

(d) MWBE Utilization Plan

(i) Contractor represents and warrants that Contractor has submitted an MWBE Utilization Plan, or shall submit an MWBE Utilization Plan at such time as shall be required by Owner, through the New York State Contract System (“NYSCS”), which can be viewed at <https://ny.newnycontracts.com>, provided, however, that Contractor may arrange to provide such evidence via a non-electronic method to Owner, either prior to, or at the time of, the execution of the contract.

(ii) Contractor agrees to adhere to such MWBE Utilization Plan in the performance of the Work.

(iii) Contractor further agrees that failure to submit and/or adhere to such MWBE Utilization Plan shall constitute a material breach of the terms of the Agreement. Upon the occurrence of such a material breach, Owner shall be entitled to any remedy provided herein, including but not limited to, a finding that Contractor is non-responsive.

(e) Waivers

(i) If Contractor, after making good faith efforts, is unable to achieve the MWBE Contract Goals stated herein, Contractor may submit a request for a waiver through the NYSCS, or a non-electronic method provided by Owner. Such waiver request must be supported by evidence of Contractor’s good faith efforts to achieve the maximum feasible MWBE participation towards the applicable MWBE Contract Goals. If the documentation included with the waiver request is complete, Owner shall evaluate the request and issue a written notice of approval or denial within twenty (20) business days of receipt.

(ii) If Owner, upon review of the MWBE Utilization Plan, quarterly MWBE Contractor Compliance Reports described in Section 26.1(c)(iv)(C), or any other relevant information, determines that Contractor is failing or refusing to comply with the MWBE Contract Goals, and no waiver has been issued in regards to such non-compliance, Owner may issue a notice of deficiency to Contractor. Contractor must respond to the notice of deficiency within seven (7) business days of receipt. Such response may include a request for partial or total waiver of MWBE Contract Goals.

(f) Contractor is required to submit a quarterly MWBE Contractor Compliance Report through the NYSCS, provided, however, that Contractor may arrange to provide such report via a non-electronic method to Owner by the 10th day following the end of each quarter during the term of the Agreement.

(g) Liquidated Damages - MWBE Participation

(1) Where Owner determines that Contractor is not in compliance with the requirements of this Section 26.1 and Contractor refuses to comply with such requirements, or if Contractor is found to have willfully and intentionally failed to comply with the MWBE participation goals, Contractor shall be obligated to pay to Owner liquidated damages.

(2) Such liquidated damages shall be calculated as an amount equaling the difference between:

(A) All sums identified for payment to MWBEs had Contractor achieved the contractual MWBE goals; and

(B) All sums actually paid to MWBEs for work performed or materials supplied under the Agreement.

(3) In the event a determination has been made which requires the payment of liquidated damages and such identified sums have not been withheld by Owner, Contractor shall pay such liquidated damages to Owner within sixty (60) days after they are assessed. Provided, however, that if Contractor has filed a complaint with the Director of the Division of Minority and Women's Business Development pursuant to 5 NYCRR § 142.12, liquidated damages shall be payable only in the event of a determination adverse to Contractor following the complaint process.

26.2 *Participation by Service-Disabled Veteran-Owned Businesses*

(a) General Provisions

Article 17-B of the New York State Executive Law provides for more meaningful participation in public procurement by New York State-certified Service-Disabled Veteran-Owned Businesses ("SDVOB"), thereby further integrating such businesses into New York State's economy. Owner recognizes the need to promote the employment of service-disabled veterans and to ensure that certified service-disabled veteran-owned businesses have opportunities for maximum feasible participation in the performance of Owner contracts.

In recognition of the service and sacrifices made by service-disabled veterans and in recognition of their economic activity in doing business in New York State, Contractors are expected to consider SDVOBs in the fulfillment of the requirements of the Agreement. Such participation may be as Subcontractors or suppliers, as protégés, or in other partnering or supporting roles.

(b) Contract Goals

(i) Owner hereby establishes an overall goal of ___% for SDVOB participation, based on the current availability of qualified SDVOBs. For purposes of providing meaningful participation by SDVOBs, the Contractor should reference the directory of New York State Certified SDVOBs found at: http://ogs.ny.gov/Core/docs/CertifiedNYS_SDVOB.pdf. Questions regarding compliance with SDVOB participation goals should be directed to Shinay Stewart at shinay.stewart@bpca.ny.gov or (212) 336-9353. Additionally, following execution of this Agreement, Contractor is encouraged to contact the Office of General Services' Division of Service-Disabled Veterans' Business Development at 518-474-2015 or VeteransDevelopment@ogs.ny.gov to discuss additional methods of maximizing participation by SDVOBs on the Agreement.

(ii) Contractor must document “good faith efforts” to provide meaningful participation by SDVOBs as subcontractors or suppliers in the performance of the Contract (see Section 26.2(d) below).

(c) SDVOB Utilization Plan

(i) In accordance with 9 NYCRR § 252.2(i), Contractors are required to submit a completed SDVOB Utilization Plan on Form SDVOB 100 (https://ogs.ny.gov/Veterans/Docs/2016/SDVOB_100_Utilization_Plan.docx) with their bid.

(ii) The Utilization Plan shall list the SDVOBs that Contractor intends to use to perform the Work, a description of the Work that Contractor intends the SDVOB to perform to meet the goals on the Agreement, the estimated dollar amounts to be paid to an SDVOB, or, if not known, an estimate of the percentage of Work the SDVOB will perform. By signing the Utilization Plan, Contractor acknowledges that making false representations or providing information that shows a lack of good faith as part of, or in conjunction with, the submission of a Utilization Plan is prohibited by law and may result in penalties including, but not limited to, termination of a contract for cause, loss of eligibility to submit future bids, and/or withholding of payments. Any modifications or changes to the agreed participation by SDVOBs after the contract award and during the term of the Agreement must be reported on a revised SDVOB Utilization Plan and submitted to Owner.

(iii) Owner will review the submitted SDVOB Utilization Plan and advise the Contractor of Owner acceptance or issue a notice of deficiency within 20 days of receipt.

(iv) If a notice of deficiency is issued, Contractor agrees that it shall respond to the notice of deficiency, within seven business days of receipt, by submitting to Owner a written remedy in response to the notice of deficiency. If the written remedy that is submitted is not timely or is found by Owner to be inadequate, Owner shall notify Contractor and direct the Contractor to submit, within five business days of notification by Owner, a request for a partial or total waiver of SDVOB participation goals on Form SDVOB 200 (https://ogs.ny.gov/Veterans/Docs/2016/SDVOB_200_Waiver_Form.docx). Failure to file the waiver form in a timely manner may be grounds for disqualification of the bid or proposal.

(v) Owner may disqualify a Contractor’s bid or proposal as being non-responsive under the following circumstances:

- (A) If Contractor fails to submit an SDVOB Utilization Plan;
- (B) If Contractor fails to submit a written remedy to a notice of deficiency;
- (C) If Contractor fails to submit a request for waiver; or
- (D) If Owner determines that Contractor has failed to document good faith efforts.

(vi) Contractor certifies that it will follow the submitted SDVOB Utilization Plan for the performance of SDVOBs on the Agreement pursuant to the prescribed SDVOB contract goals set forth above.

(vii) Contractor further agrees that a failure to use SDVOBs as agreed in the Utilization Plan shall constitute a material breach of the terms of the Contract. Upon the occurrence of such a material breach, Owner shall be entitled to any remedy provided herein, including but not limited to, a finding of Contractor non-responsibility.

(d) Waivers

(i) Prior to submission of a request for a partial or total waiver, Contractor shall speak to Shinay Stewart at shinay.stewart@bpca.ny.gov or (212) 336-9353 for guidance.

(ii) In accordance with 9 NYCRR § 252.2(m), a Contractor that is able to document good faith efforts to meet the goal requirements, as set forth in Section 26.2(e) below, may submit a request for a partial or total waiver on Form SDVOB 200 (https://ogs.ny.gov/Veterans/Docs/2016/SDVOB_200_Waiver_Form.docx), accompanied by supporting documentation. Contractor may submit the request for waiver at the same time it submits its SDVOB Utilization Plan. If a request for waiver is submitted with the SDVOB Utilization Plan and is not accepted by Owner at that time, the provisions of Section 26.2(c)(iii), (iv) and (v) will apply. If the documentation included with the Contractor's waiver request is complete, Owner shall evaluate the request and issue a written notice of acceptance or denial within 20 days of receipt.

(iii) Contractor shall attempt to utilize, in good faith, the SDVOBs identified within its SDVOB Utilization Plan, during the performance of the Work. Requests for a partial or total waiver of established goal requirements made subsequent to award of the Agreement may be made at any time during the term of the Agreement to Owner, but must be made no later than prior to the submission of a request for final payment.

(iv) If Owner, upon review of the SDVOB Utilization Plan and Monthly SDVOB Compliance Report determines that Contractor is failing or refusing to comply with the contract goals and no waiver has been issued in regards to such non-compliance, Owner may issue a notice of deficiency to the Contractor. The Contractor must respond to the notice of deficiency within seven business days of receipt. Such response may include a request for partial or total waiver of SDVOB contract goals. Waiver requests should be sent to Owner.

(e) Required Good Faith Efforts. In accordance with 9 NYCRR § 252.2(n), Contractors must document their good faith efforts toward utilizing SDVOBs on the Agreement. Evidence of required good faith efforts shall include, but not be limited to, the following:

(i) Copies of solicitations to SDVOBs and any responses thereto.

(ii) Explanation of the specific reasons each SDVOB that responded to Contractors' solicitation was not selected.

(iii) Dates of any pre-bid, pre-award or other meetings attended by Contractor, if any, scheduled by Owner with certified SDVOBs whom Owner determined were capable of fulfilling the SDVOB goals set in the Agreement.

(iv) Information describing the specific steps undertaken to reasonably structure the Work for the purpose of subcontracting with, or obtaining supplies from, certified SDVOBs.

(v) Other information deemed relevant to the waiver request.

(f) Monthly SDVOB Contractor Compliance Report

In accordance with 9 NYCRR § 252.2(q), Contractor is required to report Monthly SDVOB Contractor Compliance to Owner during the term of the Agreement for the preceding month's activity, documenting progress made towards achieving the SDVOB goals. This information must be submitted using form SDVOB 101 available at https://ogs.ny.gov/Veterans/Docs/2016/SDVOB_101_Monthly_Compliance%20Report.docx and should be completed by the Contractor and submitted to Owner, by the 10th day of each month during the term of the Contract, for the preceding month's activity to: Shinay Stewart at shinay.stewart@bpca.ny.gov.

(g) Breach of Contract and Damages

In accordance with 9 NYCRR § 252.2(s), any Contractor found to have willfully and intentionally failed to comply with the SDVOB participation goals set forth in this Agreement, shall be found to have breached the Agreement and Contractor shall pay damages as set forth therein.

ARTICLE 27 - STANDARD PROVISIONS

27.1 Provision Required by Law Deemed Inserted

Each and every provision of law and governmental regulation required by law to be inserted in the Contract Documents shall be deemed to be inserted therein and this Agreement shall read and shall be enforced as though so included therein, and if through mistake or otherwise any such provision is not inserted, or is not correctly inserted, then upon the application of either party, this Agreement shall be deemed to be amended to make such insertion or correction. If this Agreement contains any unlawful provision, the same shall be deemed of no effect and shall, upon the application of either party, be deemed stricken from this Agreement without affecting the binding force of the remainder.

27.2 Compliance with Laws, Rules and Regulations

Contractor and each Subcontractor and Materialman shall comply fully with all applicable laws, rules and regulations pertaining to the Project and the Work.

27.3 Applicable Law, Forum and Jurisdiction

This Agreement shall be governed by the laws of the State of New York. All actions or proceedings relating, directly or indirectly, to this Agreement shall be litigated only in courts located within the County of New York. Contractor, any guarantor of the performance of its obligations hereunder (including sureties for Payment and Performance Bonds) (“**Guarantor**”) and their successors and assigns hereby subject themselves to the jurisdiction of any state or federal

court located within such county, waive the personal service of any process upon them in any action or proceeding therein and consent that such process be served by certified or registered mail, return receipt requested, directed to the Contractor and any successor at Contractor's address hereinabove set forth, to Guarantor and any successor at the address set forth in the instrument of guaranty and to any assignee at the address set forth in the instrument of assignment. Such service shall be deemed made as of the date of the return receipt.

27.4 No Third Party Rights

Nothing in this Agreement shall create or shall give to third parties any claim or right of action against BPCA, Construction Manager, or Architect beyond such as may legally exist irrespective of this Agreement.

27.5 Exculpation; Limitation of Liability

In no event shall any claim be asserted under this Agreement by Contractor or any Subcontractor or Materialman against any member, officer, employee, lessee, Contractor or agent of BPCA, Construction Manager, or Architect. By execution of this Agreement, Contractor agrees to look solely to BPCA with respect to any claim which may arise. It is hereby understood by and between the parties hereto that BPCA shall only be liable to the extent of monies available to BPCA.

27.6 Protection of Lives and Health

(a) Contractor's, Subcontractor's and Materialman's attention is specifically called to the rules and regulations, codes and bulletins of the New York State Department of Labor. Attention is also directed to the standards imposed under the Federal Occupational Safety and Health Act of 1970, as amended.

(b) Contractor shall maintain an accurate record of all cases of death, occupational disease, and injury requiring medical attention or causing loss of time from work, arising out of and in the course of employment on work under this Agreement, and shall immediately notify BPCA in writing of any injury which results in hospitalization or death. Contractor shall also complete and submit to BPCA the "Incident Report Form" attached hereto and made a part hereof as Exhibit F within 48 hours of the occurrence of any such injury.

(c) Contractor alone shall be responsible for the safety, efficiency and adequacy of contractor's work, plant, appliances and methods, and for any damage that may result from the failure, or the improper construction, maintenance, or operation of such work, plant, appliances and methods.

27.7 Waiver of Immunity Clause

Contractor hereby agrees to the provisions of New York Public Authorities Law Section 2875, which require that a person, when called before a grand jury, head of a State department, temporary State commission, or other State agency, the Organized Crime Task Force in the State Department of Law, head of a department or other City agency, which is empowered to compel the attendance of witnesses and examine them under oath, to testify in an investigation concerning

any transaction or contract had with the State, any political subdivision thereof, or with any public department, agency or official of the State, a public authority or with any public department, agency or official of the State or of any political subdivision thereof or of a public authority, that person must sign a waiver of immunity against subsequent criminal prosecution or to answer any relevant questions concerning such transaction or contract. Upon the refusal of any person to comply with such provisions:

(a) such person, and any firm, partnership or corporation of which such person is a member, partner, director or officer shall be disqualified from thereafter selling to or submitting bids to or receiving awards from or entering into any contracts with any public authority or official thereof, for goods, work or services, for a period of five (5) years after such refusal; and

(b) any and all contracts made with any public authority or official thereof, by such person, and by any firm, partnership or corporation of which such person is a member, partner, director or officer may be canceled or terminated by the public authority without incurring any penalty or damages on account of such cancellation or termination, but any monies owing by the public authority for goods delivered or work done prior to the cancellation or termination shall be paid.

27.8 Prohibited Interests

No official of BPCA who is authorized in such capacity and on behalf of BPCA to negotiate, make, accept, or approve, or take part in negotiating, making, accepting, or approving any Architectural, Engineering, inspection, Purchase Order or any Subcontract in connection with the Work, shall become directly or indirectly interested personally in the Agreement. Contractor is advised that no official or employee of BPCA is permitted to indirectly solicit, accept, or receive gifts whether in the form of money, service, loan, travel, entertainment, hospitality, thing or promise, or in any other form. No officer, employee, architect, attorney, engineer, inspector or Contractor of or for BPCA who is authorized in such capacity and on behalf of BPCA to exercise any legislative, executive, supervisory or other similar functions in connection with the Work, shall become directly or indirectly interested personally in the Agreement, any Purchase Order, Subcontract, insurance contract, or any other contract pertaining to the Work.

27.9 Labor Provisions

(a) It is hereby agreed that all applicable provision of the Labor Law of the State of New York shall be carried out in the performance of the Work.

(b) Contractor specifically agrees, as required by New York Labor Law Sections 220 and 220-d as amended, that:

(1) no laborer, workman or mechanic, in the employ of Contractor, Subcontractor, Materialman or other person doing or contracting to do the whole or any part of the Work contemplated by the Contract Documents shall be permitted or required to work more than eight (8) hours in any one calendar day or more than five (5) days in any one week, except in the emergencies set forth in the Labor Law.

(2) the wages paid for a legal day's work shall be not less than the prevailing

rate of wages as defined by law;

(3) the minimum hourly rate of wage to be paid shall be not less than that stated in the Contract Documents and as shall be designated by the Industrial Commissioner of the State of New York; and

(4) Contractor shall post at appropriate conspicuous points at the Site, a schedule showing all determined minimum wage rates for the various classes of laborers and mechanics to be engaged in the Work and all deductions, if any, required by law to be made from unpaid wages actually earned by the laborers and mechanics so engaged.

(c) The minimum wage rates, if any, herein specified for apprentices shall apply only to persons working with the tools of the trade which such persons are learning under the direct supervision of journeymen mechanics. Except as otherwise required by law, the number of apprentices in each trade or occupation employed by Contractor or any Subcontractor or Materialman shall not exceed the number permitted by the applicable standards of the New York State Department of Labor, or, in the absence of such standards, the number permitted under the usual practice prevailing between the unions and the employers' association of the respective trades or occupations.

(d) All employees of Contractor and each Subcontractor and Materialman shall be paid in accordance with the provisions of the Labor Law.

(e) Contractor agrees that, in case of underpayment of wages to any worker engaged in the Work by Contractor or any Subcontractor or Materialman, BPCA shall withhold from Contractor out of payments due an amount sufficient to pay such worker the difference between the wages actually paid such worker for the total number of hours worked, and that BPCA may disburse such amount so withheld by BPCA for and on account of Contractor to the employee to whom such amount is due. Contractor further agrees that the amount to be withheld pursuant to this paragraph may be in addition to the percentages to be retained by BPCA pursuant to other provisions of the Contract Documents.

(f) The Labor Law provides that this Agreement may be terminated for cause and no sum paid for any Work done thereunder upon a second conviction for willfully paying less than:

- (1) the stipulated wage scale as set forth in New York Labor Law Section 220, subdivision 3, as amended, or
- (2) less than the stipulated minimum hourly wage scale as specified in Labor Law, Section 220-d, as amended.

(g) Contractor specifically agrees, as required by the New York Labor Law Section 220-e, as amended, that:

(1) in the hiring of employees for the performance of Work under this Agreement or any Subcontract or Purchase Order hereunder, or for the manufacture, sale or distribution of Materials, equipment or supplies hereunder, but limited to operations performed within the territorial limits of the State of New York, no Contractor, Subcontractor, Materialman

or any person acting on behalf of such Contractor or Subcontractor, or Materialman, shall by reason of race, creed, color, sex or national origin discriminate against any citizen of the State of New York who is qualified and available to perform the work to which the employment relates;

(2) no Contractor, Subcontractor, Materialman, or any person on behalf of such Contractor, Subcontractor or Materialman shall, in any manner, discriminate against or intimidate any employee hired for the performance of work under this Agreement on account of race, creed, color, sex or national origin;

(3) there may be deducted from the amount payable to Contractor, by BPCA under this Agreement, a penalty of \$50.00 for each person for each calendar day during which such person was discriminated against or intimidated in violation of the terms of this Agreement; and

(4) this Agreement may be canceled or terminated for cause by BPCA and all monies due or to become due hereunder may be forfeited for a second or any subsequent violation of the terms or conditions of this Section of this Agreement.

(h) Where applicable, Contractor agrees to settle labor disputes in accordance with the provisions of The New York Plan For The Settlement of Jurisdictional Disputes Between The Building And Construction Trades Council Of Greater New York And The Building Trades Employers' Association Of The City of New York.

27.10 Disputes Resolution Procedure

(a) The provisions of this Article shall constitute Contractor's sole means for challenging any determination, order or other act or omission of BPCA or otherwise asserting against BPCA any claim of whatever nature arising under, or in any way relating to, this Agreement (any such challenge or assertion by Contractor being herein referred to as a "**Dispute(s)**"). Exhaustion of these dispute resolution procedures, including the judicial review set forth below, shall be the parties' sole remedy in connection with any Dispute.

(b) The parties to this Agreement hereby authorize and agree to the resolution of all Disputes arising out of, under or in connection with, this Agreement in accordance with the following and pursuant to the procedures set forth in paragraph (c) of this Section 27.10. With respect to any Dispute which relates in whole or primary part to technical issue(s) under this Agreement including, without limitation, determinations as to the acceptability or fitness of any Work, the meaning or interpretation of the Contract Documents, the question of whether any Work falls within the scope of the Specifications set forth in the Contract Documents, the acceptability of any proposed substitutions, modifications or other submissions under this Agreement, the disapproval of proposed Subcontractors or Materialmen (to the extent such disapproval is related to technical issues), the extension of time to the extent related to a technical matter, the question of whether substantial completion or final completion has been achieved, the parties hereby authorize the General Counsel of BPCA, or his/her designee, (hereinafter referred to as the "**Arbiter**"), acting personally, to render a final and binding decision.

(c) All Disputes shall be initiated through a written submission by either party (such submission to be hereinafter referred to as the "**Dispute Notice**") to the Arbiter within ten (10)

days of the determination, order or other act or omission which is the subject of the Dispute. Within ten (10) days after the submission of such Dispute Notice, the party initiating the Dispute shall provide the Arbiter with all evidence and other pertinent information in support of the party's position and/or claim. Within thirty (30) days from the date of the Dispute Notice, the party against whom the Dispute Notice was filed shall submit any and all materials which it deems pertinent to the Arbiter. Upon submission of a Dispute Notice to the Arbiter, the Arbiter shall render its decision in writing and deliver a copy of same to the parties within a reasonable time not to exceed sixty (60) days after the receipt of all materials. In rendering such decision, the Arbiter may seek such technical or other expertise as it shall deem necessary or appropriate (notifying both parties to the Dispute when he/she so seeks such other information or expertise) and seek any such additional oral and/or written argument or materials from either or both parties to the Dispute as he/she deems fit. The Arbiter shall have the discretion to extend the time for submittals required hereunder. The Arbiter's ability to render and the effect of a decision hereunder shall not be impaired or waived by any negotiations or settlement offers in connection with the matter presented, whether or not the Arbiter participated therein, or by any prior decision of others, or by any termination or cancellation of this Agreement. The decision of the Arbiter shall be final and binding on both parties to this Agreement.

(d) It is expressly understood and agreed that the pendency of a Dispute hereunder shall at no time and in no respect constitute a basis for any modification, limitation or suspension of Contractor's obligation to fully perform in accordance with this Agreement and that Contractor shall remain fully obligated to perform the Work notwithstanding the existence of any such Dispute.

27.11 Additional Provisions Relating to the Prosecution of Claims for Money Damages

(a) Except as otherwise provided in this Agreement, if Contractor claims or intends to claim compensation or money damages for any damage or loss sustained by reason of any determination, order or other act or omission of BPCA, Contractor shall furnish a written notice to the Arbiter setting forth the nature of the claim and the extent of the damage sustained within ten (10) days of the occurrence of such loss or damages. This written notice shall constitute Contractor's submission to the Arbiter for the purposes of requesting the Arbiter's determination in accordance with Section 27.10 above. Any such claim shall state as fully as then possible all information relating thereto and shall be supported by any then available documentation, including daily records showing all costs incurred. Such information shall be supplemented with any and all further information, including information relating to the quantum of losses or damages sustained, as soon as practicable after the information becomes or reasonably should become known to the Contractor.

(b) Any claim for compensation or monetary damages, the successful prosecution of which necessarily depends upon a technical determination favorable to Contractor, may not proceed unless and until Contractor first obtains such a favorable determination with respect to the technical issue and must be made within ten (10) days of such determination; moreover, Contractor must submit to the Arbiter any documentation or proof in support of the monetary claim within fifteen (15) days of such determination in order to proceed with such a claim. This written notice shall constitute Contractor's submission to the Arbiter for the purposes of requesting the Arbiter's determination in accordance with Section 27.10 above.

(c) Compliance with the provisions hereof shall constitute a condition precedent to the Contractor's submission of a Dispute pursuant to Section 27.10 with respect to any claim for compensation or monetary damages and the Contractor shall be deemed to have waived any claim not submitted in accordance herewith.

(d) Any final determination of the Arbiter with respect to a Dispute initiated pursuant to this Article 27 shall be subject to review solely in the form of a challenge following the decision by the Arbiter in a Court of competent jurisdiction of the State of New York, County of New York, under Article 78 of the New York Civil Practice Law and Rules or a United States Court located in New York City under the procedures and laws applicable in that court, it being understood the review of such Court shall be limited to the question of whether or not the Arbiter's determination is arbitrary, capricious or lacks a rational basis. No evidence or information shall be introduced or relied upon in such proceeding which has not been duly presented to the Arbiter in accordance with this Article 27.

27.12 Limitation on Actions

(a) Subject to the provisions of Section 27.11, no action or proceeding shall lie or shall be maintained by Contractor against BPCA, Construction Manager, or Architect unless (i) such action or proceeding shall be commenced within six (6) months of the date of the issuance of the Certificate of Substantial Completion to Contractor; or (ii) in the case of an action or proceeding for monies due pursuant to Section 5.7 hereof, or arising exclusively from or pertaining exclusively to work performed after the date of issuance of the Certificate of Substantial Completion, unless such action or proceeding is commenced no later than six (6) months after the issuance of the certificate of final completion to Contractor; or (iii) if this Agreement is terminated by BPCA prior to the issuance of the Certificate of Substantial Completion, unless such action or proceeding is commenced within six (6) months after the date of such termination.

(b) Nothing in this Section 27.12 shall be construed to modify or lengthen a shorter limitations period provided by applicable law.

(c) No action or proceeding shall be commenced by Contractor against BPCA, Construction Manager, or Architect except in the Supreme Court of the State of New York, County of New York.

(d) Nothing in this Section 27.12 shall be construed to suggest that Contractor, under any circumstances, may bring an action or proceeding against Construction Manager, or Architect.

27.13 Waiver of Remedies

Contractor acknowledges that it can be compensated adequately by money damages for any breach of this Agreement which may be committed by BPCA, Construction Manager, or Architect. Contractor agrees that no default, act or omission of BPCA, Construction Manager, or Architect shall constitute a material breach of contract entitling Contractor to cancel or rescind this Agreement or to suspend or abandon performance thereof, other than the failure of BPCA to make a payment of the Contract Price in accordance with the terms hereof solely because sufficient funds to pay the Contract Price have not been appropriated or will otherwise not be made available to BPCA. Contractor hereby waives any and all rights and remedies to which Contractor might

otherwise be or become entitled to because of any wrongful act or omission of BPCA, Construction Manager, or Architect except as provided in this Section 27.13 and Contractor's right to money damages.

27.14 Modification of Agreement

No change in or modification, termination or discharge of this Agreement in any form whatsoever shall be valid or enforceable unless it is in writing and signed by the party to be charged therewith or its duly authorized representative, provided, however, that any change in or modification, termination or discharge of this Agreement expressly provided for in this Agreement shall be effective as so provided.

27.15 Signs and Parking

Contractor agrees that it shall not display on or about the Site any sign, trademark or other advertisement without the approval of BPCA and Construction Manager. Contractor shall not and shall not permit any of its Subcontractors or Materialmen to park any vehicles on the Site.

27.16 Entire Agreement

The Contract Documents constitute the entire Agreement between the parties and incorporate all prior understandings in connection with the subject matter hereof.

27.17 Rights and Remedies

The duties and obligations imposed by the Contract Documents and the rights and remedies available thereunder shall be in addition to and not a limitation of any duties, obligations, rights and remedies otherwise imposed or available by law. No action or failure to act by BPCA, Construction Manager, or Architect or Contractor including, but not limited to, the making of any payment or permitting Contractor to continue with the performance of the Work shall constitute a waiver of any right or duty afforded any of them under this Agreement, nor shall any such action or failure to act constitute an approval of or acquiescence in any breach thereunder, except as may be specifically agreed in writing.

27.18 Participation in International Boycott Prohibited

Contractor agrees, as a material condition of this Agreement, that neither Contractor nor any substantially owned or affiliated person, firm, partnership or corporation has participated or is participating or shall participate in an international boycott in violation of the provisions of the United States Export Administration Act of 1969, as amended, or the United States Export Administration Act of 1979, as amended, or the Regulations of the United States Department of Commerce promulgated thereunder. This Agreement shall be rendered forfeit and void by the Comptroller of the State of New York if, subsequent to execution, such person, firm, partnership or corporation has been convicted of a violation of the provisions of either of such federal acts or such Regulations or has been found upon the final determination of the United States Commerce Department or any other appropriate agency of the United States to have violated the provisions of either of such federal acts or such Regulations.

27.19 Compliance with “Buy-American” Statutes

Contractor and any substantially owned or affiliated person, firm, partnership or corporation agrees to comply with the New York Public Authorities Law, Section 2603-A as amended (affects steel or steel products).

27.20 Permitted Successors

References to parties and entities herein shall be deemed to include their permitted successors.

27.21 MacBride Fair Employment Principles

If the amount payable to Contractor under this Agreement is greater than \$15,000, Contractor hereby certifies that it and/or any individual or legal entity in which it holds a 10% or greater ownership interest, and any individual or legal entity that holds a 10% or greater ownership interest in it, either have no business operations in Northern Ireland; or shall take lawful steps in good faith to conduct any business operations they have in Northern Ireland in accordance with the MacBride Fair Employment Principles relating to nondiscrimination in employment and freedom of workplace opportunity regarding such operations in Northern Ireland, as set forth in New York State Finance Law Article XI Section 165(5), and shall permit independent monitoring of their compliance with such Principles.

27.22 Iran Divestment Act

By signing this Agreement, each person and each person signing on behalf of any other party certifies, and in the case of a joint bid or partnership each party thereto certifies as to its own organization, under penalty of perjury, that to the best of its knowledge and belief that each person is not on the list created pursuant to paragraph (b) of subdivision 3 of Section 165-a of the State Finance Law.

27.23 Termination for Failure to Disclose Under State Finance Law §139k

BPCA reserves the right to terminate this Agreement in the event it is found that the certification filed by Contractor pursuant to New York State Finance Law §139-k was intentionally false or intentionally incomplete. Upon such finding, BPCA may exercise its termination right by providing written notification to the Contractor in accordance with the written notification terms of this contract. If a contract is terminated in accordance with State Finance Law §139k(5), BPCA, its subsidiaries and affiliates, will include a statement in BPCA’s procurement record describing the basis for any action taken under the termination provision.

27.24 Labor Peace

The Contractor and its Subcontractors and Materialmen shall not employ on the Work any labor, materials or means whose employment, or utilization during the course of this Agreement, may tend to or in any way cause or result in strikes, Work stoppages, delays, suspension of Work or similar troubles by workers employed by the Contractor or its Subcontractors, Materialmen, or by any of the trades working in or about the buildings and premises where Work is being performed

under this Agreement, or by other contractors or their subcontractors pursuant to other agreements, or on any other building or premises owned or operated by BPCA, its contractors or affiliates. Any violation by the Contractor of this requirement may be considered as proper and sufficient cause for declaring the Contractor to be in default, and for BPCA to take action against Contractor as set forth in Article 15 of this Agreement, or such other Section of this Agreement as BPCA may deem proper.

27.25 Comptroller's Approval

If this Agreement is considered an "eligible contract," as defined by New York Code, Rules and Regulations Title 2 Part 206.2, it is subject to the New York State Comptroller's approval, and therefore shall not be valid and enforceable until that approval has been obtained. A contract is considered an "eligible contract," as defined by Title 2 of NYCRR Part 206.2, if it is not a specifically exempt contract, is executed by a state authority on or after March 1, 2010, the aggregate consideration under the contract may reasonably be valued in excess of one million dollars (including all reasonably anticipated renewals and amendments), AND the contract (A) was or shall be awarded on a single-source basis, sole-source basis or pursuant to any other method of procurement that is not a competitive procurement OR (B) shall be paid in whole or in part with monies appropriated by the State, either directly to a state authority or to a state agency that pays the money to a state authority.

27.26 Key Person/Personnel

The parties understand that in entering into this Agreement, BPCA has relied upon Contractor's representation that [name(s) and title(s)] (hereinafter the "**Key Personnel**") will be directly and consistently involved in supervising the Work and actively engaged in the day-to-day management of the Work, which shall include attending mandatory Project meetings. If the Key Personnel is/are not available as described herein, or if the Key Personnel depart from the firm or severs his/her/their relationship with the Contractor, or for whatever other reason is/are not available to work on the Project, then BPCA shall have the right to terminate this Agreement. The parties also agree that at any time during the course of the Work, BPCA may designate additional or substitute key personnel to perform the Work. Contractor agrees to make the additional or substituted key personnel available under the same conditions set forth herein.

27.27 Form of Agreement Not an Offer

Notwithstanding anything herein to the contrary, the submission of this form of Agreement by BPCA to Contractor shall not constitute an offer, and execution hereof by Contractor shall not be considered acceptance of an offer. A binding contract between the parties shall exist only if and at such time as both parties have executed this Agreement.

27.28 General Responsibility

(a) The Contractor shall at all times during the Agreement term remain responsible. The Contractor agrees, if requested by BPCA or its designee, to present evidence of Contractor's continuing legal authority to do business in New York State, integrity, experience, ability, prior performance, and organizational and financial capacity.

(b) BPCA or its designee, in its sole discretion, reserves the right to suspend any or all activities under this Agreement, at any time, when BPCA discovers information that calls into question the responsibility of Contractor. In the event of such suspension, Contractor will be given written notice outlining the particulars of such suspension. Upon issuance of such notice, Contractor must comply with the terms of the suspension order. Activity under the Agreement may resume at such time as BPCA or its designee issues a written notice authorizing a resumption of performance under the Agreement.

(c) Upon written notice to the Contractor, and a reasonable opportunity to be heard with appropriate BPCA officials or staff, the Agreement may be terminated by BPCA or its designee at Contractor's expense where Contractor is determined by BPCA or its designee to be nonresponsible. In such event, BPCA or its designee may complete the contractual requirements in any manner BPCA may deem advisable and pursue available legal or equitable remedies for breach.

27.29. Counterparts

This Agreement may be executed in any number of counterparts, all of which taken together shall constitute one instrument, but the Agreement shall not be deemed effective unless signed by all parties.

27.30. Section Headings

Section headings contained in this Agreement are for convenience only and shall not be considered for any purpose in governing, limiting, modifying, construing or affecting the provisions of this Agreement and shall not otherwise be given legal effect.

27.31. Subordination of Terms in the Exhibits

In the event of a conflict of terms, the terms stated in Sections 1-27 herein, shall take precedence over and shall prevail over any printed, typed, or handwritten terms located in the Exhibits.

SIGNATURE PAGE FOLLOWS

IN WITNESS WHEREOF, the parties hereto have executed this Agreement, as of the date first above written.

BATTERY PARK CITY AUTHORITY, d/b/a

HUGH L. CAREY BATTERY PARK CITY AUTHORITY

By: _____

Name: _____

Title: _____

[CONTRACTOR NAME]

By: _____

Name: _____

Title: _____

FEIN #

EXHIBIT D

Form of Cost Proposal

Cost Proposal

(Proposer to submit executed Cost Proposal on its letterhead)

Date:

Battery Park City Authority
200 Liberty Street, 24th Floor
New York, New York 10281

Attention: Mr. Michael LaMancusa
Contract Administrator

Dear Mr. LaMancusa:

The undersigned (the "Proposer") hereby proposes to perform the work set forth in Exhibit A ("Scope of Work") attached to the Request for Proposal for **Battery Park City Ballfield & Community Center Resiliency Project: General Contractor Services** (the "RFP"). The Proposer agrees to commence the Work immediately upon execution of the Contract in accordance with the terms stipulated in the following pages, for the lump-sum amount written below.

A. Base Proposal

A total lump sum amount of \$ _____ (_____ Dollars and _____ Cents) to perform all work as described in Exhibit A of this RFP and per the Construction Documents.

B. Bid Breakdown, Unit Prices, and Labor Rates

1. The Proposer has submitted with its Cost Proposal an itemized cost for the Work, according to the Bid Breakdown, attached hereto as Exhibit E. The total sum of these items should be equivalent to the Base Proposal.
2. Enclosed with its Cost Proposal, Proposer has submitted a completed Form of Labor Rates (Exhibit F), showing labor rates for all trades, including all costs except overhead and profit. Prices shown include base hourly rates, overtime rates, insurance and benefits.
3. Enclosed with its Cost Proposal, Proposer has submitted a completed Form of Unit Pricing (Exhibit G) as an aid in the evaluation of the reasonableness of Proposer's lump-sum Cost Proposal and to apply to future change order work, if any.

Name of Proposer:

By: _____

Title: _____

EXHIBIT E

Form of Bid Breakdown

<u>Project Component</u>	<u>Total Cost</u>
Mobilization/demobilization including temporary fencing and barricades, general conditions, and permits	\$ _____
Remove and discard existing concrete sidewalk, paving, curb, and subbase	\$ _____
Remove, salvage, and reinstall existing concrete barriers. (Salvaged materials to be stored by contractor.)	\$ _____
Remove existing pavers and subbase. Salvage pavers for reuse	\$ _____
Provide protective tree guards at fifteen (15) trees	\$ _____
Remove ten (10) trees including stumps and roots.	\$ _____
Excavate, form, install steel reinforcing, and place concrete for grade beam at the base of the existing metal fencing.	\$ _____
Furnish/fabricate and install panels atop the concrete grade beam and welded/clipped to existing metal fence posts.	\$ _____
Fabricate/furnish and install decorative aluminum panels to new structural steel panels	\$ _____
Cast-in-place 12-inch-thick, 6-foot-high reinforced concrete wall and footing at southeast corner of Project Site	\$ _____
Furnish and install 2 flood gates	\$ _____
Furnish and install new trees and miscellaneous plantings	\$ _____

EXHIBIT F

Form of Labor Rates

The following rates are to include base wages, benefits, taxes, insurance, and payroll costs complete. Overhead and profit are not to be included.

Project Manager - per hour	\$ _____	O/T \$ _____
Superintendent - per hour	\$ _____	O/T \$ _____
Mason - per hour	\$ _____	O/T \$ _____
Welder - per hour	\$ _____	O/T \$ _____
Carpenter - per hour	\$ _____	O/T \$ _____
Laborer - per hour	\$ _____	O/T \$ _____
Plumber - per hour	\$ _____	O/T \$ _____
Iron worker – per hour	\$ _____	O/T \$ _____
Operating Engineer	\$ _____	O/T \$ _____

EXHIBIT G

Form of Unit Pricing

Unit Cost

1" thick steel plating -	\$_____sq ft
Aluminum decorative panel	\$_____sq ft
Concrete	\$_____cu td
Trees 4" – 4.5" caliper	\$_____ea
Vines 1 gallon	\$_____ea
Replacement wire mesh panel	\$_____ea
Pavers at West Street sidewalk	\$_____sq ft

EXHIBIT H

Drawings & Specifications

[NO FURTHER TEXT ON THIS PAGE]

**THE CITY OF NEW YORK
BATTERY PARK CITY AUTHORITY**

**BATTERY PARK CITY BALLFIELD AND COMMUNITY CENTER
RESILIENCY DESIGN**

**BALLFIELD AND COMMUNITY CENTER FLOOD PROTECTION
CONTRACT NO. 18-2624**

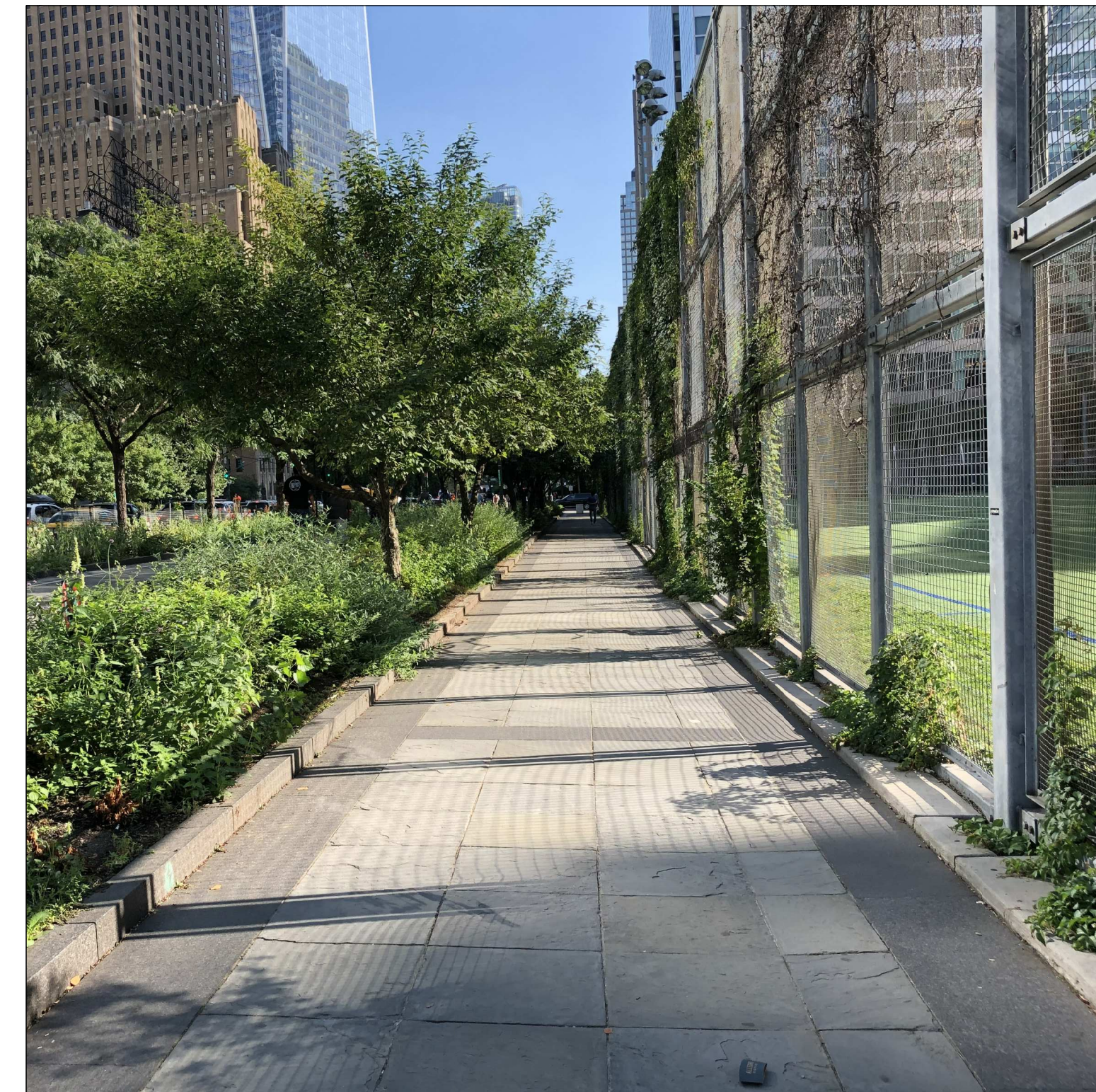
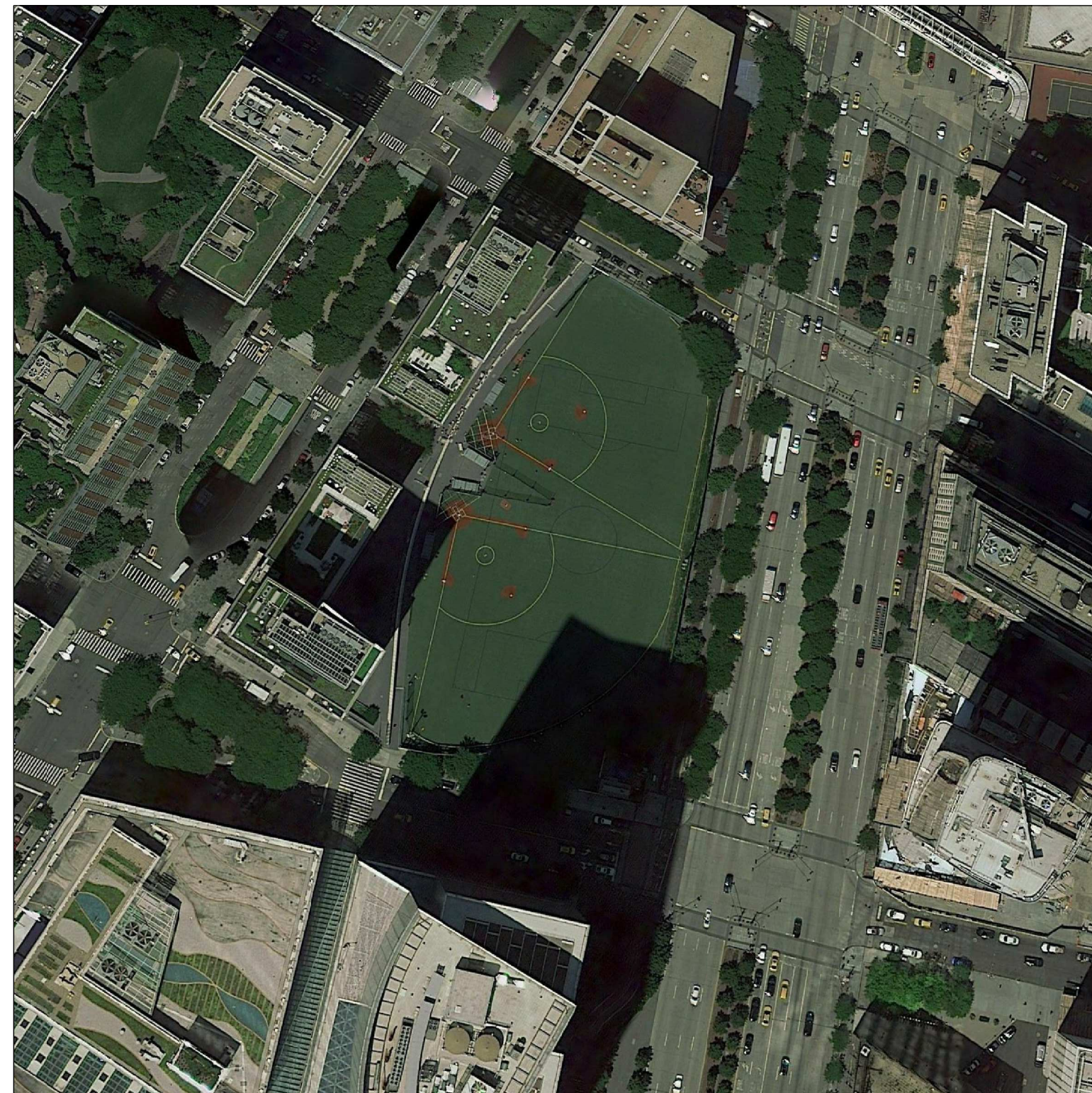



STV INCORPORATED
225 PARK AVENUE SOUTH
5TH FLOOR
NEW YORK, NY 10003
www.stvinc.com

CONSULTANTS



150 WEST 28TH STREET
SUITE 605
NEW YORK, NY 10001
www.siteworkscm.com

SEALS

PROJECT IDENTIFICATION



Battery Park
City Authority

BATTERY PARK CITY
BALLFIELD AND COMMUNITY
CENTER

MARK	DATE	DESCRIPTION	BY
C	11/01/19	ISSUE FOR BID - 95%	AC
B	10/18/19	75% DESIGN SUBMITTAL	AC
A	09/06/19	50% DESIGN SUBMITTAL	AC

ISSUE BLOCK

PROJECT NO.: 3019666
DESIGNED BY: NT
DRAWN BY: NT
CHECKED BY: AC
APPROVED BY: AC
COPYRIGHT: STV, INC

SHEET TITLE

DRAWING LIST

G-001

GENERAL

SHEET NO.	DWG NO.	TITLE
1	G-000	COVER SHEET
2	G-001	DRAWING LIST
3	G-002	FLOOD COMPLIANCE MAP
	G-003	TREE PROTECTION PLAN

CIVIL

SHEET NO.	DWG NO.	TITLE
4	C-001	CIVIL GENERAL NOTES
5	C-002	CIVIL LEGEND AND ABBREVIATIONS
6	C-101	EXISTING CONDITIONS - STREET LEVEL PLAN
7	C-102	EXISTING CONDITIONS - UTILITY PLAN
8	C-103	SITE DEMOLITION PLAN - SHEET 1 OF 2
9	C-104	SITE DEMOLITION PLAN - SHEET 2 OF 2
10	C-111	SITE LAYOUT PLAN - SHEET 1 OF 2
11	C-112	SITE LAYOUT PLAN - SHEET 2 OF 2
12	C-121	SITE GRADING, DRAINAGE, AND UTILITY PLAN - SHEET 1 OF 2
13	C-122	SITE GRADING, DRAINAGE, AND UTILITY PLAN - SHEET 2 OF 2
14	C-131	SOIL EROSION AND SEDIMENT CONTROL PLAN - SHEET 1 OF 2
15	C-132	SOIL EROSION AND SEDIMENT CONTROL PLAN - SHEET 1 OF 2
16	C-501	SITE AND UTILITY DETAILS
17	C-502	SOIL EROSION AND SEDIMENT CONTROL DETAILS

LANDSCAPE ARCHITECTURE

SHEET NO.	DWG NO.	TITLE
18	LA-100	SITE PLAN
19	LA-101	FENCE PANEL ELEVATION
20	LA-102	FENCE PANEL ELEVATION
21	LA-103	FENCE PANEL ELEVATION
22	LA-104	FENCE PANEL ELEVATION
23	LA-105	FENCE PANEL ELEVATION
24	LA-106	FENCE PANEL ELEVATION
25	LA-107	FENCE PANEL ELEVATION
26	LA-108	FENCE PANEL ELEVATION
27	LA-109	PLANTING PLAN
28	LA-110	PLANTING PLAN
29	LA-501	ARCHITECTURAL PANEL DETAILS- A
30	LA-502	ARCHITECTURAL PANEL DETAILS- B
31	LA-503	ARCHITECTURAL PANEL ENLARGEMENTS
32	LA-504	TREE PROTECTION DETAILS
33	LA-505	PLANTING DETAILS

STRUCTURAL

SHEET NO.	DWG NO.	TITLE
34	S-001	STRUCTURAL NOTES SHEET 1 OF 3
35	S-002	STRUCTURAL NOTES SHEET 2 OF 3
36	S-003	STRUCTURAL NOTES SHEET 3 OF 3
37	S-101	PERIMETER PLAN SHEET 1 OF 4
38	S-102	PERIMETER PLAN SHEET 2 OF 4
39	S-103	PERIMETER PLAN SHEET 3 OF 4
40	S-104	PERIMETER PLAN SHEET 4 OF 4
41	S-501	STEEL PLATE WALL SECTIONS AND DETAILS
42	S-502	RETAINING WALL SECTIONS AND DETAILS
43	S-503	CONCRETE WALL SECTIONS AND DETAILS
44	S-504	CONCRETE DETAILS
45	S-505	TYPICAL UTILITY CROSSING DETAILS
46	S-506	WALL SECTIONS AT GATES
47	S-507	PLAN DETAILS AT GATES
48	S-510	STACKABLE FLOOD BARRIER SHEET 1 OF 4
49	S-511	STACKABLE FLOOD BARRIER SHEET 2 OF 4
50	S-512	STACKABLE FLOOD BARRIER SHEET 3 OF 4
51	S-513	STACKABLE FLOOD BARRIER SHEET 4 OF 4

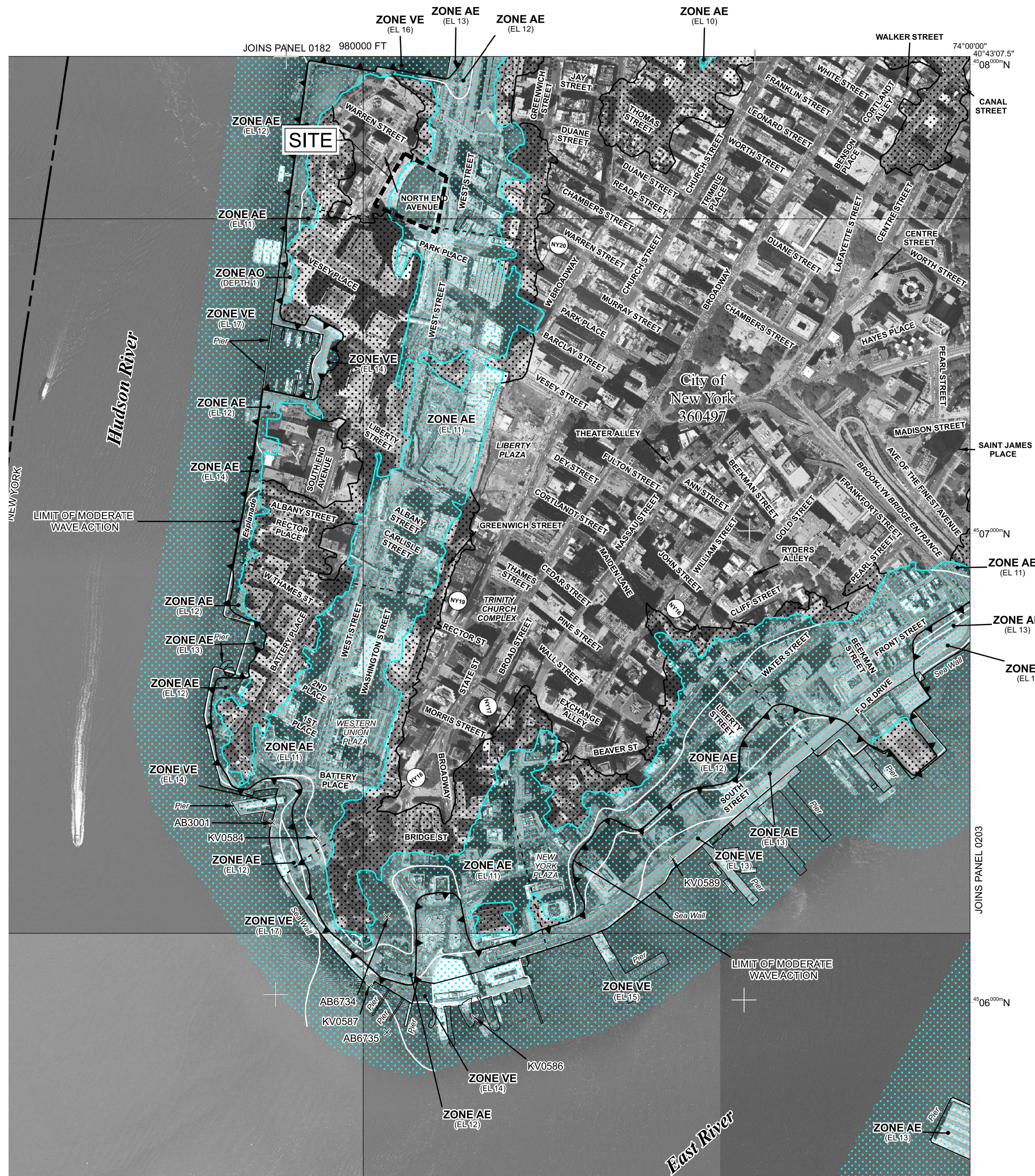

NFIP PANEL 0184G

FIRM
FLOOD INSURANCE RATE MAP

CITY OF
NEW YORK
NEW YORK
BRONX, RICHMOND, NEW YORK,
QUEENS, AND KINGS COUNTIES

PANEL 184 OF 457
(SEE MAP INDEX FOR FIRM PANEL LAYOUT)

CONTAINS:
COMMUNITY NUMBER PANEL SUFFIX
NEW YORK, CITY OF 360497 0184 G

PRELIMINARY
DECEMBER 5, 2013

Notice to User: The Map Number shown below should be used when placing map orders; the Community Number shown above should be used on insurance applications for the subject community.

MAP NUMBER
3604970184G

MAP REVISED

Federal Emergency Management Agency

LEGEND

SPECIAL FLOOD HAZARD AREAS SUBJECT TO INUNDATION BY THE 1% ANNUAL CHANCE FLOOD

The 1% annual flood (100-year flood), also known as the base flood, is the flood that has a 1% chance of being equaled or exceeded in any given year. The Special Flood Hazard Area is the area subject to flooding by the 1% annual chance flood. Areas of Special Flood Hazard include Zones A, AE, AH, AO, AR, A99, V, and VE. The Base Flood Elevation is the water-surface elevation of the 1% annual chance flood.

ZONE A No Base Flood Elevations determined.
ZONE AE Base Flood Elevations determined.
ZONE AH Flood depths of 1 to 3 feet (usually areas of ponding); Base Flood Elevations determined.
ZONE AO Flood depths of 1 to 3 feet (usually sheet flow on sloping terrain); average depths determined. For areas of alluvial fan flooding, velocities also determined.
ZONE AR Special Flood Hazard Area formerly protected from the 1% annual chance flood by a flood control system that was subsequently identified. Zone AR indicates that the former flood control system is being restored to provide protection from the 1% annual chance or greater flood.
ZONE A99 Area to be protected from 1% annual chance flood by a Federal flood protection system under construction; no Base Flood Elevations determined.
ZONE V Coastal flood zone with velocity hazard (wave action); no Base Flood Elevations determined.
ZONE VE Coastal flood zone with velocity hazard (wave action); Base Flood Elevations determined.

FLOODWAY AREAS IN ZONE AE

The floodway is the channel of a stream plus any adjacent floodplain areas that must be kept free of encroachment so that the 1% annual chance flood can be carried without substantial increases in flood heights.

OTHER FLOOD AREAS

ZONE X Areas of 0.2% annual chance flood; areas of 1% annual chance flood with average depths of less than 1 foot or with drainage areas less than 1 square mile; and areas protected by levees from 1% annual chance flood.

OTHER AREAS

ZONE X Areas determined to be outside the 0.2% annual chance floodplain.
ZONE D Areas in which flood hazards are undetermined, but possible.

COASTAL BARRIER RESOURCES SYSTEM (CBRS) AREAS
OTHERWISE PROTECTED AREAS (OPAs)

CBRS areas and OPAs are normally located within or adjacent to Special Flood Hazard Areas.

- 1% annual chance floodplain boundary
- 0.2% annual chance floodplain boundary
- Floodway boundary
- Zone D boundary
- CBRS and OPA boundary
- Boundary dividing Special Flood Hazard Area Zones and boundary dividing Special Flood Hazard Areas of different Base Flood Elevations, flood depths or flood velocities.
- Limit of Moderate Wave Action
- Base Flood Elevation line and value; elevation in feet* (EL 987)
- Base Flood Elevation value where uniform within zone; elevation in feet*

* Referenced to the North American Vertical Datum of 1988

- Cross section line
- Traverse line
- Culvert, Flume, Penstock or Aqueduct
- Road or Railroad Bridge
- Footbridge

Geographic coordinates referenced to the North American Datum of 1983 (NAD 83), Western Hemisphere

1000-meter Universal Transverse Mercator grid values, zone 18

600000 FT 5000-foot grid values: New York State Plane coordinate system, Long Island zone (FIPSZONE 3104), Lambert Conformal Conic projection

Bench mark (see explanation in Notes to Users section of this FIRM panel)

- M 1.5 River Mile

MAP REPOSITORY
Refer to listing of Map Repositories on Map Index

INITIAL NFIP MAP DATE
June 28, 1974

FLOOD HAZARD BOUNDARY MAP REVISIONS
June 11, 1976

FLOOD INSURANCE RATE MAP EFFECTIVE
November 16, 1983

FLOOD INSURANCE RATE MAP REVISIONS

For descriptions of revisions see Notice to Users page in the Flood Insurance Study report.

To determine if flood insurance is available in this community, contact your Insurance agent or call the National Flood Insurance Program at 1-800-638-6620.

MAP SCALE 1" = 500'

250 0 500 1000 FEET
150 0 150 300 METERS

STV 100 Years

STV INCORPORATED
225 PARK AVENUE SOUTH
5TH FLOOR
NEW YORK, NY 10003
www.stvinc.com

CONSULTANTS

SITWORKS
LANDSCAPE ARCHITECTURE, LLC
150 WEST 28TH STREET
SUITE 605
NEW YORK, NY 10001
www.sitworks.com

SEALS

PROJECT IDENTIFICATION

NEW YORK STATE OF OPPORTUNITY **Battery Park City Authority**

**BATTERY PARK CITY
BALLFIELD AND COMMUNITY
CENTER**

MARK	DATE	DESCRIPTION	BY
C	11/01/19	ISSUE FOR BID - 95%	SB
B	10/18/19	75% DESIGN SUBMITTAL	SB
A	09/06/19	50% DESIGN SUBMITTAL	SB

ISSUE BLOCK

PROJECT NO.: 3019666
DESIGNED BY: JA
DRAWN BY: JA
CHECKED BY: SB
APPROVED BY: SB
COPYRIGHT: STV, INC

SHEET TITLE

**FLOOD
COMPLIANCE
MAP**

G-002

TREE PROTECTION NOTES

1. IT IS THE CONTRACTOR'S RESPONSIBILITY TO CHECK AND VERIFY ALL SITE CONDITIONS, BOTH ABOVE AND BELOW THE SURFACE, PRIOR TO COMMENCING WORK. ANY DISCREPANCIES BETWEEN INFORMATION SHOWN ON THE DRAWINGS AND ACTUAL FIELD CONDITIONS SHOULD BE BROUGHT TO THE ATTENTION OF THE ENGINEER IN WRITING, PRIOR TO THE COMMENCEMENT OF WORK.
2. CONSTRUCTION ACCESS ROUTE IS DIAGRAMMATIC. FINAL ROUTE SHALL BE ESTABLISHED ON SITE AND APPROVED BY THE RESIDENT ENGINEER. THE CONSTRUCTION ROUTE PROPOSED BY THE CONTRACTOR SHALL BE REVIEWED BY THE ENGINEER AT LEAST SEVEN DAYS PRIOR TO SITE WORK. ROUTE SHALL BE CONFIRMED ONSITE AND FINAL APPROVED BY THE ENGINEER
3. THE CONTRACTOR SHALL BE RESPONSIBLE FOR COMPLIANCE BY ALL WORKERS AND SUBCONTRACTORS WITH THESE NOTES AND GENERAL CONDITIONS, SPECIAL PROVISIONS, SECTION C, ARTICLE 14 "TREE WORK."
4. THE CONTRACTOR SHALL BE RESPONSIBLE FOR THE PROTECTION AND PRESERVATION OF ALL EXISTING TREES NOT LISTED FOR REMOVAL THAT ARE LOCATED COMPLETELY OR PARTIALLY WITHIN THE CONTRACT LIMIT LINE.
5. THE CONTRACTOR SHALL NOTIFY THE ENGINEER A MINIMUM OF 48 HOURS IN ADVANCE OF ANY WORK ON OR IMPACTING EXISTING TREES, INCLUDING BUT NOT LIMITED TO TREE PROTECTION, PRUNING, TREE REMOVAL, EXCAVATION WITHIN TREE PROTECTION ZONES, DECOMPACTION, TOPSOIL, AND PLANTING WORK. THE ENGINEER SHALL NOTIFY THE APPROPRIATE BOROUGH FORESTER.
6. THE TREE PROTECTION ZONE (TPZ) ALSO CALLED THE CRITICAL ROOT ZONE (CRZ) SHALL BE DEFINED AS THE AREA WITHIN THE DRIP LINE OF EXISTING TREES, UNLESS OTHERWISE SHOWN ON THE TREE PROTECTION PLAN.

7. THE CONTRACTOR SHALL TAKE EXTREME CARE TO PROTECT THE ROOT SYSTEMS OF EXISTING TREES. MATERIAL, EQUIPMENT, OR VEHICLES SHALL NOT BE STOCKPILED OR PARKED WITHIN THE TPZ OF ANY TREE COMPLETELY OR PARTIALLY WITHIN THE CONTRACT LIMIT LINE TO MINIMIZE SURFACE AND SUBSURFACE ROOT AND SOIL COMPACTION.
8. IF STOCKPILING OCCURS WITHIN THE TPZ, A STOP WORK ORDER SHALL BE ISSUED IMMEDIATELY, AND WORK SHALL NOT RE-COMMENCE UNTIL ALL STOCKPILED MATERIAL IS REMOVED FROM THE TPZ AND MITIGATION MEASURES ARE PERFORMED TO THE SATISFACTION OF THE RESIDENT ENGINEER.
9. TEMPORARY WOODEN TREE GUARDS WITH WRAP FOR INDIVIDUAL TREES, TEMPORARY WOODEN TREE GUARD FOR GROVES, AND TEMPORARY SNOW FENCE BOUNDARY SHALL BE MAINTAINED FOR THE DURATION OF THE CONTRACT AND ARE NOT TO BE REMOVED UNTIL DIRECTED BY THE ENGINEER.
10. ALL TREES WITHIN THE CONTRACT LIMIT LINE ARE TO RECEIVE AT LEAST ONE (1) INCH (THE EQUIVALENT OF 750 GALLONS OF WATER PER 1,000 SQUARE FEET OF TREE PROTECTION ZONE) OF WATER PER WEEK BETWEEN THE MONTHS OF MARCH AND OCTOBER. IF RAINWATER IN ANY GIVEN WEEK IS BELOW THIS QUANTITY, THE CONTRACTOR MUST SUPPLEMENT THE AMOUNT RECEIVED BY UTILIZING SOAKER HOSES OR AS DIRECTED BY THE ENGINEER. IF A WATER SOURCE IS UNAVAILABLE AT THE SITE THE CONTRACTOR IS TO PROVIDE IRRIGATION BAGS AND WATER TO APPLY THE REQUISITE WATER AMOUNT.

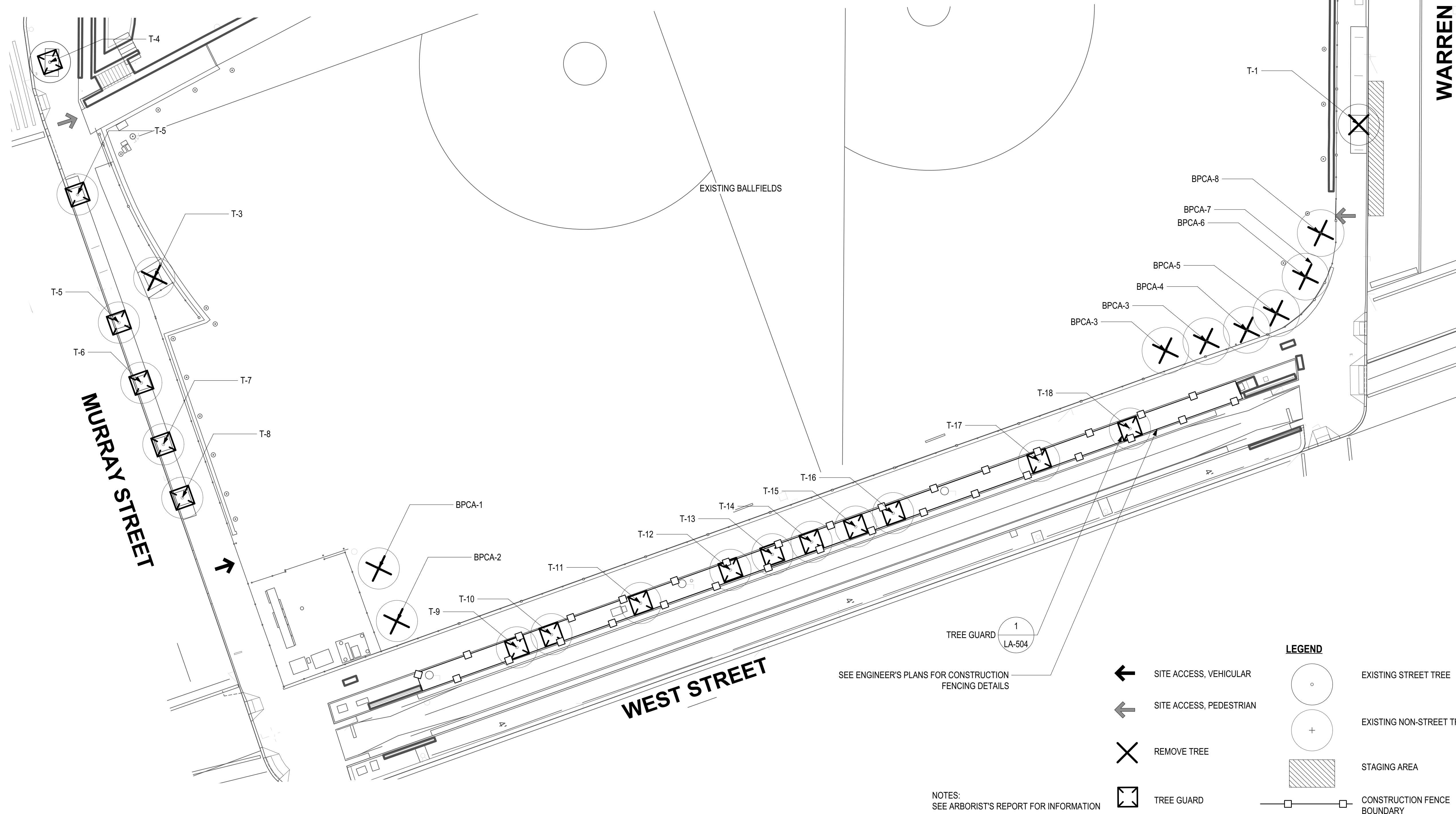

NOTES:
SEE ARBORIST'S REPORT FOR INFORMATION

LEGEND

- ← SITE ACCESS, VEHICULAR
- ← SITE ACCESS, PEDESTRIAN
- ✕ REMOVE TREE
- ◻ TREE GUARD
- EXISTING STREET TREE
- ⊕ EXISTING NON-STREET TREE
- ▨ STAGING AREA
- ◻ CONSTRUCTION FENCE BOUNDARY

STV 100 Years
 STV INCORPORATED
 225 PARK AVENUE SOUTH
 5TH FLOOR
 NEW YORK, NY 10003
 www.stvinc.com

CONSULTANTS

SITWORKS
 LANDSCAPE ARCHITECTURE, LLC

SITWORKS
 150 WEST 28TH STREET
 SUITE 605
 NEW YORK, NY 10001
 www.sitworks.com

SEALS

PROJECT IDENTIFICATION

NEW YORK STATE OF OPPORTUNITY
Battery Park City Authority

BATTERY PARK CITY
 BALLFIELD AND COMMUNITY CENTER

MARK	DATE	DESCRIPTION	BY
C	11/01/19	ISSUED FOR BID - 95%	AW
B	10/18/19	75% DESIGN SUBMITTAL	AW
A	09/06/19	50% DESIGN SUBMITTAL	AW

ISSUE BLOCK

PROJECT NO.:	3019666
DESIGNED BY:	KM
DRAWN BY:	KM
CHECKED BY:	AW
APPROVED BY:	
COPYRIGHT:	STV, INC
SHEET TITLE	

TREE PROTECTION PLAN

G-003

GENERAL CIVIL NOTES

- THIS PLAN IS BASED ON A FIELD SURVEY BY NAIK SURVEYING PERFORMED IN NOVEMBER 2018 AND UPDATED ON APRIL 12, 2019.
- PORTIONS OF THE SURVEY HAVE BEEN REVISED TO REFLECT FIELD CONDITIONS AND/OR RECORD DRAWINGS OBTAINED AFTER THE ISSUANCE OF THE SURVEY INCLUDING: CORRECTION TO THE ROUTE OF THE EXISTING STORM LINES ON THE CORNER OF MURRAY ST AND WEST ST AND CORRECTIONS TO THE SIZES OF EXISTING FENCE POSTS SURROUNDING THE BPCA PROPERTY. THESE CHANGES SHOULD BE VERIFIED IN FIELD BY THE CONTRACTOR.
- THE SITE IS LOCATED WITHIN FLOOD ZONE AE BASED ON THE 2013 FEMA FIRM MAP NO. 3604970184G. THE BASE FLOOD ELEVATION IS 11.0' (NAVD88). SEE G-002 FOR FLOOD MAP.
- THE CONTRACTOR SHALL CONTACT THE VARIOUS UTILITY COMPANIES WITH SERVICE IN THE AREA PRIOR TO EXCAVATING PIPES OR RELATED STRUCTURES UNDER THE PUBLIC SIDEWALK.
- TEMPORARY FENCING OR BARRICADES SHALL BE INSTALLED TO ISOLATE WORK AREAS FROM THE PUBLIC AND ADJACENT BUILDING OCCUPANTS DURING THE WORK OF THIS CONTRACT.
- THE CONTRACTOR SHALL EXAMINE AND VERIFY IN THE FIELD ALL EXISTING AND GIVEN DIMENSIONS WITH THOSE SHOWN ON THE PLANS. IN THE CASE OF DISCREPANCIES, THE CONTRACTOR SHALL IMMEDIATELY NOTIFY THE PROJECT ENGINEER.
- WHERE CONSTRUCTION IS ADJACENT TO EXISTING LINES (FUEL, WATER, TELEPHONE, GAS, ELECTRIC, COMMUNICATION, STORM SEWER, SANITARY SEWER, AND THERMALS) THE CONTRACTOR SHALL HAND EXCAVATE TEST PITS AND LOCATE, MARK AND PROTECT UTILITY LINES AGAINST DISTURBANCE OR DAMAGE.
- ALL ITEMS NOTED FOR DEMOLITION SHALL BE COMPLETELY REMOVED AND LEGALLY DISPOSED.
- IT IS THE SOLE RESPONSIBILITY OF THE CONTRACTOR TO OBTAIN ALL REQUIRED SIDEWALK PERMITS INCLUDING SIDEWALK CLOSURE PERMIT FOR COMPLETING WORK ON MURRAY STREET, WARREN STREET, AND WEST STREET.
- THE CONTRACTOR SHALL BE RESPONSIBLE FOR ALL MAINTENANCE OF TRAFFIC. MAINTENANCE AND PROTECTION OF TRAFFIC SHALL BE IN ACCORDANCE WITH THE REQUIREMENTS OF THE CITY OF NEW YORK DEPARTMENT OF TRANSPORTATION AND THE D.O.T. MANUAL ON UNIFORM TRAFFIC CONTROL DEVICES (M.U.T.C.D.) AND NEW YORK STATE D.O.T. STANDARDS.
- ALL SHEETING PLACED UNDER THIS CONTRACT SHALL BE REMOVED UPON COMPLETION OF THE CONTRACT WORK, AND THE COST SHALL BE DEEMED INCLUDED IN THE PRICES BID FOR ALL SCHEDULED ITEMS. THE SHEETING SHALL CONFORM TO THE REQUIREMENTS OF TITLE 29 CODE OF FEDERAL REGULATIONS, PART 1926, SAFETY AND HEALTH REGULATIONS FOR CONSTRUCTION (OSHA).
- THE CONTRACTOR SHALL MAINTAIN SAFE AND ADEQUATE VEHICULAR AND PEDESTRIAN ACCESS TO ADJACENT PROPERTIES. ACCESSIBILITY TO FIRE HYDRANTS AND PROVISION FOR THE INGRESS AND EGRESS OF EMERGENCY VEHICLES INCLUDING POLICE, FIRE AND AMBULANCE VEHICLES SHALL BE REQUIRED AT ALL TIMES.
- AREAS DISTURBED BY THE INSTALLATION OF THE NEW WORK SHALL BE RESTORED TO IN KIND UPON COMPLETION OF WORK.
- ALL WORK SHALL BE INSTALLED WITHIN THE SPACE PROVIDED AS SHOWN ON THE DRAWINGS. ANY ITEMS WHICH CANNOT BE INSTALLED WITHIN THE SPACE PROVIDED SHALL BE BROUGHT TO THE ATTENTION OF THE BPCA'S REPRESENTATIVE PRIOR TO INSTALLATION OF ANY WORK IN THAT AREA.
- ALL GRADING AND FILL MUST COMPLY WITH NYC BUILDING CODE APPENDIX G303.7.
- ALL UTILITIES SHALL BE ADEQUATELY PROTECTED AGAINST FLOOD DAMAGE. UNDERGROUND TANKS SHALL COMPLY WITH NYC BUILDING CODE APPENDIX G307.1 AND STORMWATER INLETS AND PIPING SHALL COMPLY WITH NYC BUILDING CODE APPENDIX G307.2.
- AN EMERGENCY FLOOD MANUAL WILL BE PROVIDED WITH INSTRUCTIONS FOR BEFORE, DURING, AND AFTER A FLOOD EVENT AT THE SITE IN ACCORDANCE WITH APPENDIX G 6.2.3 AND ASCE 24.

FIRE PREVENTION NOTES

- THERE SHALL BE NO OPEN FLAME OR SPARK PRODUCING DEVICE, EXCEPT AS PERMITTED BY 27-4079 OF THE ADMINISTRATIVE CODE. THE APPLICABLE PROVISIONS OF CHAPTER 27 OF THE ADMINISTRATIVE CODE WILL BE COMPLIED WITHIN ALL RESPECTS. MAINTAIN FIRE FIGHTING EQUIPMENT AS DIRECTED BY THE FIRE COMMISSIONER. THE PROVISIONS OF 27-438 THROUGH 27-442 OF THE ADMINISTRATIVE CODE TO BE COMPLIED WITHIN ALL RESPECTS. INSTALLATION OF TANKS TO BE MADE BY A LICENSED INSTALLER OF PETROLEUM PRODUCT STORAGE TANKS.
- THE CONTRACTOR SHALL SUPPLY AND INSTALL A 20-POUND ABC RATED FIRE EXTINGUISHER AT THE PROJECT SITE. THE FIRE EXTINGUISHERS SHALL BE MODEL TGP20G AS MANUFACTURED BY GENERAL FIRE EXTINGUISHERS CO. OR AN APPROVED EQUAL.

UTILITY SERVICE NOTES

- THE CONTRACTOR SHALL BE RESPONSIBLE FOR PREPARING AND FILING ANY UTILITY DISCONNECT ORDERS OR NEW CONNECTION REQUESTS FOR WATER, TELECOMMUNICATIONS, ELECTRIC, SEWER AND GAS LINES FOR AFFECTED FACILITIES WITHIN THE PROJECT WORK AREA.

- ALL ABANDONED UNDERGROUND UTILITIES, SEWER AND/OR WATER STRUCTURES ENCOUNTERED DURING CONSTRUCTION SHALL BE REMOVED TO A POINT 2 FEET BEYOND THE LIMIT OF THE NEW WORK. ENDS OF ABANDONED PIPES SHALL BE CAPPED OR PLUGGED WITH CONCRETE TO 6 INCHES MINIMUM THICKNESS. TOPS OF ABANDONED UNDERGROUND STRUCTURES SHALL BE REMOVED TO A POINT 2 FEET BELOW THE LIMIT OF NEW WORK AND THEIR BASE FILLED WITH COMPACTED CLEAN SAND.
- THE CONTRACTOR SHALL EXERCISE CAUTION WHEN REGRADING AND/OR REPAVING OVER EXISTING/NEW UTILITIES INCLUDING, BUT NOT LIMITED TO STORM AND SANITARY SEWERS, WATER MAINS, GAS AND ELECTRIC LINES.

DRAINAGE NOTES

- ALL PROPOSED DRAINAGE WORK SHALL BE DONE IN CONFORMANCE WITH THE LATEST STANDARDS OF THE NEW YORK CITY DEPARTMENT OF ENVIRONMENTAL PROTECTION UNLESS OTHERWISE NOTED.
- ALL EXISTING SEWER MANHOLES WITHIN THE CONTRACT LIMITS SHALL BE ADJUSTED TO MATCH FINAL GRADE ELEVATIONS. ANY MANHOLES THAT HAVE BEEN DAMAGED, WORN OR HAVE NONSTANDARD FRAMES AND COVERS SHALL BE PROVIDED WITH NEW 27-INCH CASTINGS IN ACCORDANCE WITH THE LATEST STANDARDS OF NYCDEP INCLUDING ANY NECESSARY MODIFICATIONS OF THE MANHOLE MASONRY.
- ANY DAMAGE TO MANHOLES OR SEWERS CAUSED BY THE CONTRACTOR'S WORK SHALL BE REPAIRED OR REPLACED BY THE CONTRACTOR, AS DIRECTED BY THE ENGINEER, AT NO COST TO THE AUTHORITY OR BPCA.
- ALL STORM DRAINAGE STRUCTURES AND PIPING SHALL BE CLEANED AND FLUSHED UPON COMPLETION OF CONSTRUCTION, STARTING FROM ROOF DRAINS ON TO THE FINAL CONNECTION(S) AT THE MUNICIPAL SEWER.
- POSITIVE DRAINAGE SHALL BE MAINTAINED AWAY FROM THE BUILDING, AT ALL TIMES.

PAVING NOTES (NYC/NYS DOT RIGHT-OF-WAY)

- ALL MATERIALS, CONSTRUCTION METHODS AND WORKMANSHIP SHALL CONFORM WITH THE LATEST STANDARD DETAILS AND SPECIFICATIONS OF THE NYC AND NYS DOT BUREAU OF HIGHWAY OPERATIONS.
- THE CONTRACTOR SHALL BE RESPONSIBLE FOR MAINTAINING A SAFE CONSTRUCTION AREA, AND PROVIDING FOR PEDESTRIAN AND VEHICULAR TRAFFIC FLOW AROUND THE CONSTRUCTION SITE IN ACCORDANCE WITH NYCDOT AND NYSDOT, OFFICE OF CONSTRUCTION MITIGATION AND CONTROL (OCMC).
- THE CONTRACTOR SHALL PROVIDE A MAINTENANCE AND PROTECTION OF TRAFFIC PLAN (MPT) IN ACCORDANCE WITH NYS DOT REQUIREMENTS FOR THE WORK ALONG WEST STREET.
- WHERE A NEW PAVEMENT OR SIDEWALK IS INSTALLED THE CONTRACTOR IS RESPONSIBLE FOR THE ADJUSTMENT OF ALL EXISTING HANDHOLES, MANHOLE COVERS, CATCH BASINS, AND VALVE BOXES AS REQUIRED TO MEET THE NEW GRADES. ALL UTILITY STRUCTURES WITHIN THE CONSTRUCTION AREA SHALL REMAIN AND BE MAINTAINED THROUGHOUT CONSTRUCTION.
- ALL EXISTING AND/OR PROPOSED GUTTER FLOW WITHIN THE PROJECT AREA SHALL BE MAINTAINED SO AS NOT TO CAUSE ANY PONDING CONDITIONS.
- ALL EXISTING NYCDEP DRAINAGE STRUCTURES ARE TO BE CLEANED AND MADE OPERABLE AROUND THE SITE AT THE COMPLETION OF CONSTRUCTION.
- ALL PAVEMENT MARKINGS, INCLUDING THERMOPLASTIC LANE DIVIDERS, REMOVED DURING CONSTRUCTION, SHALL BE REPLACED IN-KIND, AND IN ACCORDANCE WITH THE BUREAU OF TRAFFIC OPERATIONS STANDARDS.
- THE CONTRACTOR WILL REPLACE ANY MISSING, BROKEN, OR EXISTING CURB, SIDEWALK OR ROADWAY DAMAGED PRIOR TO OR DURING CONSTRUCTION AND REPAIR AS DIRECTED BY THE BOROUGH, NYC DOT, OR NYS DOT MAINTENANCE ENGINEER.
- NEW SIDEWALKS AND CURB INSTALLATIONS ARE TO MATCH EXISTING GRADES AND CONDITIONS AT ABUTTING PROPERTY BOUNDARIES WITH NO TRIP HAZARDS.
- WHERE EXISTING CONCRETE PAVEMENT OR ASPHALT CONCRETE PAVEMENT ARE REMOVED, THE CONTRACTOR SHALL SAWCUT AND CLEANLY TRIM EDGE OF REMAINING PAVEMENT BEFORE INSTALLING NEW CONSTRUCTION.
- EXISTING PAVEMENT IN THE AREAS OF NEW PAVEMENT SHALL BE ENTIRELY REMOVED AND DISPOSED OF BY THE CONTRACTOR. THE SUBGRADE SHALL BE PREPARED AS PER THE CONTRACT SPECIFICATIONS AND DETAILS AND BROUGHT TO THE REQUIRED ELEVATION.
- THE CONTRACTOR SHALL ENSURE THAT PAVEMENT SLOPES FROM REPAVING ACTIVITIES WILL PROVIDE POSITIVE DRAINAGE TOWARD EXISTING CATCH BASINS.
- THE CONTRACTOR SHALL ENSURE THAT EDGES OF NEW PAVEMENT MATCH THE EDGES OF ABUTTING EXISTING PAVEMENT AS TO NOT CREATE ANY TRIP HAZARDS.

EROSION AND SEDIMENT CONTROL NOTES

- ALL EROSION AND SEDIMENT CONTROL (ESC) MEASURES SHALL CONFORM TO THE STANDARDS SET FORTH IN THE LATEST EDITION OF THE "NEW YORK STATE STANDARDS AND SPECIFICATIONS FOR EROSION AND SEDIMENT CONTROL".
- ALL ESC MEASURES SHALL BE INSTALLED PRIOR TO ANY MAJOR PAVEMENT REMOVAL OR EARTHWORK, OR IN THEIR PROPER SEQUENCE, AND MAINTAINED UNTIL PERMANENT PROTECTION IS ESTABLISHED.
- ALL STORM DRAIN INLETS SHALL BE PROTECTED WITH FILTER FABRIC OR HAY BALES UNTIL PAVING HAS BEEN ESTABLISHED.
- ANY DAMAGE INCURRED BY EROSION SHALL BE INSPECTED AND MAINTAINED PERIODICALLY AFTER ALL STORM EVENTS.
- THE CONTRACTOR SHALL PROVIDE AN EROSION AND SEDIMENT CONTROL PLAN IN CONJUNCTION WITH THE PHASING AND LOGISTICS PLAN FOR APPROVAL PRIOR TO CONSTRUCTION START.
- EXISTING TREES TO REMAIN SHALL BE PROTECTED PER NYC DOT AND DPR STANDARDS. SEE LANDSCAPING DRAWINGS FOR ADDITIONAL INFORMATION.

EXCAVATION NOTES

- THE FOLLOWING INFORMATION IS TO BE USED AS A GUIDE ONLY. IN THE EVENT OF A CONFLICT BETWEEN THIS INFORMATION AND OSHA OR OTHER LOCAL REGULATIONS, THE MOST RESTRICTIVE REGULATIONS AND REQUIREMENTS SHALL GOVERN ALL EXCAVATION WORK.
- TRENCHING, SHORING - SECTIONS 1962.50 THROUGH 1926.653 AND ARTICLE 4, SECTION 27-1032 THE CONTRACTOR SHALL COMPLY WITH ALL REQUIREMENTS OF OSHA SUBSECTION P. EXCAVATIONS, OF THE NEW YORK CITY BUILDING CODE.
- THE CONTRACTOR SHALL NOTIFY THE PROJECT ENGINEER WHEN EXCAVATIONS ARE ADJACENT TO PROPERTY LINES, ROADS, AND SIDEWALKS. PARTICULARLY WHERE BUILDINGS ON ABUTTING PROPERTY ARE NEAR THE PROPERTY LINE.
- THE CONTRACTOR SHALL CUT BACK AND SHEET AS NECESSARY FOR STABILITY, SAFETY, AND PROTECTION OF UTILITIES, STRUCTURES, STOCKPILED MATERIAL AND EQUIPMENT. IN THE EVENT THAT SHEETING AND/OR SHORING ARE NECESSARY, THE CONTRACTOR SHALL BE RESPONSIBLE FOR PROVIDING ALL NECESSARY SHORING DESIGN COMPUTATIONS AND DETAILS SIGNED BY AN ENGINEER LICENSED TO PRACTICE IN NEW YORK STATE, TO THE BPCA'S REPRESENTATIVE FOR APPROVAL.
- THE CONTRACTOR MUST TAKE ALL NECESSARY PRECAUTIONS TO LOCATE ALL EXISTING UTILITIES AND APPURTENANCES TO REMAIN IN PLACE PRIOR TO THE START OF EXCAVATION. ANY BURIED UTILITIES ENCOUNTERED WHICH WERE NOT IDENTIFIED BEFORE THE START OF EXCAVATION SHALL BE REPORTED TO THE BPCA'S REPRESENTATIVE.
- ALL EXCAVATED SOIL MUST BE REPLACED WITH APPROVED BACKFILL. BACKFILL MATERIALS SHALL NOT BE PLACED WITHOUT WRITTEN APPROVAL FROM THE BPCA'S REPRESENTATIVE.
- ALL EXCAVATIONS GREATER THAN 5'-0" IN DEPTH MUST BE SHORED OR SLOPED AS PER OSHA, UNLESS IN ROCK, SHALE OR CEMENTED SANDS AND GRAVELS.

STV 100 Years
 STV INCORPORATED
 225 PARK AVENUE SOUTH
 5TH FLOOR
 NEW YORK, NY 10003
 www.stvinc.com

CONSULTANTS

SITWORKS
 LANDSCAPE ARCHITECTURE, LLC
 150 WEST 28TH STREET
 SUITE 605
 NEW YORK, NY 10001
 www.siteworkscm.com

SEALS

PROJECT IDENTIFICATION

 **Battery Park City Authority**
 BATTERY PARK CITY
 BALLFIELD AND COMMUNITY
 CENTER

C	11/01/19	ISSUE FOR BID - 95%	ET
B	10/18/19	75% DESIGN SUBMITTAL	SB
A	09/06/19	50% DESIGN SUBMITTAL	SB
MARK	DATE	DESCRIPTION	BY

ISSUE BLOCK

PROJECT NO.:	3019666
DESIGNED BY:	JA
DRAWN BY:	JA
CHECKED BY:	SB
APPROVED BY:	SB
COPYRIGHT:	STV, INC

SHEET TITLE

**CIVIL GENERAL
 NOTES**

C-001

LEGEND

EXISTING	EXISTING TO BE REMOVED	NEW	DESCRIPTION
			BUILDING
			PROPERTY LINE
			BITUMINOUS PAVING
			CONCRETE PAVEMENT
			GRASS/LANDSCAPED AREA/TURF
			PAVERS
			SAW CUT PAVEMENT
			CONCRETE CURB
			CONCRETE WALL
			CONTOUR ELEVATION (MAJOR)
			CONTOUR ELEVATION (MINOR)
			SPOT ELEVATION
			BOTTOM/TOP OF WALL/CURB ELEVATION
			24' WELDED WIRE MESH FENCE
			GUIDE RAIL
			HAND RAIL
			SIGN
			LIGHT POLE
			METAL LIGHT POLE
			METAL MULTI-LIGHT TOWER
			METAL PEDESTRIAN SIGNAL
			METAL TRAFFIC LIGHT
			GUY WIRE
			WOODEN LIGHT POLE
			WOODEN POLE WITH 2 LIGHTS
			AREA DRAIN
			STORM PIPE
			CATCH BASIN
			STORM MANHOLE
			SANITARY SEWER
			SANITARY MANHOLE
			GAS VALVE
			GAS LINE
			WATER MANHOLE
			WATER LINE
			WATER VALVE
			WATER FOUNTAIN
			HYDRANT
			INLINE CHECK VALVE

LEGEND

EXISTING	EXISTING TO BE REMOVED	NEW	DESCRIPTION
			FIRE LINE
			ELECTRIC LINE
			ELECTRIC MANHOLE
			ELECTRIC BOX
			UNKNOWN MANHOLE
			UNKNOWN VALVE
			TREE
			BOLLARD
			VERIZON LINE
			COMMUNICATIONS LINE
			FIRE CALL BOX
			FLOW ARROW
			TREE PROTECTION
			INLET PROTECTION
			SEDIMENT FILTER LOG
			STOCKPILE
			CONSTRUCTION FENCE
			STABILIZED CONSTRUCTION ENTRANCE
			WALL ALIGNMENT STATION

ABBREVIATIONS

ASPH - ASPHALT	LT - LIGHT POLE
BC - BOTTOM OF CURB	M - # - MANHOLE NUMBER
BFE - BASE FLOOD ELEVATION	MGR - METAL GUIDE RAIL
BOL - BOLLARD	MH - MANHOLE
BUR - BURIED	MC - METAL COVER
BW - BOTTOM OF WALL	MHE - ELECTRIC MANHOLE
BXE - ELECTRIC BOX	MHS - SEWER MANHOLE
CB - CATCH BASIN	MHU - UNKNOWN MANHOLE
CC - CONCRETE CURB	MLP - METAL LIGHT POLE
CLF - CHAIN LINK FENCE	MPED - METAL PEDESTRIAN SIGNAL
COMM - COMMUNICATION	MTL - METAL TRAFFIC LIGHT
CONC - CONCRETE	MUT - METAL UTILITY POLE
COND - CONDUIT	PE - POLYETHYLENE
CSW - CONCRETE SIDEWALK	PL - PLASTIC
SSW - STONE SIDEWALK	R - RECORD
ECS - EMPIRE CITY SUBWAY (VERIZON)	RCP - REINFORCED CONCRETE PIPE
ESC - EROSION AND SEDIMENT CONTROL	RET - RETIRED
ESVP - EXTRA STRENGTH VITRIFIED PIPE	RGS - RIGID GALVANIZED STEEL
DC - DEPRESSED CURB	SFC - STEEL FACE CURB
DE - DEAD END	SN - SIGN
DFE - DESIGN FLOOD ELEVATION	ST - STEEL PIPE
D.I. - DUCTILE IRON	STP - STANDPIPE
DIP - DUCTILE IRON PIPE	TC - TOP OF CURB
DN - DOWN	TW - TOP OF WALL
D.P. - DUCTILE PRECAST	TYP - TYPICAL
EB - ELECTRIC BOX	UV - UNKNOWN VALVE
EL - ELEVATION	VER - VERIZON
ELEC - ELECTRIC	VP - VENT PIPE
EOP - END OF PAVEMENT	VS - # - VAULT NUMBER
GR - GRATE	WV - WATER VALVE
GV - GAS VALVE	WLP - WOODEN LIGHT POLE
HDPE - HIGH DENSITY POLYETHYLENE PIPE	
HYD - HYDRANT	

STV 100 Years
 STV INCORPORATED
 225 PARK AVENUE SOUTH
 5TH FLOOR
 NEW YORK, NY 10003
 www.stvinc.com

CONSULTANTS
SITWORKS
 LANDSCAPE ARCHITECTURE, LLC
 150 WEST 28TH STREET
 SUITE 605
 NEW YORK, NY 10001
 www.sitworks.com

SEALS

PROJECT IDENTIFICATION

Battery Park City Authority
 BATTERY PARK CITY
 BALLFIELD AND COMMUNITY CENTER

MARK	DATE	DESCRIPTION	BY
C	11/01/19	ISSUE FOR BID - 95%	ET
B	10/18/19	75% DESIGN SUBMITTAL	SB
A	09/06/19	50% DESIGN SUBMITTAL	SB

ISSUE BLOCK

PROJECT NO.:	3019666
DESIGNED BY:	JA
DRAWN BY:	JA
CHECKED BY:	SB
APPROVED BY:	SB
COPYRIGHT:	STV, INC

SHEET TITLE
CIVIL LEGEND AND ABBREVIATIONS

C-002

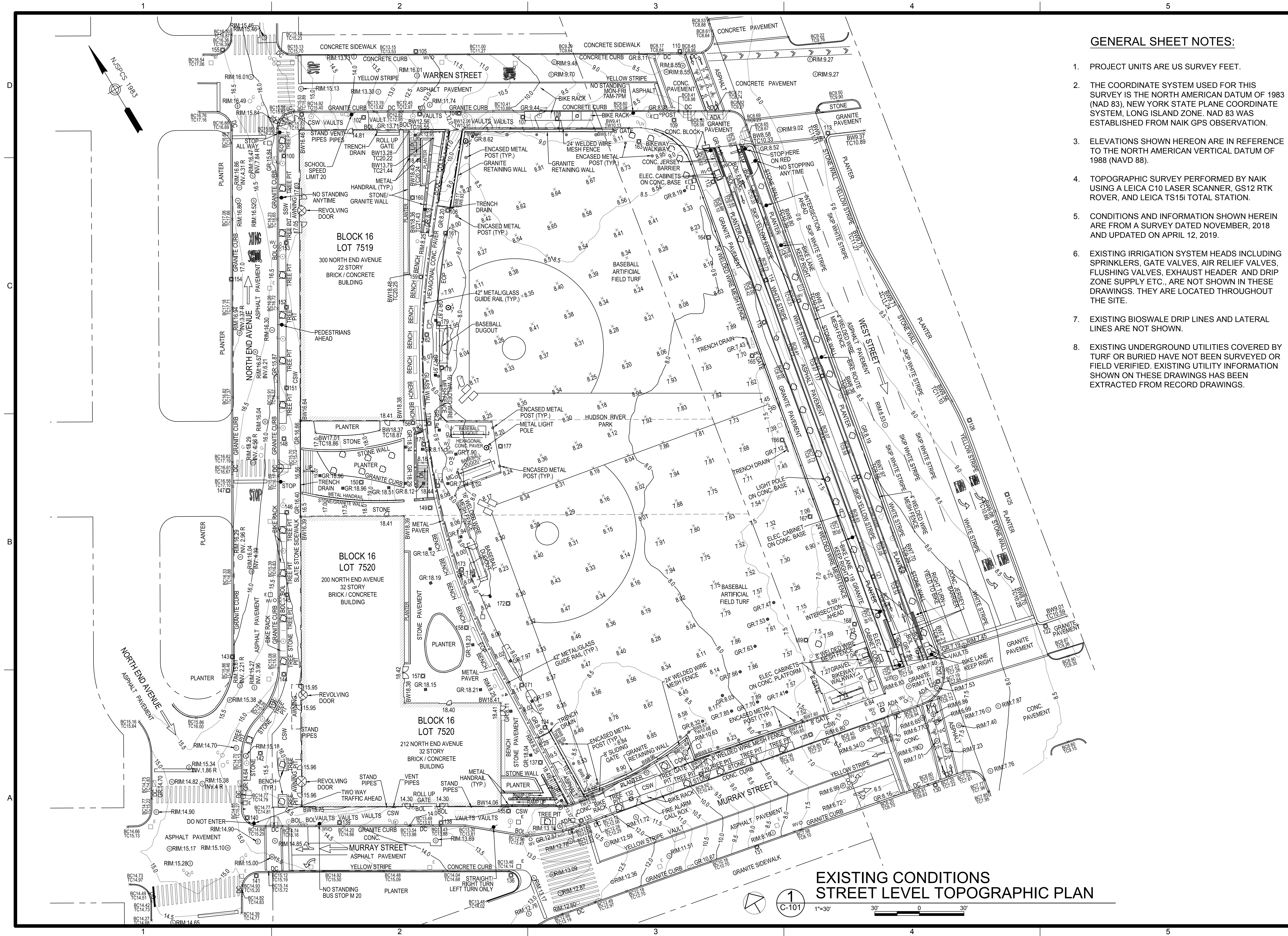

**EXISTING CONDITIONS
STREET LEVEL TOPOGRAPHIC PLAN**

1
C-101
1"=30'

GENERAL SHEET NOTES:

- PROJECT UNITS ARE US SURVEY FEET.
- THE COORDINATE SYSTEM USED FOR THIS SURVEY IS THE NORTH AMERICAN DATUM OF 1983 (NAD 83), NEW YORK STATE PLANE COORDINATE SYSTEM, LONG ISLAND ZONE. NAD 83 WAS ESTABLISHED FROM NAIK GPS OBSERVATION.
- ELEVATIONS SHOWN HEREON ARE IN REFERENCE TO THE NORTH AMERICAN VERTICAL DATUM OF 1988 (NAVD 88).
- TOPOGRAPHIC SURVEY PERFORMED BY NAIK USING A LEICA C10 LASER SCANNER, GS12 RTK ROVER, AND LEICA TS15i TOTAL STATION.
- CONDITIONS AND INFORMATION SHOWN HEREIN ARE FROM A SURVEY DATED NOVEMBER, 2018 AND UPDATED ON APRIL 12, 2019.
- EXISTING IRRIGATION SYSTEM HEADS INCLUDING SPRINKLERS, GATE VALVES, AIR RELIEF VALVES, FLUSHING VALVES, EXHAUST HEADER AND DRIP ZONE SUPPLY ETC., ARE NOT SHOWN IN THESE DRAWINGS. THEY ARE LOCATED THROUGHOUT THE SITE.
- EXISTING BIOSWALE DRIP LINES AND LATERAL LINES ARE NOT SHOWN.
- EXISTING UNDERGROUND UTILITIES COVERED BY TURF OR BURIED HAVE NOT BEEN SURVEYED OR FIELD VERIFIED. EXISTING UTILITY INFORMATION SHOWN ON THESE DRAWINGS HAS BEEN EXTRACTED FROM RECORD DRAWINGS.

STV 100 Years
 STV INCORPORATED
 225 PARK AVENUE SOUTH
 5TH FLOOR
 NEW YORK, NY 10003
 www.stvinc.com
 CONSULTANTS

SITWORKS
 LANDSCAPE ARCHITECTURE, LLC
 150 WEST 28TH STREET
 SUITE 605
 NEW YORK, NY 10001
 www.sitworkscom.com

SEALS

PROJECT IDENTIFICATION

NEW YORK STATE OF OPPORTUNITY	Battery Park City Authority
BATTERY PARK CITY BALLFIELD AND COMMUNITY CENTER	

MARK	DATE	DESCRIPTION	BY
C	11/01/19	ISSUE FOR BID - 95%	ET
B	10/18/19	75% DESIGN SUBMITTAL	SB
A	09/06/19	50% DESIGN SUBMITTAL	SB

ISSUE BLOCK

PROJECT NO.:	3019666
DESIGNED BY:	JA
DRAWN BY:	JA
CHECKED BY:	SB
APPROVED BY:	SB
COPYRIGHT:	STV, INC

SHEET TITLE
**EXISTING CONDITIONS
STREET LEVEL**

C-101

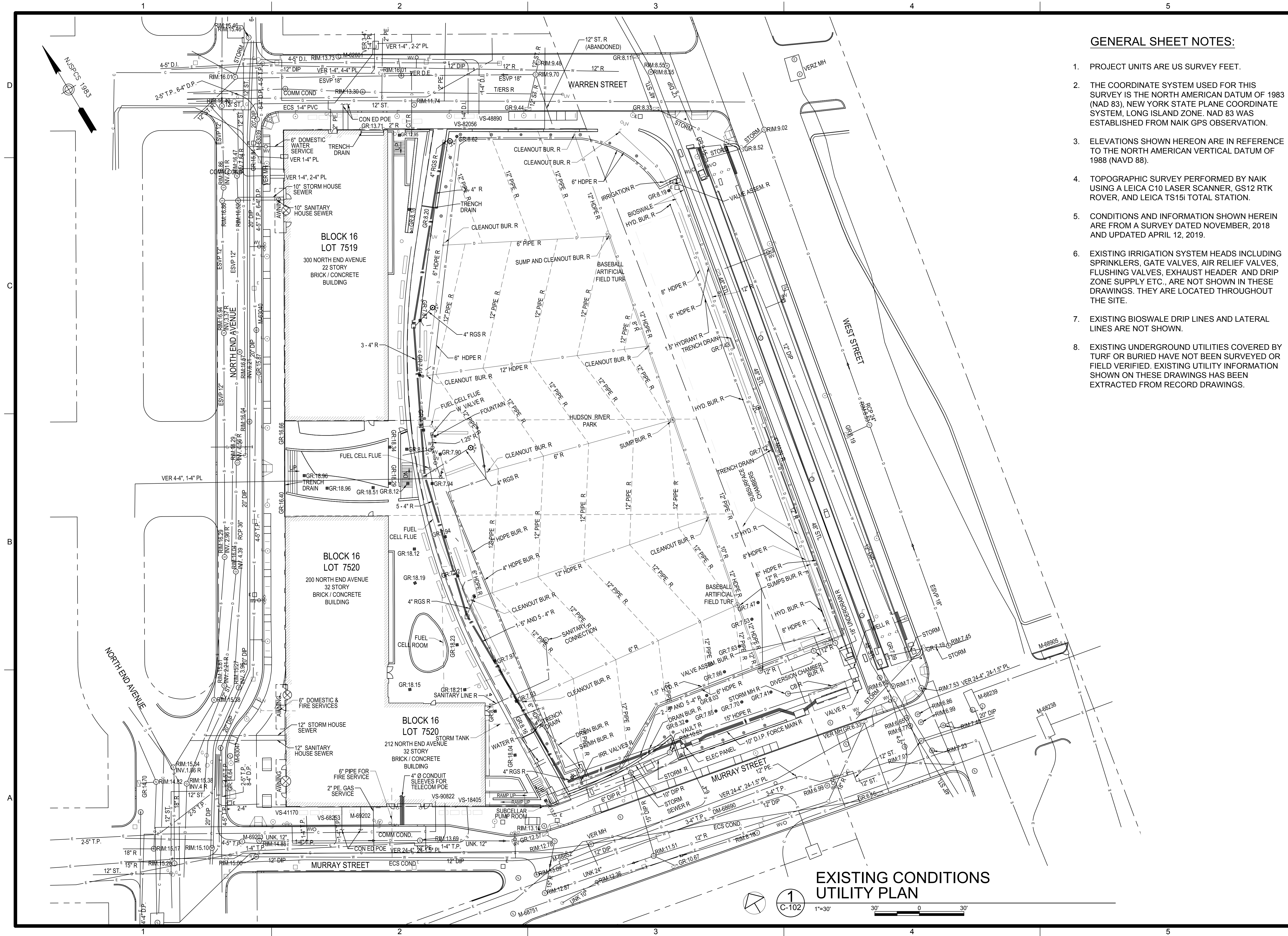

GENERAL SHEET NOTES:

- PROJECT UNITS ARE US SURVEY FEET.
- THE COORDINATE SYSTEM USED FOR THIS SURVEY IS THE NORTH AMERICAN DATUM OF 1983 (NAD 83), NEW YORK STATE PLANE COORDINATE SYSTEM, LONG ISLAND ZONE. NAD 83 WAS ESTABLISHED FROM NAIK GPS OBSERVATION.
- ELEVATIONS SHOWN HEREON ARE IN REFERENCE TO THE NORTH AMERICAN VERTICAL DATUM OF 1988 (NAVD 88).
- TOPOGRAPHIC SURVEY PERFORMED BY NAIK USING A LEICA C10 LASER SCANNER, GS12 RTK ROVER, AND LEICA TS15i TOTAL STATION.
- CONDITIONS AND INFORMATION SHOWN HEREIN ARE FROM A SURVEY DATED NOVEMBER, 2018 AND UPDATED APRIL 12, 2019.
- EXISTING IRRIGATION SYSTEM HEADS INCLUDING SPRINKLERS, GATE VALVES, AIR RELIEF VALVES, FLUSHING VALVES, EXHAUST HEADER AND DRIP ZONE SUPPLY ETC., ARE NOT SHOWN IN THESE DRAWINGS. THEY ARE LOCATED THROUGHOUT THE SITE.
- EXISTING BIOSWALE DRIP LINES AND LATERAL LINES ARE NOT SHOWN.
- EXISTING UNDERGROUND UTILITIES COVERED BY TURF OR BURIED HAVE NOT BEEN SURVEYED OR FIELD VERIFIED. EXISTING UTILITY INFORMATION SHOWN ON THESE DRAWINGS HAS BEEN EXTRACTED FROM RECORD DRAWINGS.

STV 100 Years
 STV INCORPORATED
 225 PARK AVENUE SOUTH
 5TH FLOOR
 NEW YORK, NY 10003
 www.stvinc.com

CONSULTANTS
SITWORKS
 LANDSCAPE ARCHITECTURE, LLC
 150 WEST 28TH STREET
 SUITE 605
 NEW YORK, NY 10001
 www.sitworkscom.com

SEALS

PROJECT IDENTIFICATION
Battery Park City Authority
 BATTERY PARK CITY
 BALLFIELD AND COMMUNITY CENTER

MARK	DATE	DESCRIPTION	BY
C	11/01/19	ISSUE FOR BID - 95%	ET
B	10/18/19	75% DESIGN SUBMITTAL	SB
A	09/06/19	50% DESIGN SUBMITTAL	SB

ISSUE BLOCK

PROJECT NO.:	3019666
DESIGNED BY:	JA
DRAWN BY:	JA
CHECKED BY:	SB
APPROVED BY:	SB
COPYRIGHT:	STV, INC

SHEET TITLE
**EXISTING CONDITIONS
 UTILITY PLAN**

C-102

**EXISTING CONDITIONS
 UTILITY PLAN**



GENERAL SHEET NOTES

1. REFER TO C-001 AND C-002 FOR CIVIL GENERAL NOTES, LEGEND, AND ABBREVIATIONS.
2. REFER TO LANDSCAPING DRAWINGS AND G-003 FOR TREE PROTECTION PLAN.
3. REFER TO C-131 AND C-132 FOR EROSION AND SEDIMENT CONTROL PLANS.

SHEET KEYNOTES

- D1. REMOVE EXISTING CONCRETE PAVING OR SIDEWALK INCLUDING SUBBASE. IF SIDEWALK REMOVAL CUTS INTO ADJACENT SLAB EXTEND SIDEWALK REMOVAL AND REPLACEMENT TO NEXT JOINT.
- D2. SAWCUT EXISTING CONCRETE PAVING OR SIDEWALK.
- D3. REMOVE EXISTING CONCRETE CURB IN ITS ENTIRETY.
- D4. REMOVE AND SALVAGE EXISTING CONCRETE BARRIER.
- D5. REMOVE EXISTING PAVERS AND SUBBASE. SALVAGE PAVERS IN GOOD CONDITION FOR REUSE.
- D6. PROTECT EXISTING TREES. SEE LANDSCAPING DRAWINGS FOR DETAILS.
- D7. REMOVE EXISTING TREE IN ITS ENTIRETY. SEE LANDSCAPING DRAWINGS FOR DETAILS.
- D8. EXISTING FENCE TO REMAIN IN PLACE AND BE PROTECTED DURING CONSTRUCTION.
- D9. REMOVE AND SALVAGE HIGH WELDED WIRE MESH FENCE AND GATE, FOR REUSE.
- D10. CLEAR AND GRUB AS REQUIRED FOR INSTALLATION OF NEW FLOOD WALL.
- D11. INSPECT EXISTING CATCH BASIN TO DETERMINE IF STRUCTURE AND ASSOCIATED PIPING HAVE BEEN CAPPED OR FILLED. IF ABANDONED, REMOVE CATCH BASIN AND ASSOCIATED STORM PIPING WITHIN THE WORK LIMITS. INFORM ENGINEER IF OTHERWISE.
- D12. PROTECT EXISTING TRENCH DRAINS AND BELOW GRADE BIOSWALE AND DETENTION SYSTEM DURING CONSTRUCTION.
- D13. REMOVE EXISTING TOP LAYER OF TURF AS NEEDED FOR INSTALLATION OF NEW WORK. ALIGN REMOVAL EDGE WITH EDGE OF EXISTING PLANTING BED.

SEALS

PROJECT IDENTIFICATION

NEW YORK STATE OF OPPORTUNITY | **Battery Park City Authority**
 BATTERY PARK CITY
 BALLFIELD AND COMMUNITY CENTER

MARK	DATE	DESCRIPTION	BY
C	11/01/19	ISSUE FOR BID - 95%	ET
B	10/18/19	75% DESIGN SUBMITTAL	SB
A	09/06/19	50% DESIGN SUBMITTAL	SB

ISSUE BLOCK

PROJECT NO.:	3019666
DESIGNED BY:	JA
DRAWN BY:	JA
CHECKED BY:	SB
APPROVED BY:	SB
COPYRIGHT:	STV, INC

SHEET TITLE

SITE DEMOLITION PLAN
 SHEET 1 OF 2

C-103

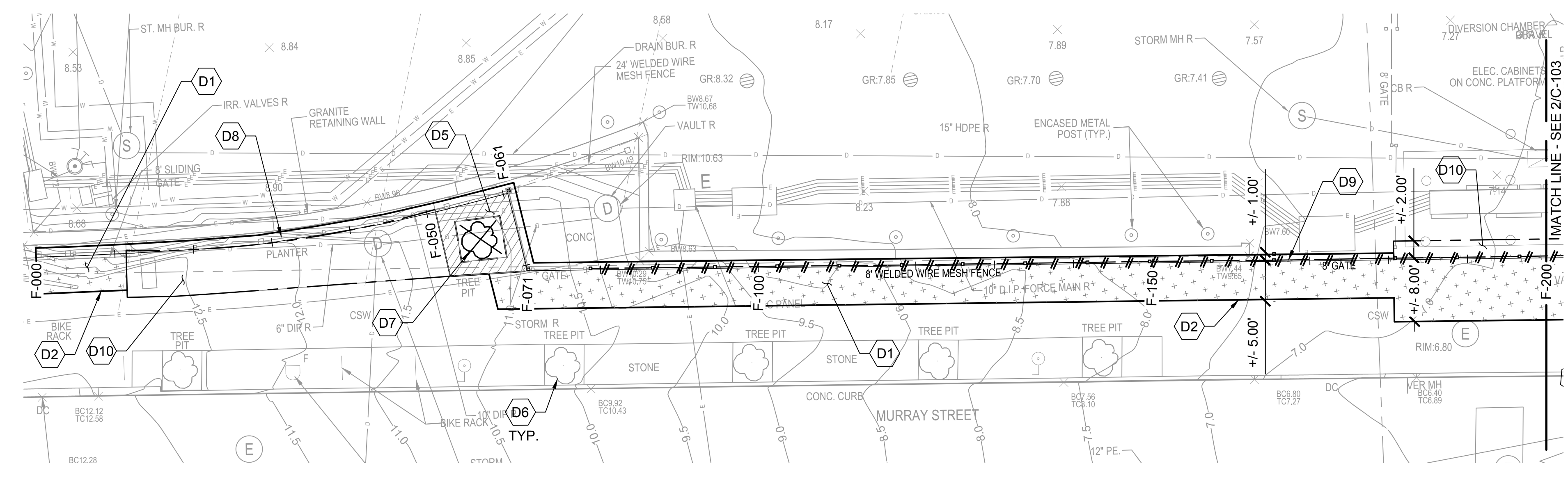

1 SITE DEMOLITION PLAN - AREA 1
 C-103 1"=10' 10' 5' 0' 10'

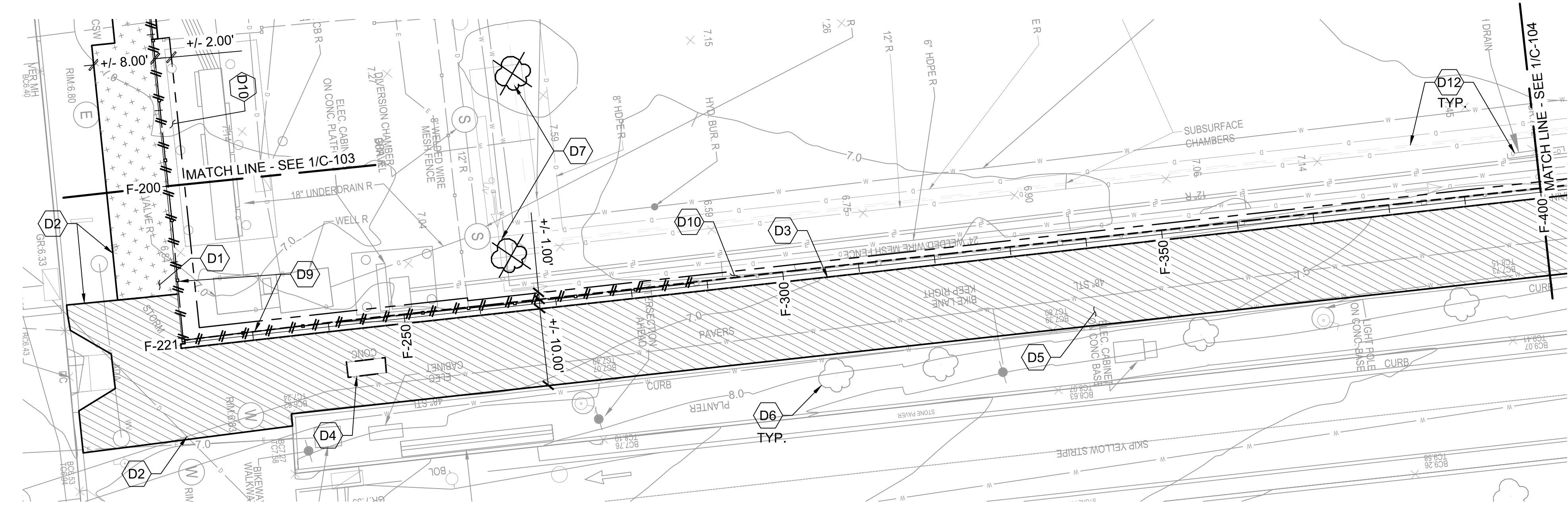

2 SITE DEMOLITION PLAN - AREA 2
 C-103 1"=10' 10' 5' 0' 10'

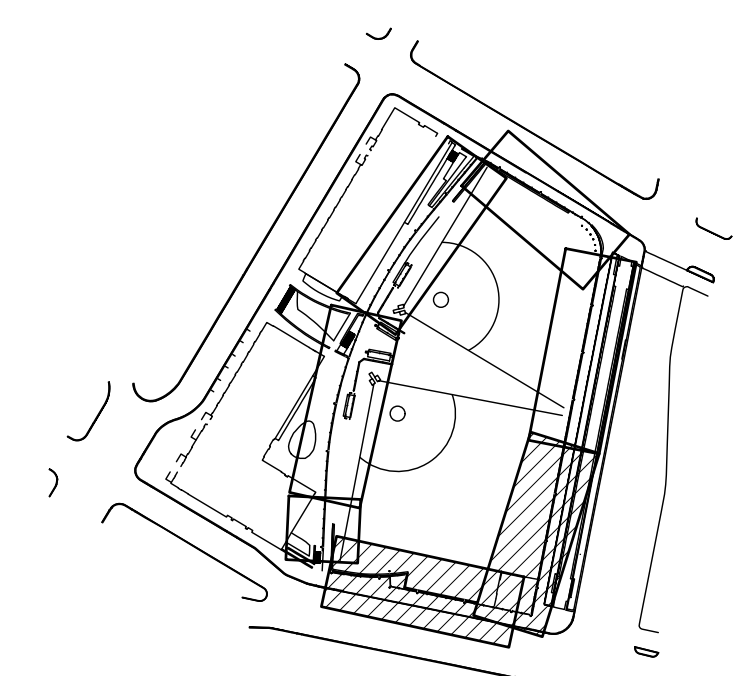

KEY PLAN
 NOT TO SCALE

CONSULTANTS

GENERAL SHEET NOTES

- REFER TO C-001 AND C-002 FOR CIVIL GENERAL NOTES, LEGEND, AND ABBREVIATIONS.
- REFER TO LANDSCAPING DRAWINGS AND G-003 FOR TREE PROTECTION PLAN.
- REFER TO C-131 AND C-132 FOR EROSION AND SEDIMENT CONTROL PLANS.

SHEET KEYNOTES

- REMOVE EXISTING CONCRETE PAVING OR SIDEWALK INCLUDING SUBBASE. IF SIDEWALK REMOVAL CUTS INTO ADJACENT SLAB EXTEND SIDEWALK REMOVAL AND REPLACEMENT TO NEXT JOINT.
- SAWCUT EXISTING CONCRETE PAVING OR SIDEWALK.
- REMOVE EXISTING CONCRETE CURB IN ITS ENTIRETY.
- REMOVE AND SALVAGE EXISTING CONCRETE BARRIER.
- REMOVE EXISTING PAVERS AND SUBBASE. SALVAGE PAVERS IN GOOD CONDITION FOR REUSE.
- PROTECT EXISTING TREES. SEE LANDSCAPING DRAWINGS FOR DETAILS.
- REMOVE EXISTING TREE IN ITS ENTIRETY. SEE LANDSCAPING DRAWINGS FOR DETAILS.
- EXISTING FENCE TO REMAIN IN PLACE AND BE PROTECTED DURING CONSTRUCTION.
- REMOVE AND SALVAGE HIGH WELDED WIRE MESH FENCE AND GATE, FOR REUSE.
- CLEAR AND GRUB AS REQUIRED FOR INSTALLATION OF NEW FLOOD WALL.
- INSPECT EXISTING CATCH BASIN TO DETERMINE IF STRUCTURE AND ASSOCIATED PIPING HAVE BEEN CAPPED OR FILLED. IF ABANDONED, REMOVE CATCH BASIN AND ASSOCIATED STORM PIPING WITHIN THE WORK LIMITS. INFORM ENGINEER IF OTHERWISE.
- PROTECT EXISTING TRENCH DRAINS AND BELOW GRADE BIOSWALE AND DETENTION SYSTEM DURING CONSTRUCTION.
- REMOVE EXISTING TOP LAYER OF TURF AS NEEDED FOR INSTALLATION OF NEW WORK. ALIGN REMOVAL EDGE WITH EDGE OF EXISTING PLANTING BED.

SEALS

PROJECT IDENTIFICATION

NEW YORK STATE OF OPPORTUNITY
Battery Park City Authority
 BATTERY PARK CITY
 BALLFIELD AND COMMUNITY CENTER

MARK	DATE	DESCRIPTION	BY
C	11/01/19	ISSUE FOR BID - 95%	ET
B	10/18/19	75% DESIGN SUBMITTAL	SB
A	09/06/19	50% DESIGN SUBMITTAL	SB

ISSUE BLOCK

PROJECT NO.:	3019666
DESIGNED BY:	JA
DRAWN BY:	JA
CHECKED BY:	SB
APPROVED BY:	SB
COPYRIGHT:	STV, INC

SHEET TITLE

SITE DEMOLITION PLAN
 SHEET 2 OF 2

C-104

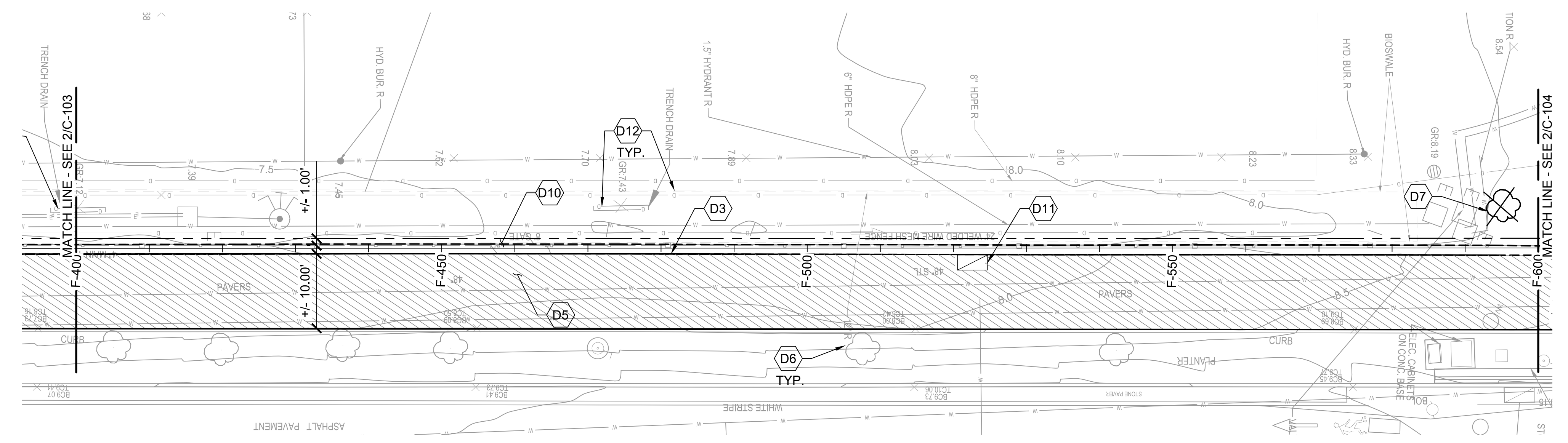

1 SITE DEMOLITION PLAN - AREA 3
 C-104 1"=10' 10' 5' 0' 10'

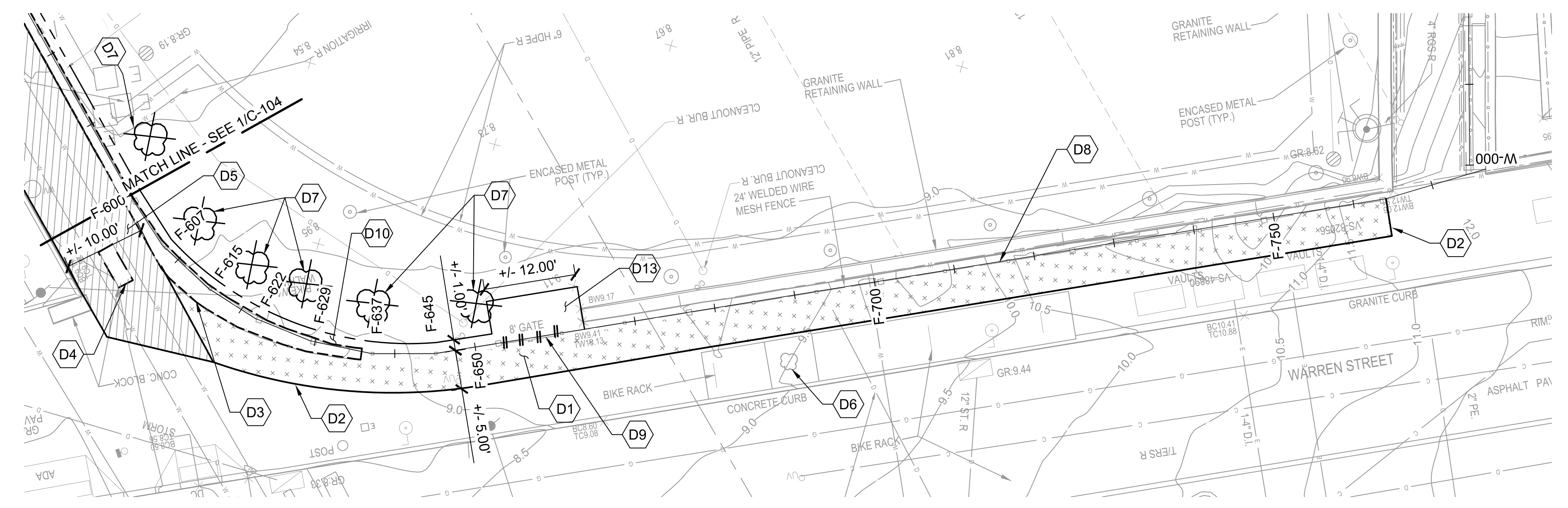

2 SITE DEMOLITION PLAN - AREA 4
 C-104 1"=10' 10' 5' 0' 10'

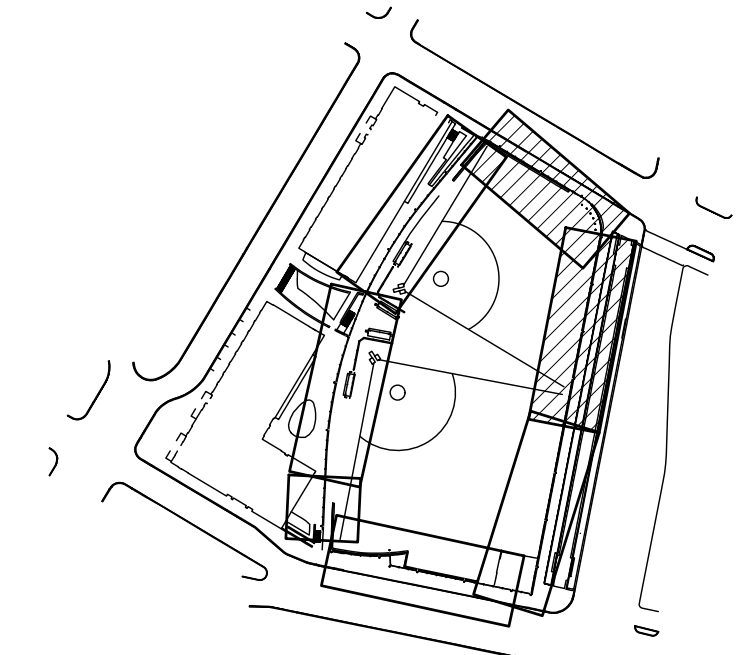

KEY PLAN
 NOT TO SCALE

CONSULTANTS

GENERAL SHEET NOTES

1. REFER TO C-001 AND C-002 FOR CIVIL GENERAL NOTES, LEGEND, AND ABBREVIATIONS.
2. REFER TO LANDSCAPING DRAWINGS FOR ARCHITECTURAL PANEL DETAILS.
3. REFER TO STRUCTURAL DRAWINGS FOR INTERIM FLOOD WALL PLANS, ELEVATIONS, AND DETAILS.

SHEET KEYNOTES

1. FURNISH AND INSTALL NYCDOT STANDARD CONCRETE SIDEWALK. REFER TO DETAIL 1/C-501.
2. FURNISH AND INSTALL PAVERS AND BASE COURSE TO MATCH ADJACENT PAVERS IN NYS DOT RIGHT OF WAY. SEE DETAIL 2/C-501. REUSE EXISTING PAVERS IN GOOD CONDITION OTHERWISE PROVIDE NEW PAVERS TO MATCH.
3. MATCH EXISTING CONCRETE PAVING OR PAVERS.
4. STEEL PLATE FLOOD WALL WITH ARCHITECTURAL PANEL ATTACHED TO EXISTING WELDED WIRE FENCE. REFER TO STRUCTURAL AND LANDSCAPING DRAWINGS FOR DETAILS.
5. REINSTALL SALVAGED CONCRETE BARRIERS.
6. 24" WIDE CONCRETE GRADE BEAM. SEE STRUCTURAL DRAWINGS FOR DETAILS.
7. REINSTALL SALVAGED WELDED WIRE MESH FENCE. SEE STRUCTURAL DRAWINGS FOR DETAILS.
8. FURNISH AND INSTALL FLOOD GATE. REINSTALL SALVAGED SECURITY GATES AT THE ORIGINAL LOCATION AFTER INSTALLATION OF FLOOD GATE.
9. RESTORE LANDSCAPED AREA.
10. INSTALL TREE. SEE LANDSCAPING DRAWINGS FOR DETAILS.
11. 10" WIDE CONCRETE FLOOD WALL. SEE STRUCTURAL DRAWINGS.
12. RESTORE TURF AREA. SEE LANDSCAPING DRAWINGS FOR DETAILS.

SEALS

PROJECT IDENTIFICATION

NEW YORK STATE OF OPPORTUNITY
Battery Park City Authority
 BATTERY PARK CITY
 BALLFIELD AND COMMUNITY CENTER

MARK	DATE	DESCRIPTION	BY
C	11/01/19	ISSUE FOR BID - 95%	ET
B	10/18/19	75% DESIGN SUBMITTAL	SB
A	09/06/19	50% DESIGN SUBMITTAL	SB

ISSUE BLOCK

PROJECT NO.:	3019666
DESIGNED BY:	JA
DRAWN BY:	JA
CHECKED BY:	SB
APPROVED BY:	SB
COPYRIGHT:	STV, INC

SHEET TITLE

SITE LAYOUT PLAN
SHEET 1 OF 2

C-111

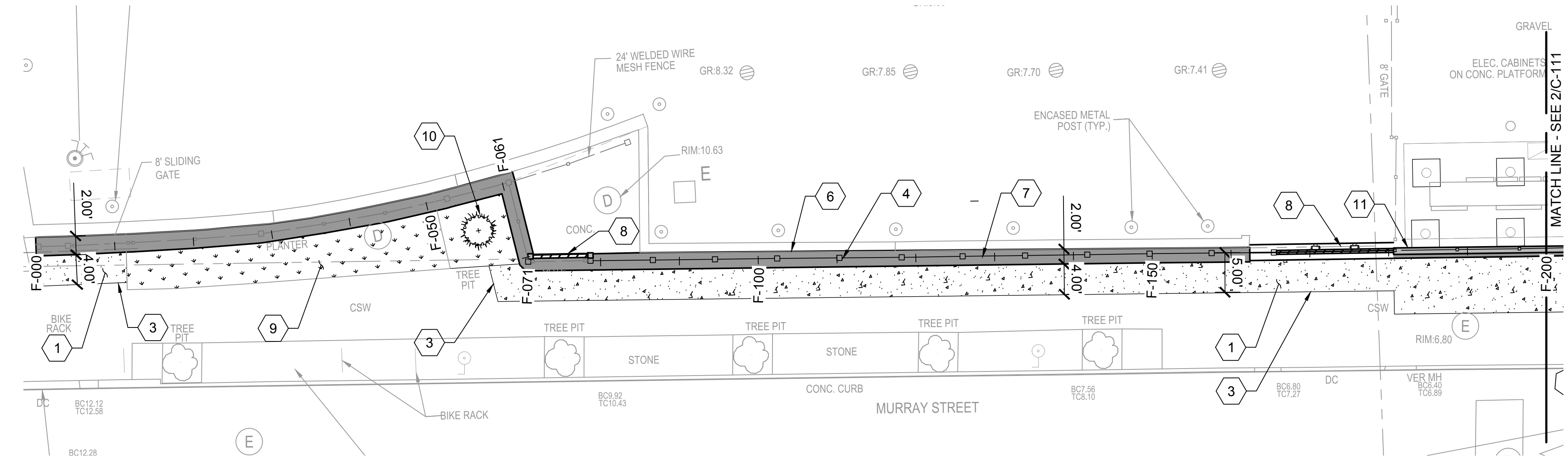

1 SITE LAYOUT PLAN - AREA 1
 C-111 1"=10' 10' 5' 0' 10'

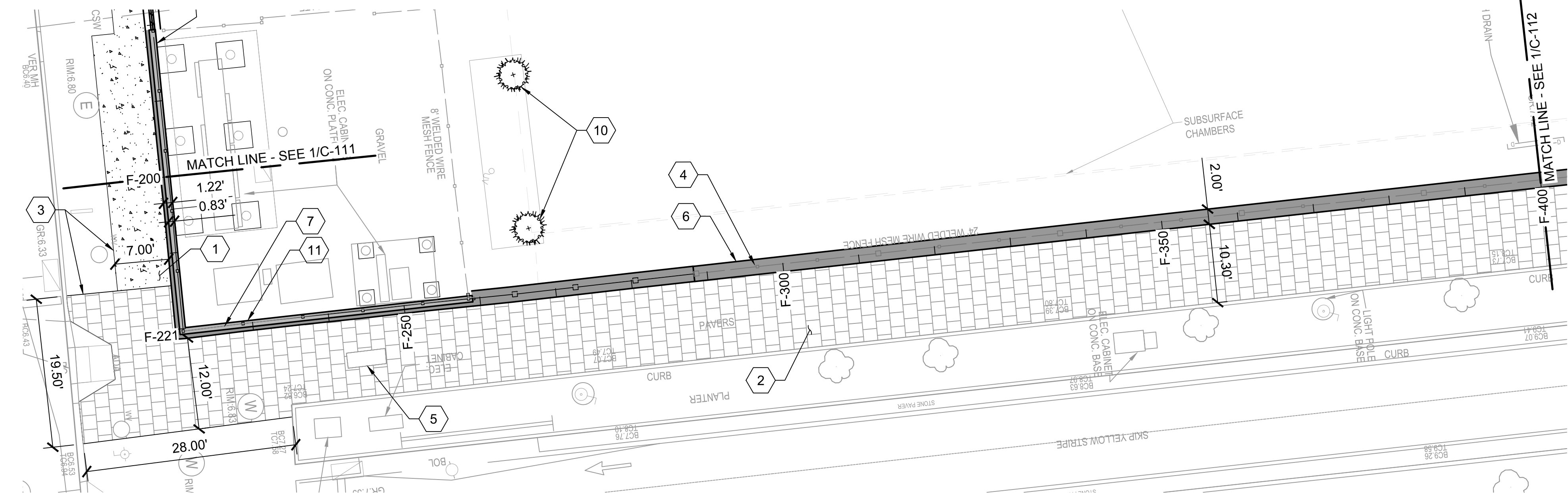

2 SITE LAYOUT PLAN - AREA 2
 C-111 1"=10' 10' 5' 0' 10'

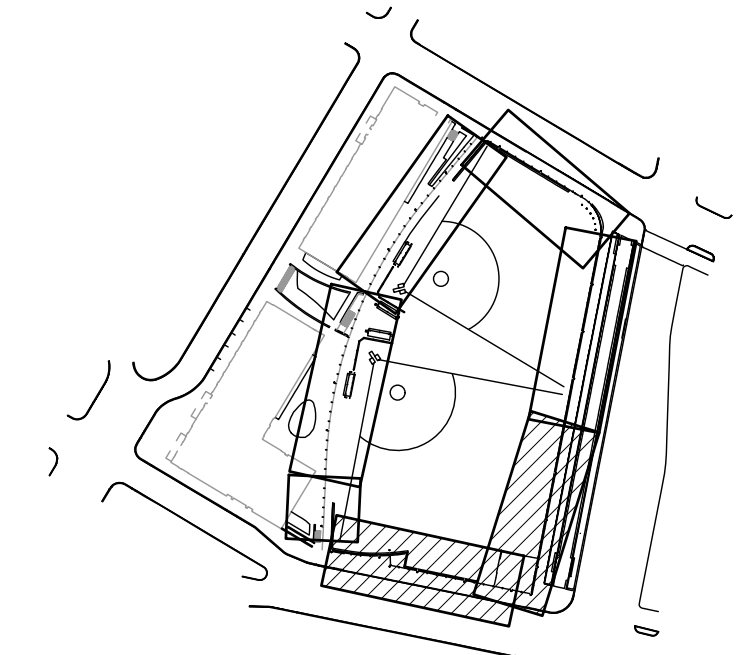

KEY PLAN
 NOT TO SCALE

CONSULTANTS

GENERAL SHEET NOTES

1. REFER TO C-001 AND C-002 FOR CIVIL GENERAL NOTES, LEGEND, AND ABBREVIATIONS.
2. REFER TO LANDSCAPING DRAWINGS FOR ARCHITECTURAL PANEL DETAILS.
3. REFER TO STRUCTURAL DRAWINGS FOR INTERIM FLOOD WALL PLANS, ELEVATIONS, AND DETAILS.

SHEET KEYNOTES

1. FURNISH AND INSTALL NYCDOT STANDARD CONCRETE SIDEWALK. REFER TO DETAIL 1/C-501.
2. FURNISH AND INSTALL PAVERS AND BASE COURSE TO MATCH ADJACENT PAVERS IN NYS DOT RIGHT OF WAY. SEE DETAIL 2/C-501. REUSE EXISTING PAVERS IN GOOD CONDITION OTHERWISE PROVIDE NEW PAVERS TO MATCH.
3. MATCH EXISTING CONCRETE PAVING OR PAVERS.
4. STEEL PLATE FLOOD WALL WITH ARCHITECTURAL PANEL ATTACHED TO EXISTING WELDED WIRE MESH FENCE. REFER TO STRUCTURAL AND LANDSCAPING DRAWINGS FOR DETAILS.
5. REINSTALL SALVAGED CONCRETE BARRIERS.
6. 24" WIDE CONCRETE GRADE BEAM. SEE STRUCTURAL DRAWINGS FOR DETAILS.
7. REINSTALL SALVAGED WELDED WIRE MESH FENCE. SEE STRUCTURAL DRAWINGS FOR DETAILS.
8. FURNISH AND INSTALL FLOOD GATE. REINSTALL SALVAGED SECURITY GATES AT THE ORIGINAL LOCATION AFTER INSTALLATION OF FLOOD GATE.
9. RESTORE LANDSCAPED AREA.
10. INSTALL TREE. SEE LANDSCAPING DRAWINGS FOR DETAILS.
11. 10" WIDE CONCRETE FLOOD WALL. SEE STRUCTURAL DRAWINGS.
12. RESTORE TURF AREA. SEE LANDSCAPING DRAWINGS FOR DETAILS.

SEALS

PROJECT IDENTIFICATION

NEW YORK STATE OF OPPORTUNITY
Battery Park City Authority
 BATTERY PARK CITY
 BALLFIELD AND COMMUNITY CENTER

MARK	DATE	DESCRIPTION	BY
C	11/01/19	ISSUE FOR BID - 95%	ET
B	10/18/19	75% DESIGN SUBMITTAL	SB
A	09/06/19	50% DESIGN SUBMITTAL	SB

ISSUE BLOCK

PROJECT NO.:	3019666
DESIGNED BY:	JA
DRAWN BY:	JA
CHECKED BY:	SB
APPROVED BY:	SB
COPYRIGHT:	STV, INC

SHEET TITLE

SITE LAYOUT PLAN
SHEET 2 OF 2

C-112

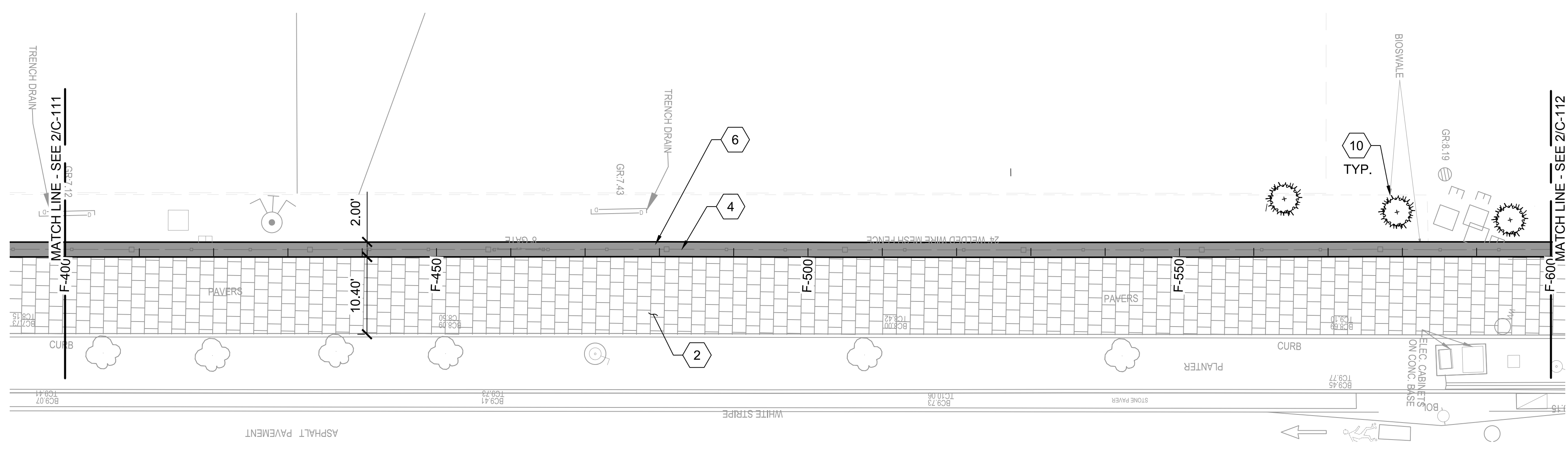

1 SITE LAYOUT PLAN - AREA 3
 C-112 1"=10' 10' 5' 0' 10'

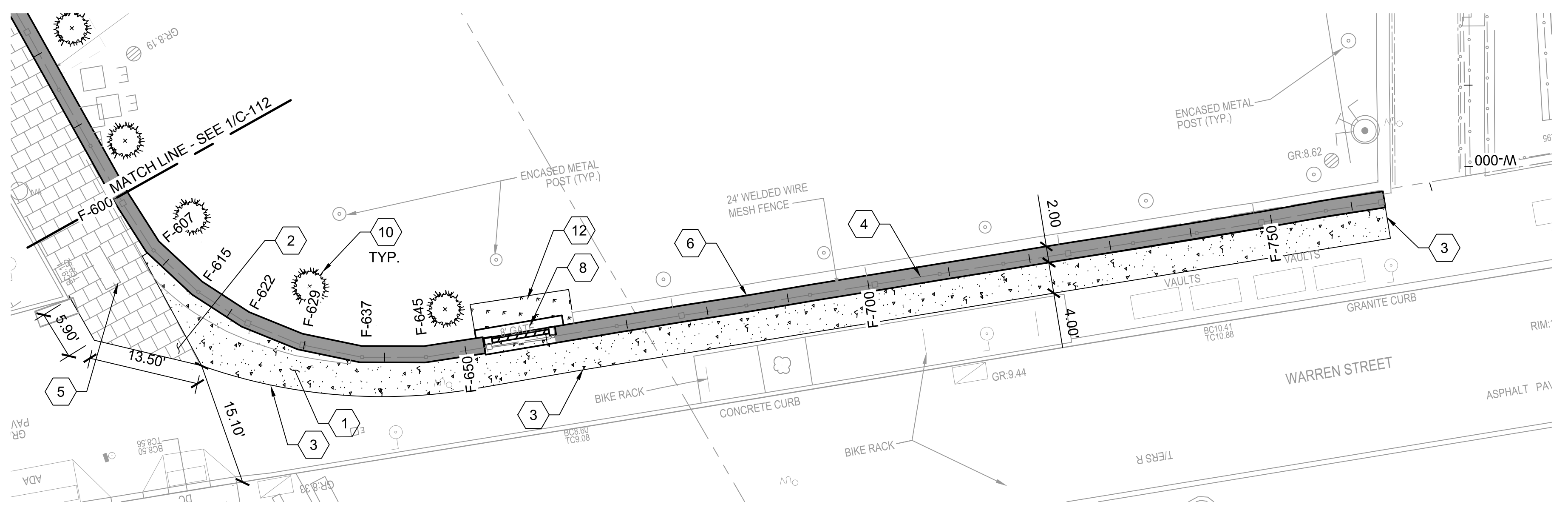

2 SITE LAYOUT PLAN - AREA 4
 C-112 1"=10' 10' 5' 0' 10'

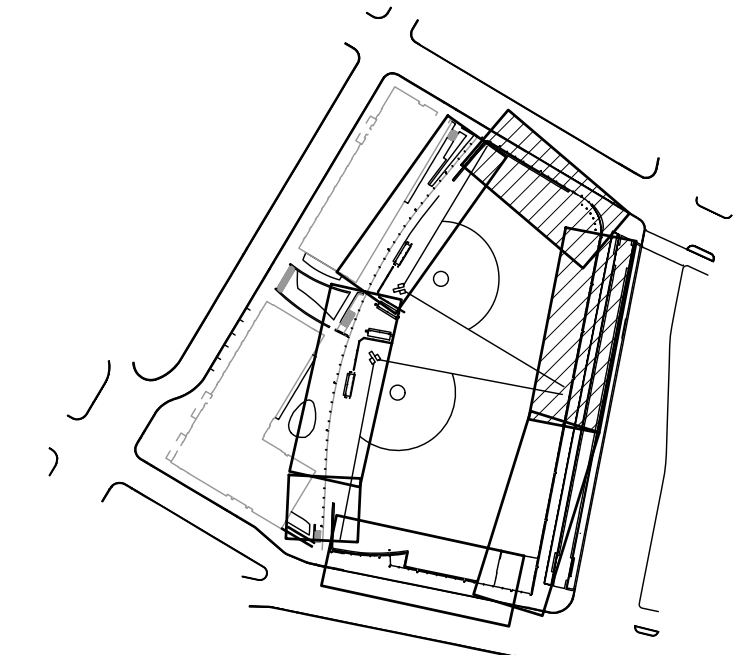

KEY PLAN
 NOT TO SCALE

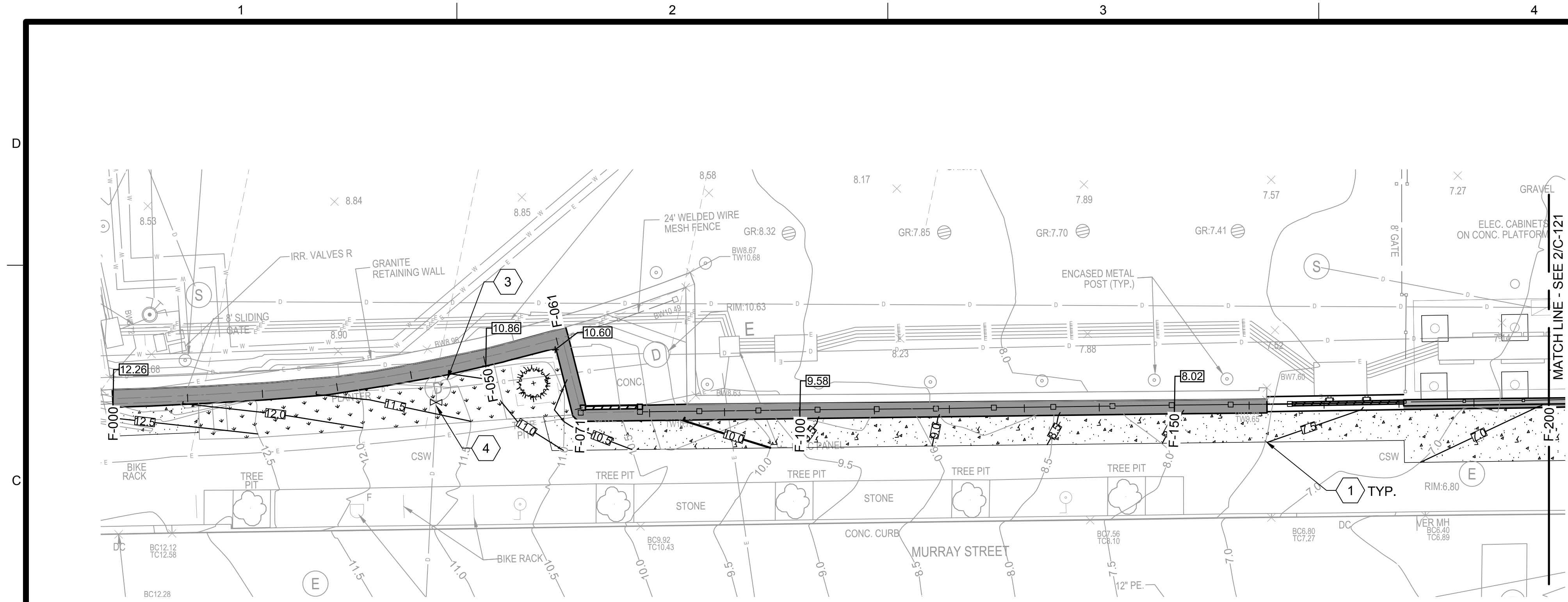

1 GRADING, DRAINAGE, AND UTILITY PLAN - AREA 1
 C-121 1"=10' 0 5 10'

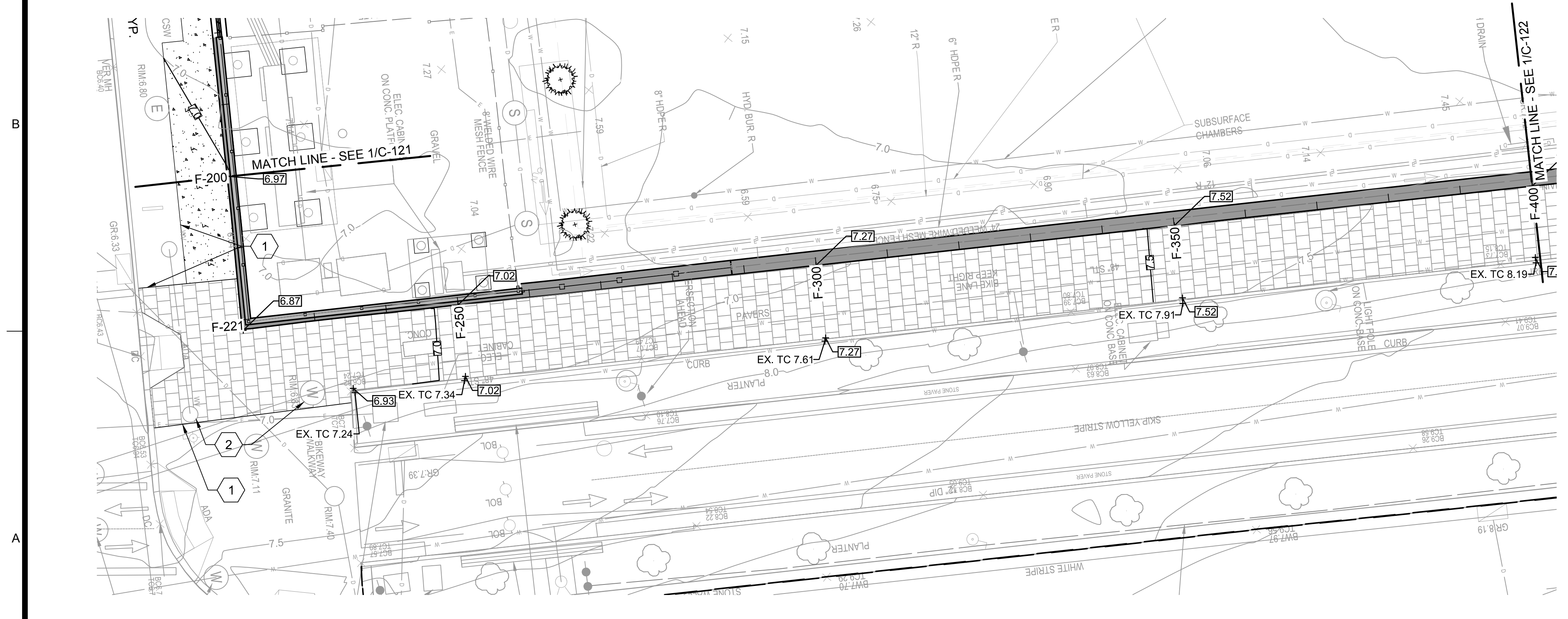

2 GRADING, DRAINAGE, AND UTILITY PLAN - AREA 2
 C-121 1"=10' 0 5 10'

GENERAL SHEET NOTES

- REFER TO C-001 AND C-002 FOR CIVIL GENERAL NOTES, LEGEND, AND ABBREVIATIONS.
- REFER TO GENERAL NOTES FOR HORIZONTAL COORDINATES AND ELEVATION DATUM.
- REFER TO LANDSCAPING DRAWINGS FOR ARCHITECTURAL PANEL DETAILS.
- REFER TO STRUCTURAL DRAWINGS FOR FLOOD WALL PLANS, ELEVATIONS, AND DETAILS.

SHEET KEYNOTES

- MATCH EXISTING GRADE.
- RESET EXISTING STRUCTURE TO FINISH GRADE ELEVATION.
- PROVIDE HEAVY DUTY WATERTIGHT MANHOLE COVER TO WITHSTAND DESIGN FLOOD LOAD.
- INSTALL INLINE CHECK VALVE ON OUTGOING 15" DUCTILE IRON PIPE WITHIN BPC PROPERTY LINE. SIZE AND INVERT OF PIPE SHALL BE VERIFIED IN FIELD.
- SEAL EXISTING ELECTRICAL CONDUITS IN CON EDISON VAULTS BELOW THE DFE. COORDINATE WITH CON EDISON.

STV 100 Years
 STV INCORPORATED
 225 PARK AVENUE SOUTH
 5TH FLOOR
 NEW YORK, NY 10003
 www.stvinc.com

CONSULTANTS
SITWORKS
 LANDSCAPE ARCHITECTURE, LLC
 150 WEST 28TH STREET
 SUITE 605
 NEW YORK, NY 10001
 www.sitworkscom.com

SEALS

PROJECT IDENTIFICATION
 NEW YORK STATE OF OPPORTUNITY
Battery Park City Authority
 BATTERY PARK CITY
 BALLFIELD AND COMMUNITY CENTER

MARK	DATE	DESCRIPTION	BY
C	11/01/19	ISSUE FOR BID - 95%	ET
B	10/18/19	75% DESIGN SUBMITTAL	SB
A	09/06/19	50% DESIGN SUBMITTAL	SB

ISSUE BLOCK

PROJECT NO.:	3019666
DESIGNED BY:	JA
DRAWN BY:	JA
CHECKED BY:	SB
APPROVED BY:	SB
COPYRIGHT:	STV, INC

SHEET TITLE
GRADING, DRAINAGE, AND UTILITY PLAN
 SHEET 1 OF 2

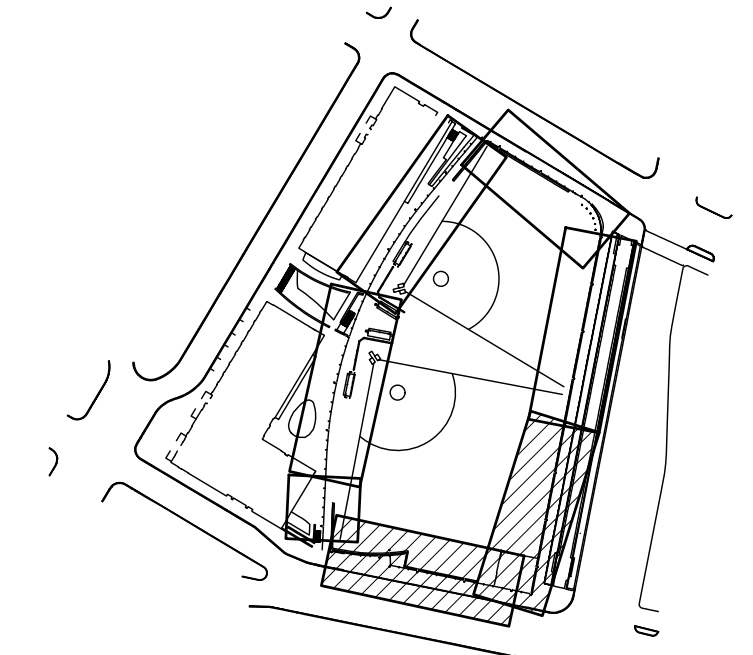

KEY PLAN
 NOT TO SCALE

C-121

GENERAL SHEET NOTES

- REFER TO C-001 AND C-002 FOR CIVIL GENERAL NOTES, LEGEND, AND ABBREVIATIONS.
- REFER TO GENERAL NOTES FOR HORIZONTAL COORDINATES AND ELEVATION DATUM.
- REFER TO LANDSCAPING DRAWINGS FOR ARCHITECTURAL PANEL DETAILS.
- REFER TO STRUCTURAL DRAWINGS FOR FLOOD WALL PLANS, ELEVATIONS, AND DETAILS.

SHEET KEYNOTES

- MATCH EXISTING GRADE.
- RESET EXISTING STRUCTURE TO FINISH GRADE ELEVATION.
- PROVIDE HEAVY DUTY WATERTIGHT MANHOLE COVER TO WITHSTAND DESIGN FLOOD LOAD.
- INSTALL INLINE CHECK VALVE ON OUTGOING 15" DUCTILE IRON PIPE WITHIN BPC PROPERTY LINE. SIZE AND INVERT OF PIPE SHALL BE VERIFIED IN FIELD.
- SEAL EXISTING ELECTRICAL CONDUITS IN CON EDISON VAULTS BELOW THE DFE. COORDINATE WITH CON EDISON.

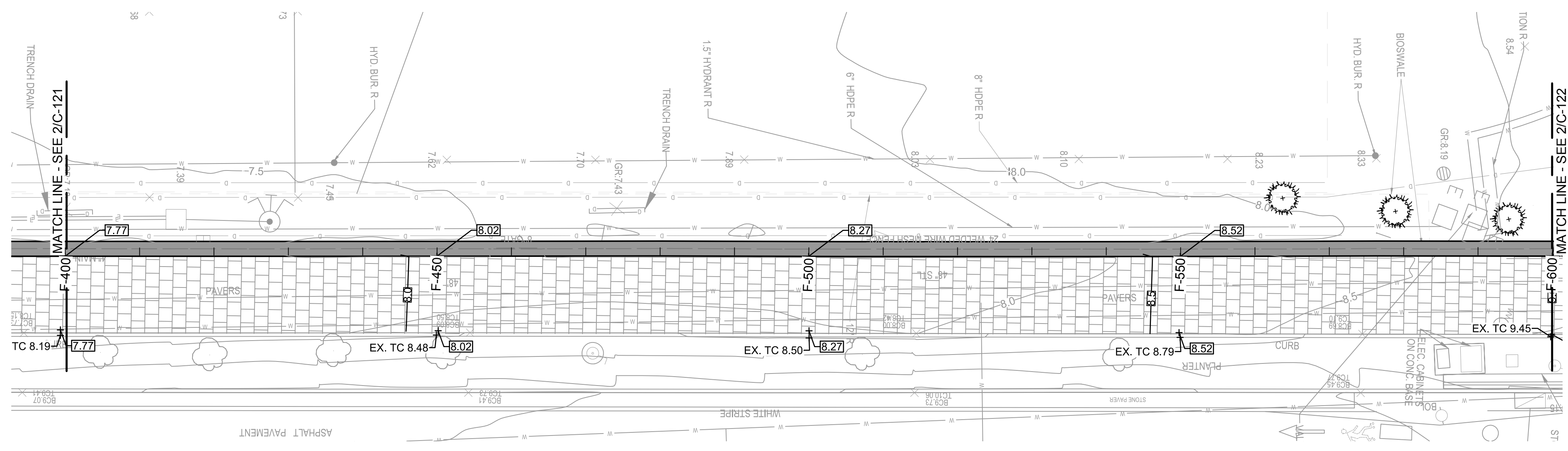

1 GRADING, DRAINAGE, AND UTILITY PLAN - AREA 3
 1"=10' 10' 5' 0' 10'

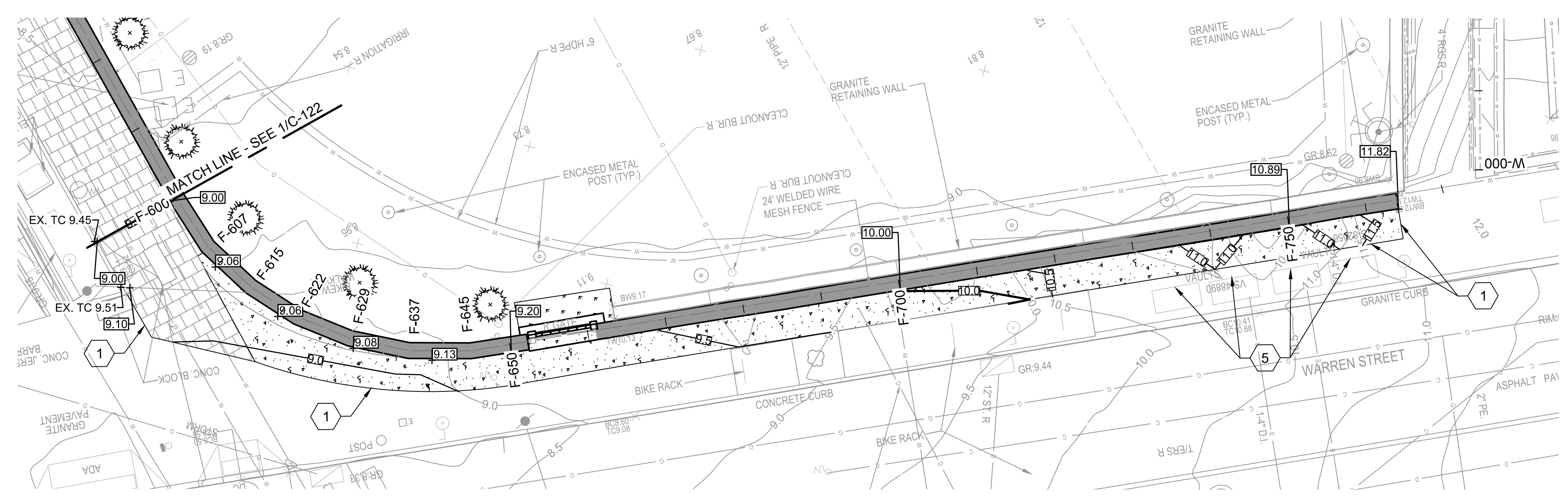

2 GRADING, DRAINAGE, AND UTILITY PLAN - AREA 4
 1"=10' 10' 5' 0' 10'

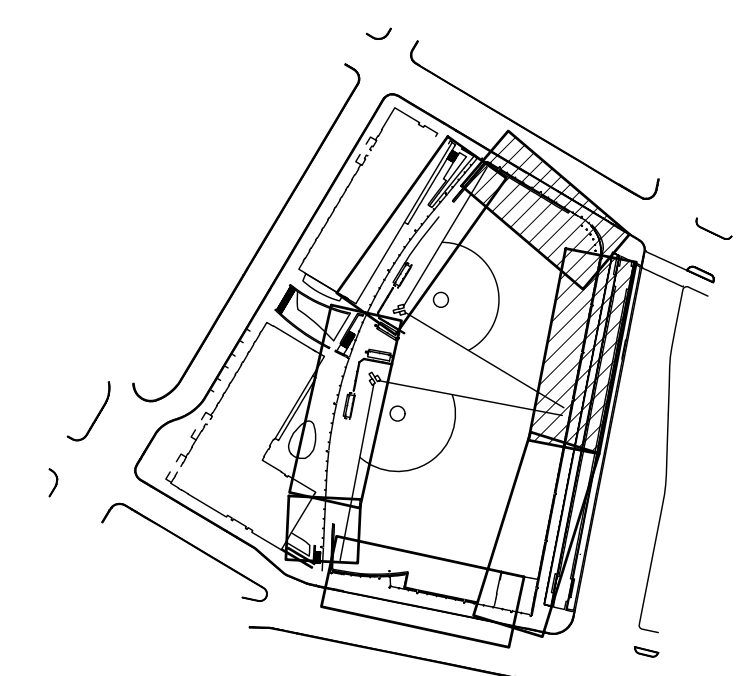

SEALS

PROJECT IDENTIFICATION

NEW YORK STATE OF OPPORTUNITY
Battery Park City Authority
 BATTERY PARK CITY
 BALLFIELD AND COMMUNITY CENTER

MARK	DATE	DESCRIPTION	BY
C	11/01/19	ISSUE FOR BID - 95%	ET
B	10/18/19	75% DESIGN SUBMITTAL	SB
A	09/06/19	50% DESIGN SUBMITTAL	SB

ISSUE BLOCK

PROJECT NO.: 3019666
 DESIGNED BY: JA
 DRAWN BY: JA
 CHECKED BY: SB
 APPROVED BY: SB
 COPYRIGHT: STV, INC

SHEET TITLE
**GRADING,
 DRAINAGE, AND
 UTILITY PLAN
 SHEET 2 OF 2**

C-122

CONSULTANTS

SITWORKS
 LANDSCAPE ARCHITECTURE, LLC
 150 WEST 28TH STREET
 SUITE 605
 NEW YORK, NY 10001
 www.sitworks.com

GENERAL SHEET NOTES

1. REFER TO C-001 AND C-002 FOR CIVIL GENERAL NOTES, LEGEND, AND ABBREVIATIONS.
2. SEE G-003 FOR TREE PROTECTION PLAN.
3. THIS PLAN IS INTENDED TO SERVE AS A GUIDE FOR EROSION AND SEDIMENT CONTROL MEASURES. THE CONTRACTOR SHALL PROVIDE AN EROSION AND SEDIMENT CONTROL PLAN IN CONJUNCTION WITH PHASING AND LOGISTICS PLAN FOR APPROVAL PRIOR TO CONSTRUCTION START.

SHEET KEYNOTES

1. TREE PROTECTION. SEE LANDSCAPING DRAWINGS FOR DETAILS.
2. INLET PROTECTION. SEE DETAIL 1/C-502.
3. CONSTRUCTION FENCE. FENCE WITHIN TURF AREAS SHALL NOT DAMAGE EXISTING TURF TO REMAIN.
4. SEDIMENT FILTER LOG. SEE DETAIL 3/C-502.
5. STOCKPILE. SEE DETAIL 2/C-502.
6. STABILIZED CONSTRUCTION ENTRANCE. SEE DETAIL 5/C-502.

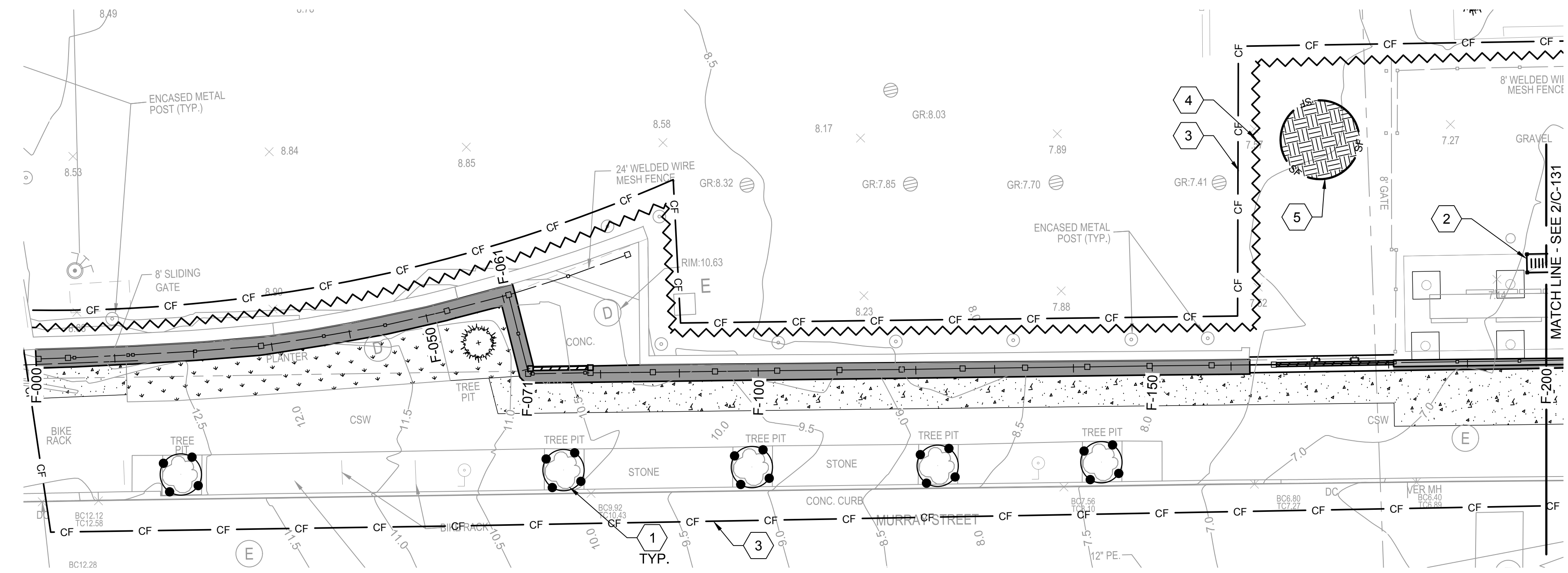

1 EROSION AND SEDIMENT CONTROL PLAN - AREA 1
 C-131 1"=10'
 10' 5' 0 10'

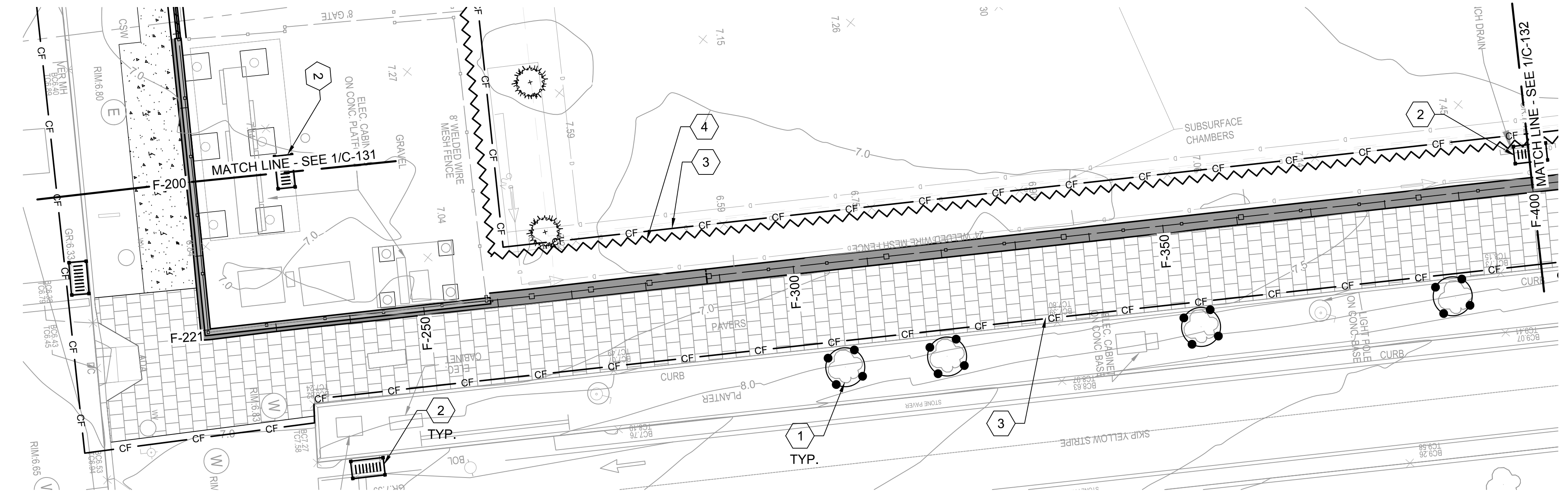

2 EROSION AND SEDIMENT CONTROL PLAN - AREA 2
 C-131 1"=10'
 10' 5' 0 10'

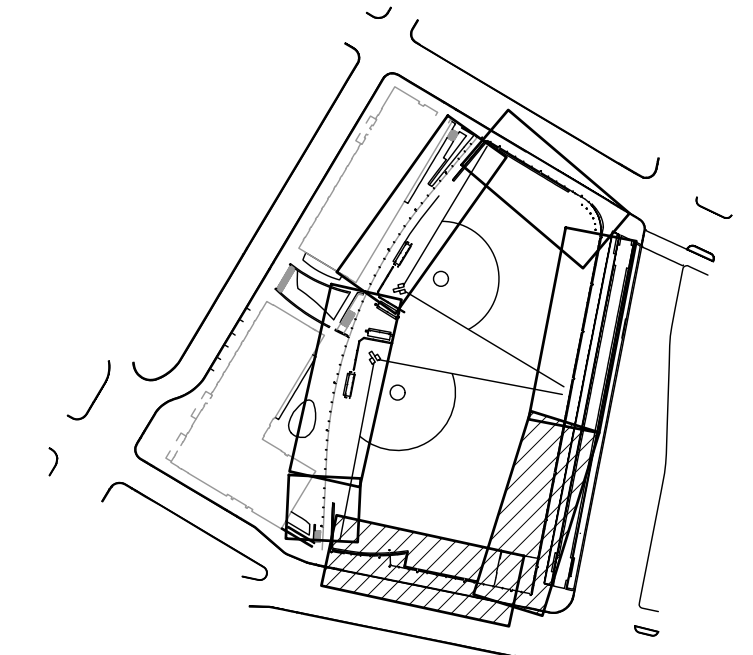

KEY PLAN
 NOT TO SCALE

SEALS

PROJECT IDENTIFICATION

NEW YORK STATE OF OPPORTUNITY
Battery Park City Authority
 BATTERY PARK CITY
 BALLFIELD AND COMMUNITY CENTER

MARK	DATE	DESCRIPTION	BY
C	11/01/19	ISSUE FOR BID - 95%	ET
B	10/18/19	75% DESIGN SUBMITTAL	SB
A	09/06/19	50% DESIGN SUBMITTAL	SB

ISSUE BLOCK

PROJECT NO.:	3019666
DESIGNED BY:	JA
DRAWN BY:	JA
CHECKED BY:	SB
APPROVED BY:	SB
COPYRIGHT:	STV, INC

SHEET TITLE
EROSION AND SEDIMENT CONTROL PLAN
SHEET 1 OF 2

C-131

GENERAL SHEET NOTES

1. REFER TO C-001 AND C-002 FOR CIVIL GENERAL NOTES, LEGEND, AND ABBREVIATIONS.
2. SEE G-003 FOR TREE PROTECTION PLAN.
3. THIS PLAN IS INTENDED TO SERVE AS A GUIDE FOR EROSION AND SEDIMENT CONTROL MEASURES. THE CONTRACTOR SHALL PROVIDE AN EROSION AND SEDIMENT CONTROL PLAN IN CONJUNCTION WITH PHASING AND LOGISTICS PLAN FOR APPROVAL PRIOR TO CONSTRUCTION START.

SHEET KEYNOTES

1. TREE PROTECTION. SEE LANDSCAPING DRAWINGS FOR DETAILS.
2. INLET PROTECTION. SEE DETAIL 1/C-502.
3. CONSTRUCTION FENCE. FENCE WITHIN TURF AREAS SHALL NOT DAMAGE EXISTING TURF TO REMAIN.
4. SEDIMENT FILTER LOG. SEE DETAIL 3/C-502.
5. STOCKPILE. SEE DETAIL 2/C-502.
6. STABILIZED CONSTRUCTION ENTRANCE. SEE DETAIL 5/C-502.

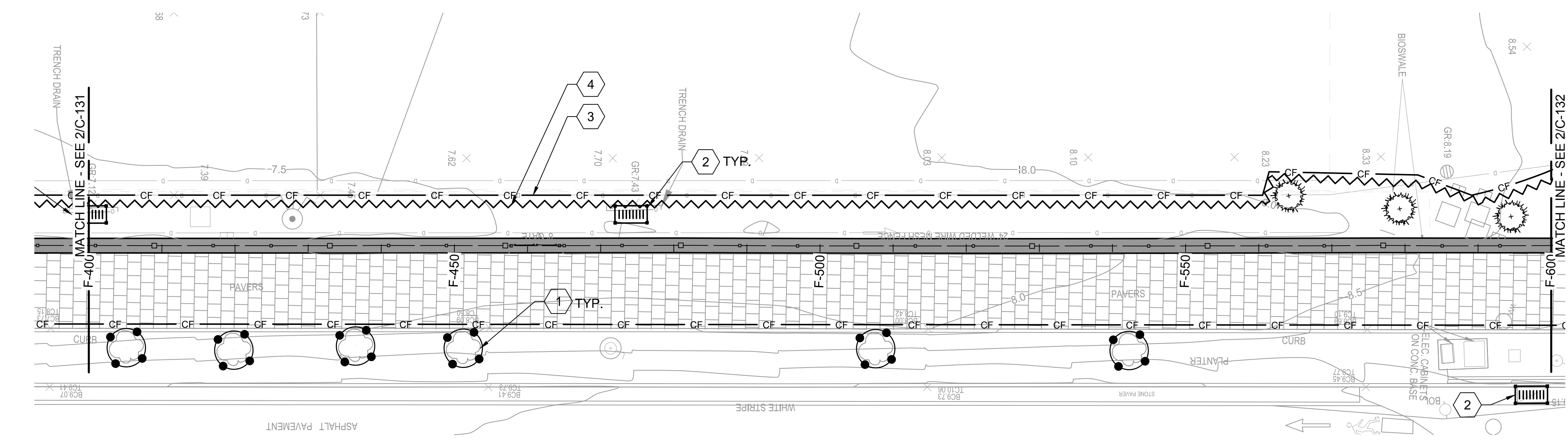

1 EROSION AND SEDIMENT CONTROL PLAN - AREA 3
 C-132 1"=10'
 10' 5' 0' 10'

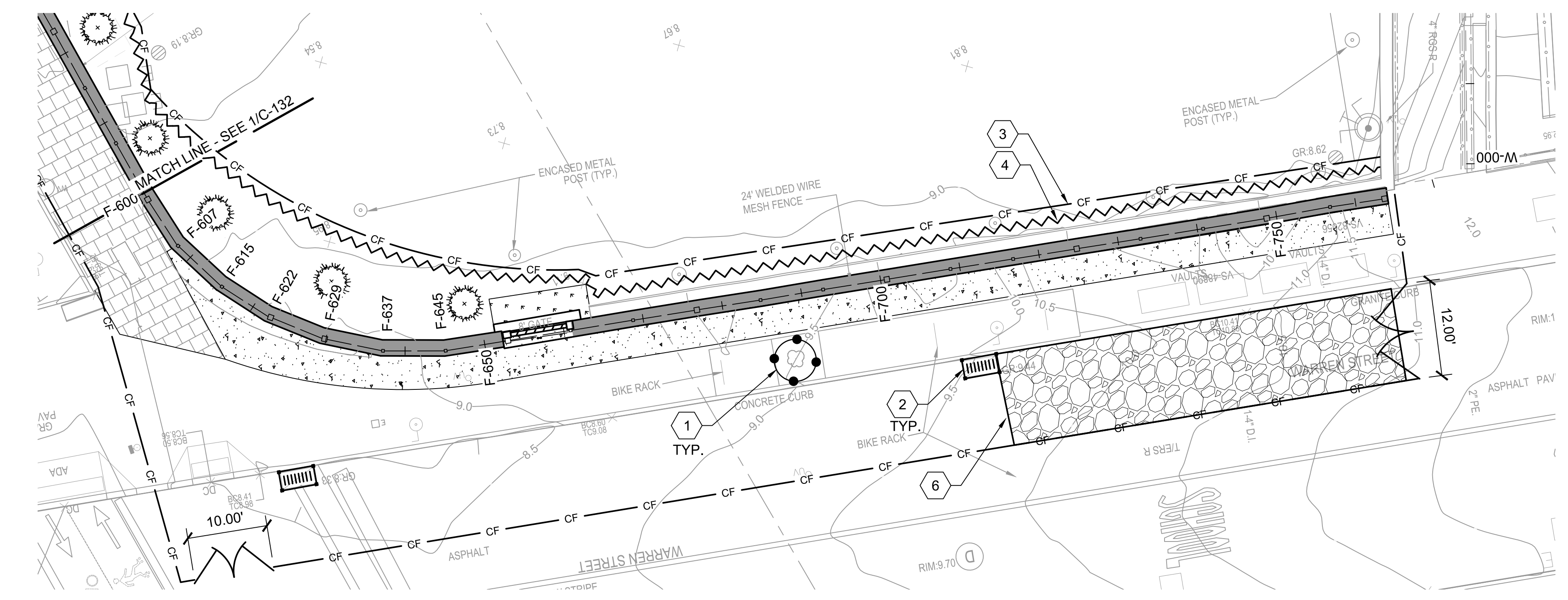

2 EROSION AND SEDIMENT CONTROL PLAN - AREA 4
 C-132 1"=10'
 10' 5' 0' 10'

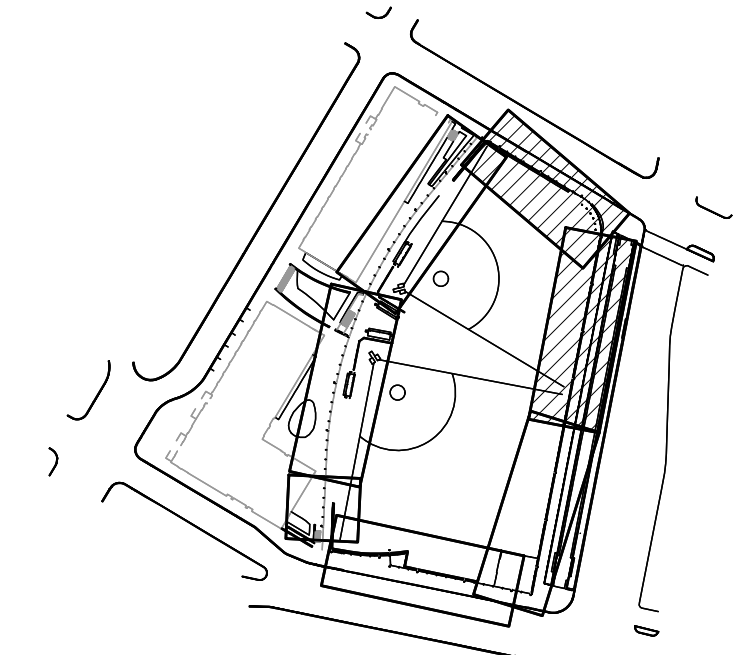

SEALS

PROJECT IDENTIFICATION
 NEW YORK STATE OF OPPORTUNITY
Battery Park City Authority
 BATTERY PARK CITY
 BALLFIELD AND COMMUNITY CENTER

MARK	DATE	DESCRIPTION	BY
C	11/01/19	ISSUE FOR BID - 95%	ET
B	10/18/19	75% DESIGN SUBMITTAL	SB
A	09/06/19	50% DESIGN SUBMITTAL	SB

ISSUE BLOCK

PROJECT NO.:	3019666
DESIGNED BY:	JA
DRAWN BY:	JA
CHECKED BY:	SB
APPROVED BY:	SB
COPYRIGHT:	STV, INC

SHEET TITLE
EROSION AND SEDIMENT CONTROL PLAN
 SHEET 2 OF 2

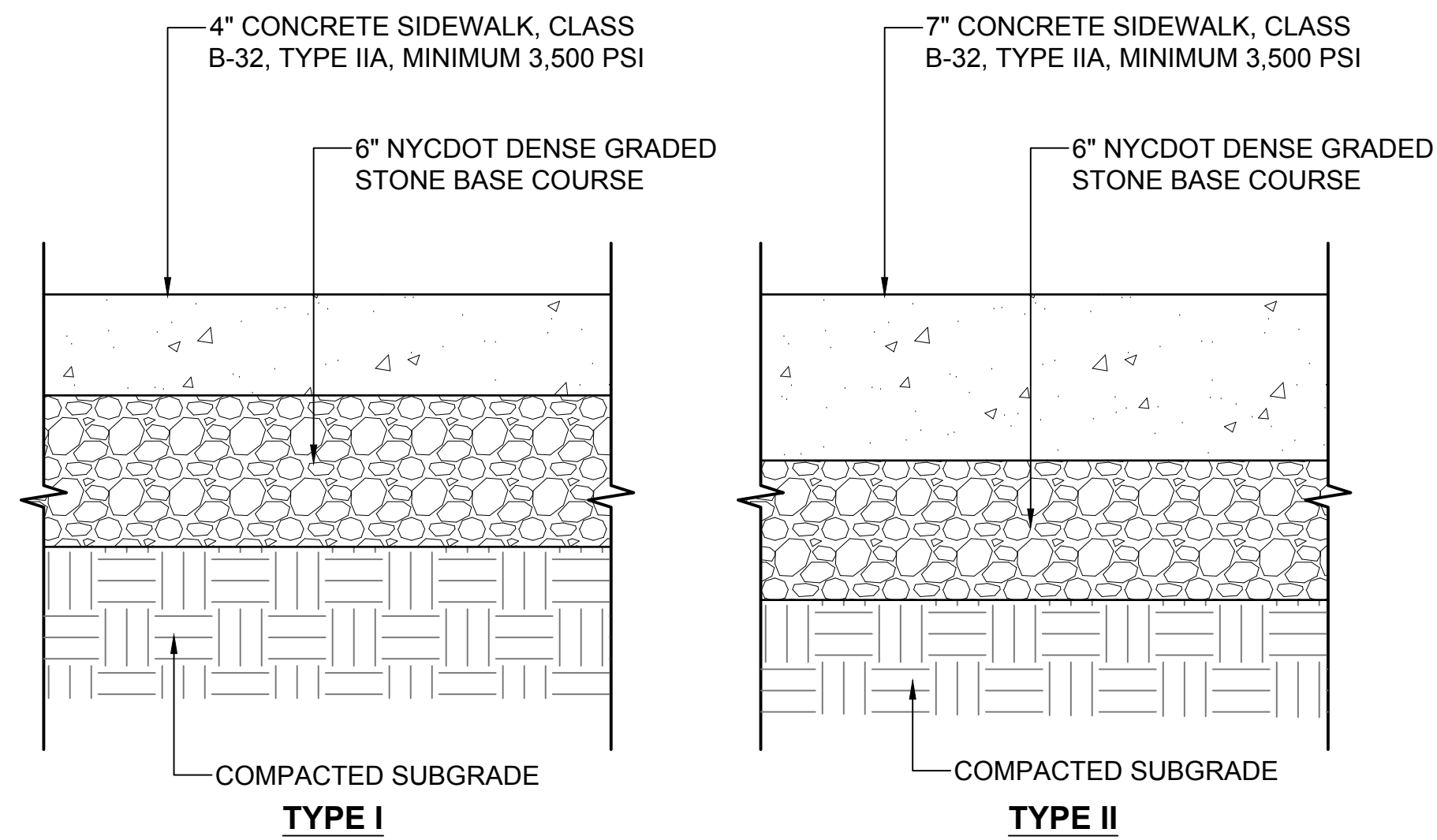

NOTE:

1. ALL MATERIALS AND CONSTRUCTION METHODS USED ARE TO CONFORM TO SECTION #4.13 OF THE LATEST NYC DEPARTMENT OF TRANSPORTATION (DOT) STANDARD HIGHWAY SPECIFICATIONS AND STANDARD DETAIL H-1045.
2. TYPE II CONCRETE SIDEWALK SHALL BE USED IN DRIVEWAYS AND CORNER QUADRANTS.

1 NYC DOT CONCRETE SIDEWALK NTS

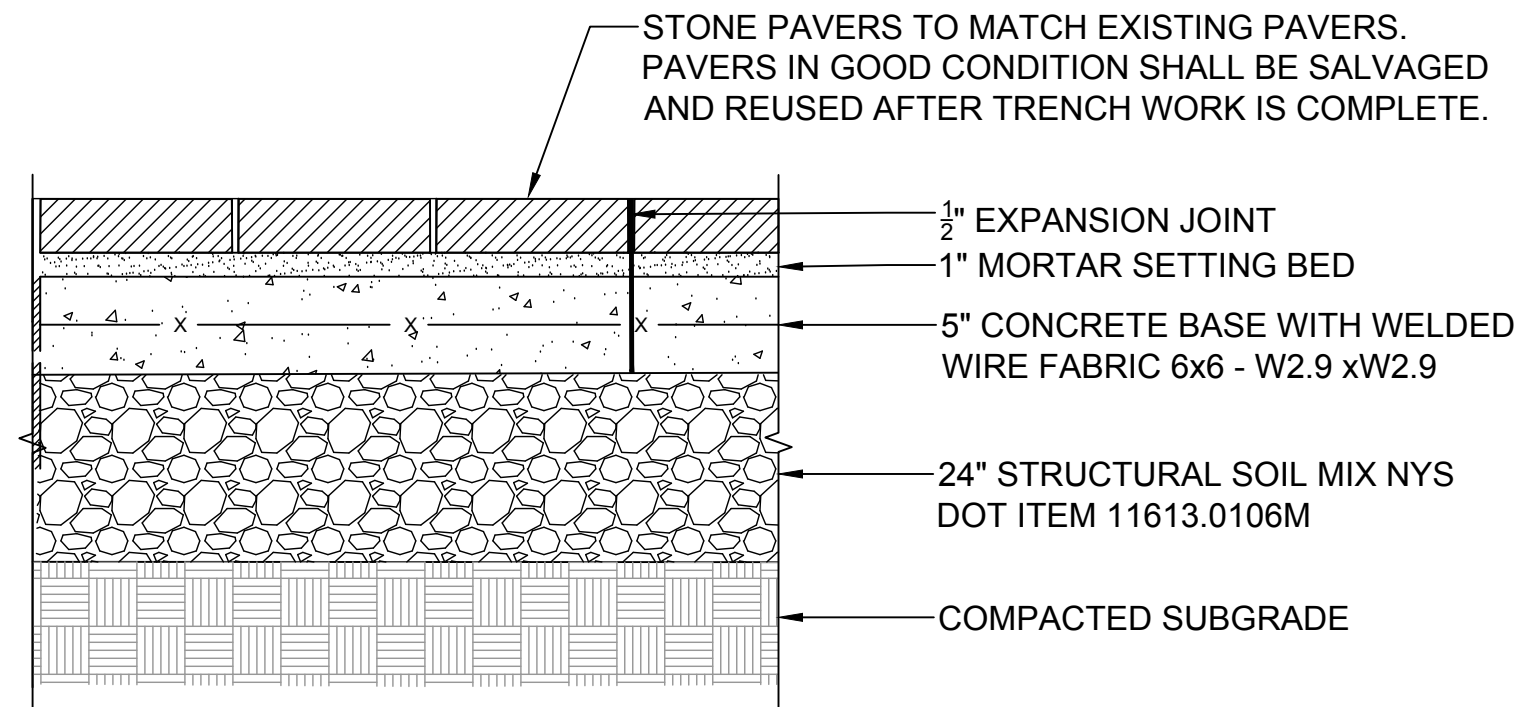

NOTE:

1. ALL STONE PAVER RESTORATION SHALL MEET THE LATEST NYS DOT STANDARDS AND SPECIFICATIONS.
2. PAVERS SHALL MATCH THE STYLE, COLOR, AND SIZE OF ADJACENT EXISTING PAVERS IN THE NYS DOT RIGHT OF WAY.
3. EXISTING PAVER SUBBASE IS UNKNOWN. CONTRACTOR SHALL VERIFY THE EXISTING SUBBASE CONDITIONS AND NOTIFY THE ENGINEER.
4. FULL DEPTH PAVER RESTORATION MAY NOT BE REQUIRED IN AREAS WITH LITTLE OR NO GRADE CHANGE.

2 PAVER RESTORATION NTS



STV INCORPORATED
225 PARK AVENUE SOUTH
5TH FLOOR
NEW YORK, NY 10003
www.stvinc.com

CONSULTANTS

SITWORKS
LANDSCAPE ARCHITECTURE, LLC
150 WEST 28TH STREET
SUITE 605
NEW YORK, NY 10001
www.siteworkscm.com

SEALS

PROJECT IDENTIFICATION

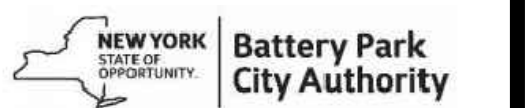

BATTERY PARK CITY
BALLFIELD AND COMMUNITY
CENTER

MARK	DATE	DESCRIPTION	BY
C	11/01/19	ISSUE FOR BID - 95%	ET
B	10/18/19	75% DESIGN SUBMITTAL	SB
A	09/06/19	50% DESIGN SUBMITTAL	SB

ISSUE BLOCK

PROJECT NO.:	3019666
DESIGNED BY:	JA
DRAWN BY:	JA
CHECKED BY:	SB
APPROVED BY:	SB
COPYRIGHT:	STV, INC

SHEET TITLE

SITE DETAILS

C-501

MARK	DATE	DESCRIPTION	BY
C	11/01/19	ISSUE FOR BID - 95%	SB
B	10/18/19	75% DESIGN SUBMITTAL	ET
	09/06/19	50% DESIGN SUBMITTAL	SB

ISSUE BLOCK

PROJECT NO.:	3019666
DESIGNED BY:	JA
DRAWN BY:	JA
CHECKED BY:	SB
APPROVED BY:	SB
COPYRIGHT:	STV, INC

SHEET TITLE
**EROSION AND
 SEDIMENT
 CONTROL
 DETAILS**

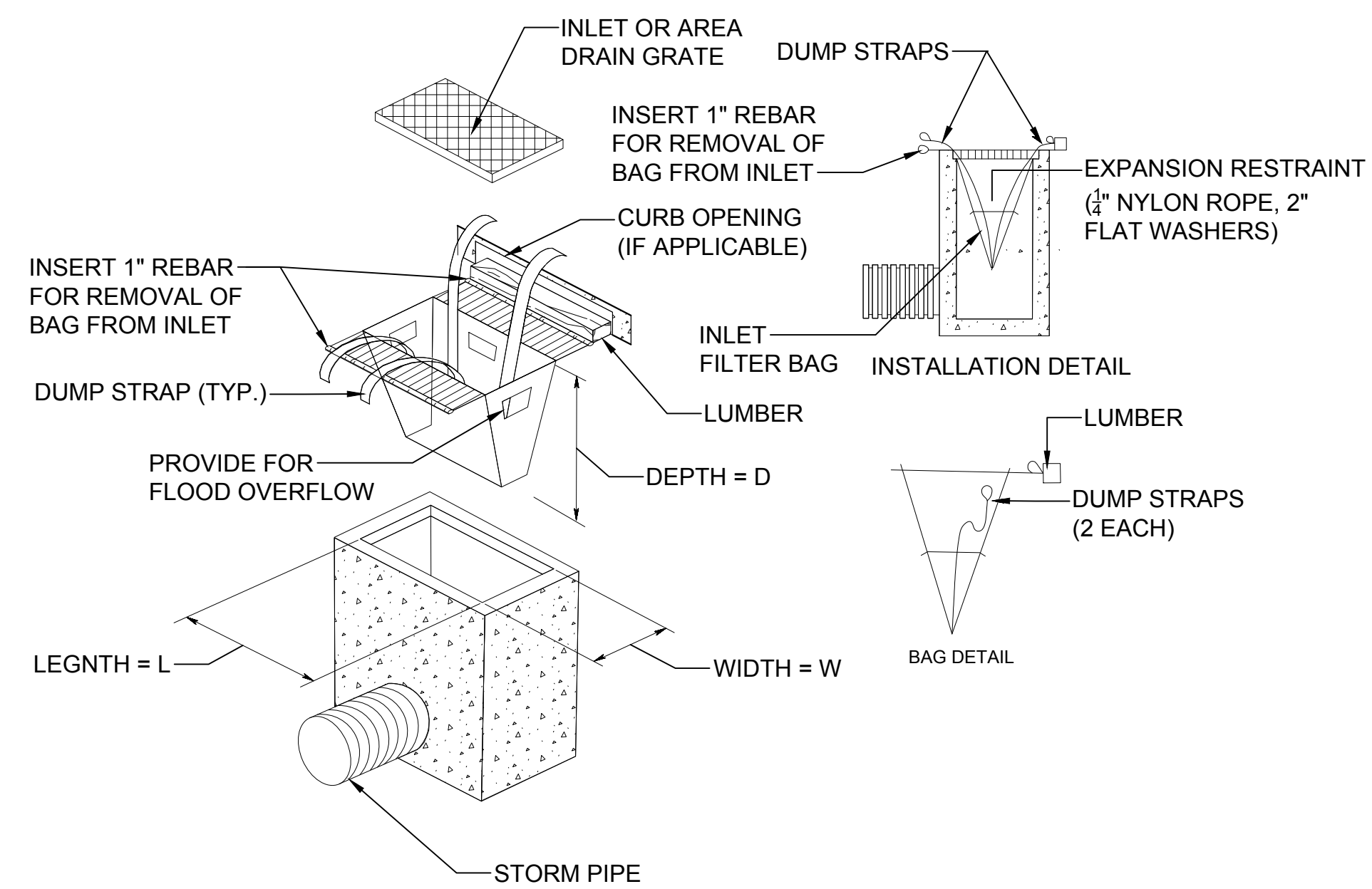

1 DROP INLET PROTECTION NTS

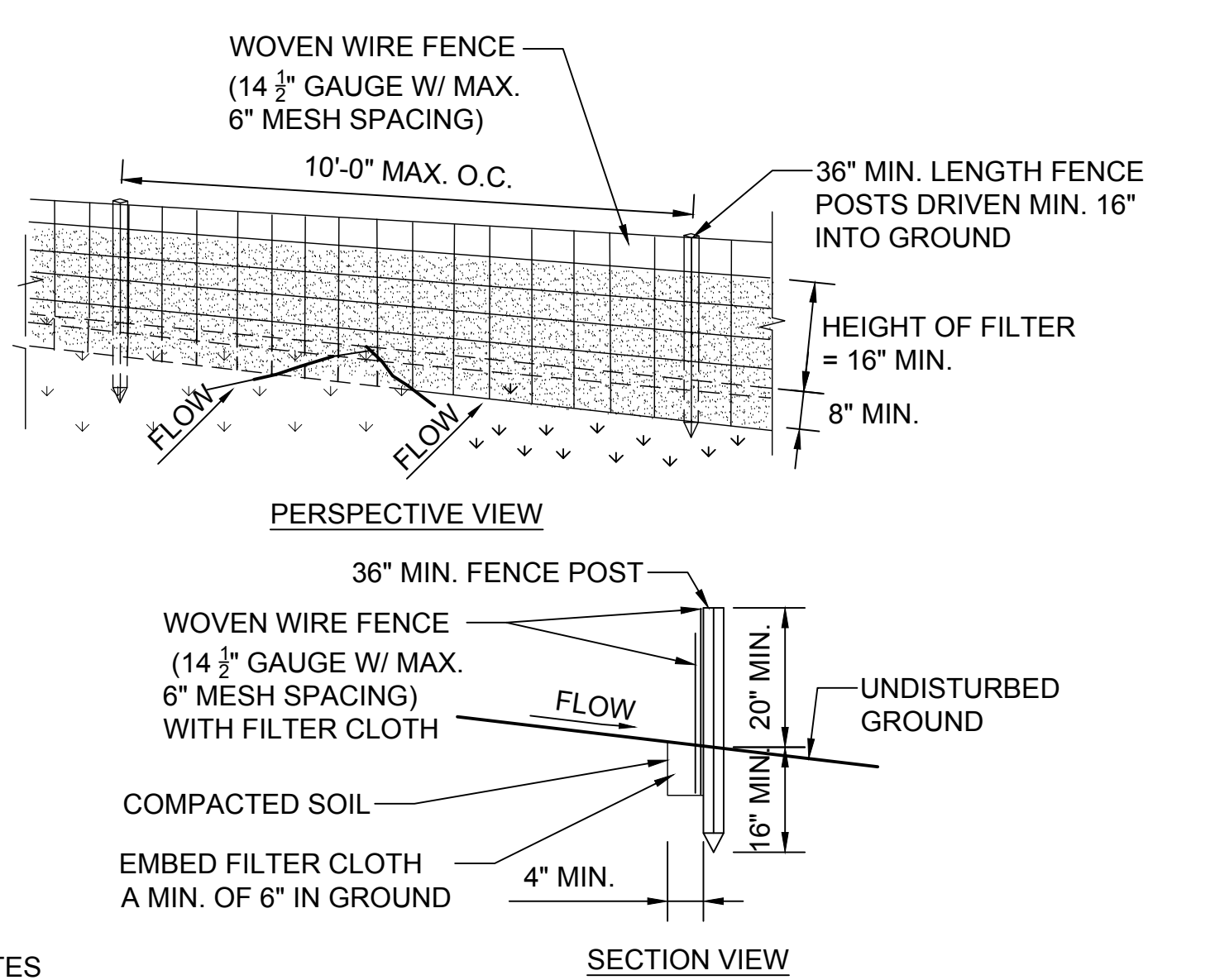

- NOTES**
- SILT FENCE SHALL BE INSTALLED AT LEVEL GRADE. BOTH ENDS OF EACH FENCE SECTION SHALL BE EXTENDED AT LEAST 8 FEET UPSLOPE AT 45 DEGREES TO THE MAIN FENCE ALIGNMENT.
 - WOVEN WIRE FENCE TO BE FASTENED SECURELY TO FENCE POSTS WITH WIRE TIES OR STAPLES. POSTS SHALL BE STEEL EITHER "T" OR "U" TYPE OR HARDWOOD.
 - FILTER CLOTH SHALL BE FASTENED SECURELY TO WOVEN WIRE FENCE WITH TIES SPACED EVERY 24" AT TOP AND MID SECTION. FENCE SHALL BE WOVEN WIRE 14 1/2" GAUGE, 6" MAXIMUM MESH OPENING.
 - WHERE ENDS OF GEOTEXTILE FABRIC COME TOGETHER, THE FABRIC SHALL BE OVERLAPPED, FOLDED, AND STAPLED TO PREVENT SEDIMENT BYPASS. THE FENCE FABRIC SHALL BE ANCHORED AT THE TOE THEN BACKFILLED AND COMPACTED TO A DENSITY EQUAL TO THE SURROUNDING SOILS.
 - SEDIMENT SHALL BE REMOVED WHEN ACCUMULATIONS REACH 1/2 THE ABOVE GROUND HEIGHT OF THE FENCE.
 - GEOTEXTILE FABRIC SHALL BE AS SPECIFIED IN THE LATEST NEW YORK STATE STANDARDS AND SPECIFICATIONS FOR EROSION AND SEDIMENT CONTROL.

4 SILT FENCE NTS

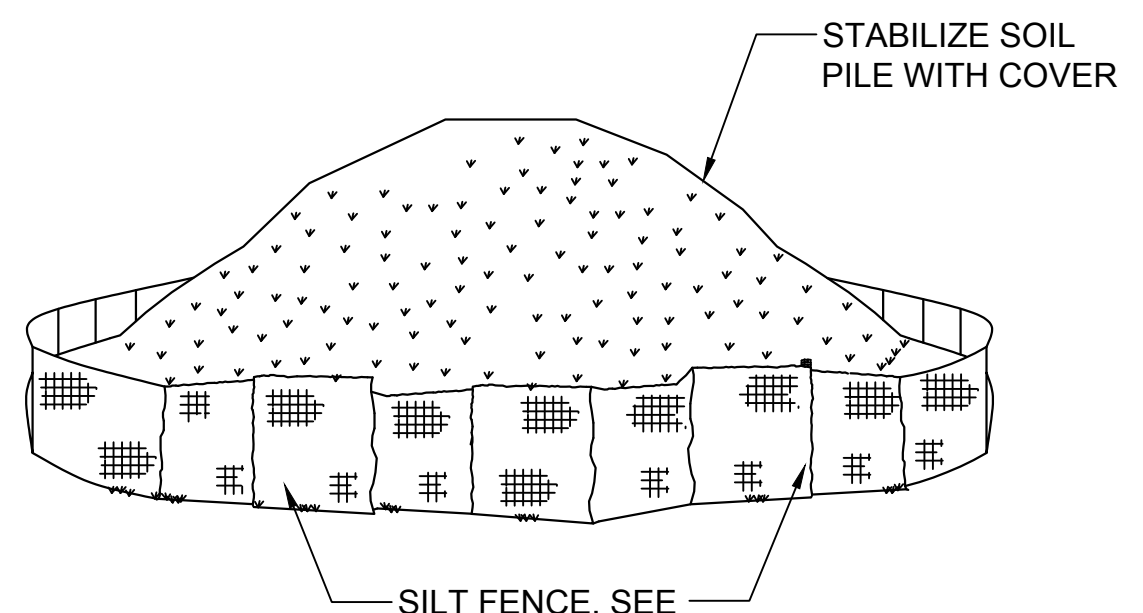

- NOTES**
- AREA CHOSEN FOR STOCKPILING OPERATIONS SHALL BE DRY AND STABLE.
 - MAXIMUM SLOPE OF STOCKPILE SHALL BE 2H:1V
 - UPON COMPLETION OF SOIL STOCKPILING, EACH PILE SHALL BE SURROUNDED WITH SILT FENCING.
 - A MINIMUM OF 12" MUST BE MAINTAINED BETWEEN THE TOE OF THE STOCKPILE AND THE EDGE OF THE FENCE ON ALL SIDES.
 - THE GROUND SURFACE WHERE SOIL WILL BE STOCKPILED SHALL BE COVERED WITH A MINIMUM OF 0.25 MM OR 2 LAYERS OF 0.15 MM POLYETHYLENE SHEETING OR AN APPROVED EQUAL MATERIAL.
 - PRIOR TO THE END OF EACH WORK DAY, STOCKPILES SHALL BE COMPLETELY COVERED WITH THE POLYETHYLENE SHEETING. STOCK PILE COVERS SHALL BE WEIGHTED OR SECURED BY APPROPRIATE MEANS. ALL SEAMS SHALL BE OVERLAPPED AND SEALED. DAMAGED COVERED SHALL BE REPAIRED OR REPLACED BY THE CONTRACTOR WITHIN 24 HOURS AFTER NOTIFICATION.

2 SOIL STOCKPILING NTS

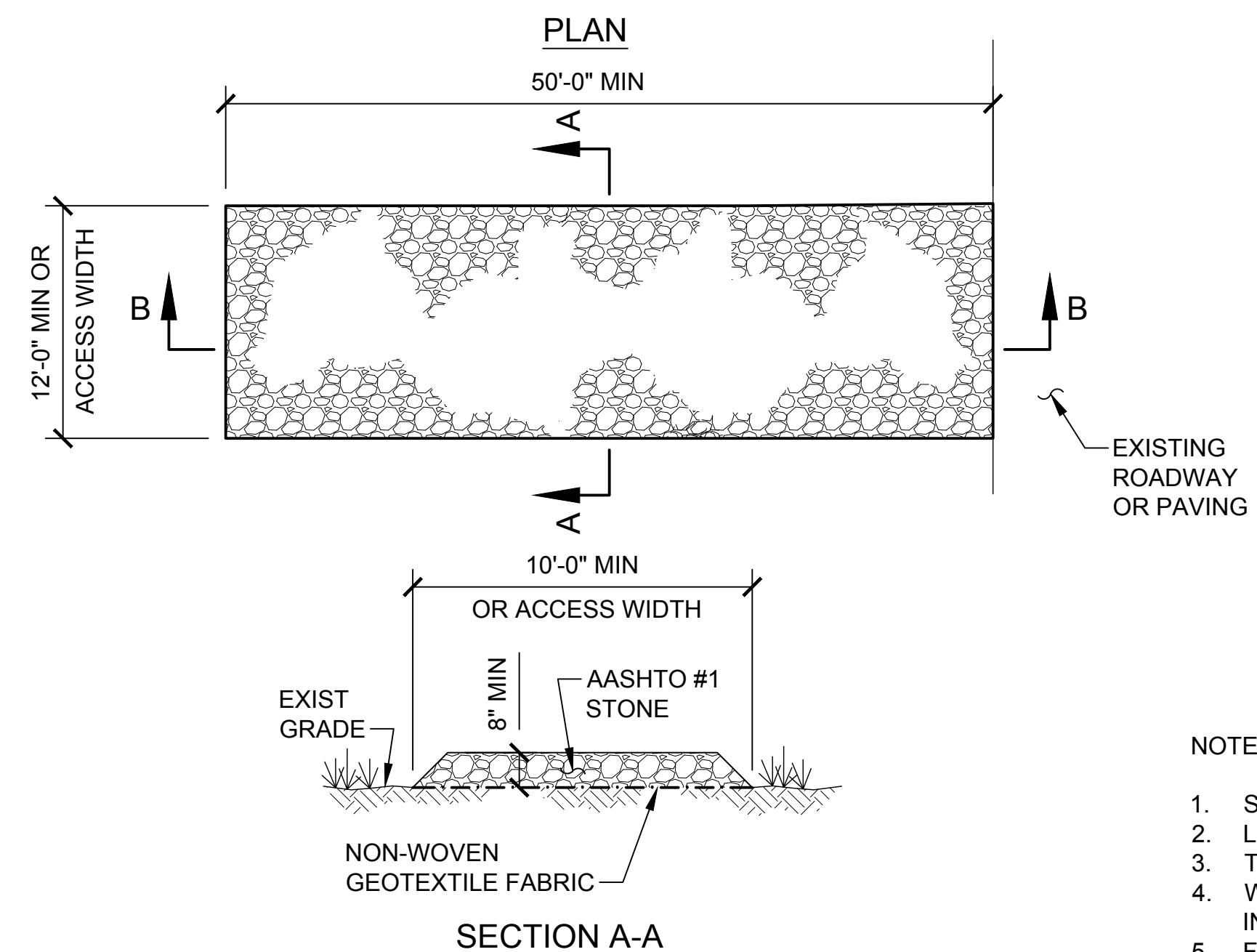

- NOTES**
- THE SEDIMENT LOG PLACEMENT AREA SHALL BE PREPARED SO THAT IT IS FREE OF ALL DEBRIS, INCLUDING ROCKS, STICKS, ROOTS, ETC. A 2 INCH LAYER OF COMPACTED FILL MATERIAL SHALL BE PLACED ON THE UPSLOPE SIDE OF THE LOG TO PREVENT UNDERCUTTING. WHERE MORE THAN ONE LOG IS REQUIRED TO OBTAIN SPECIFIED LENGTH, LOGS SHALL BE TIGHTLY ABUTTED AND SECURELY STAKED (OR OVERLAPPED BY 12 INCHES MINIMUM). A LAYER OF AASHTO #57 STONE SHALL BE PLACED WHERE ABUTTING LOGS COME TOGETHER (EXTENDING 2 FEET ON BOTH SIDES OF THE LOG).
 - SEDIMENT FILTER LOGS SHALL BE PLACED AT EXISTING LEVEL GRADE. ENDS SHALL BE EXTENDED UPSLOPE AT 45 DEGREES TO THE MAIN FILTER LOG ALIGNMENT FOR A MINIMUM OF 8 FEET.
 - SEDIMENT FILTER LOGS SHALL BE INSPECTED WEEKLY AND AFTER EACH RUNOFF EVENT.
 - SEDIMENT DEPOSITS SHALL BE CLEANED FROM THE LOG WHEN IT REACHES HALF THE HEIGHT OF THE LOG.
 - DAMAGED FILTER LOGS SHALL BE REPLACED WITHIN 24 HOURS OF INSPECTION. A SUPPLY OF FILTER LOGS SHALL BE MAINTAINED ON SITE FOR THIS PURPOSE.
 - THE CONTRACTOR MAY PROPOSE AN ALTERNATE METHOD TO SECURE SEDIMENT FILTER LOGS IN TURF AREAS WHERE STAKING MAY DAMAGE THE TURF.

3 SEDIMENT FILTER LOG NTS

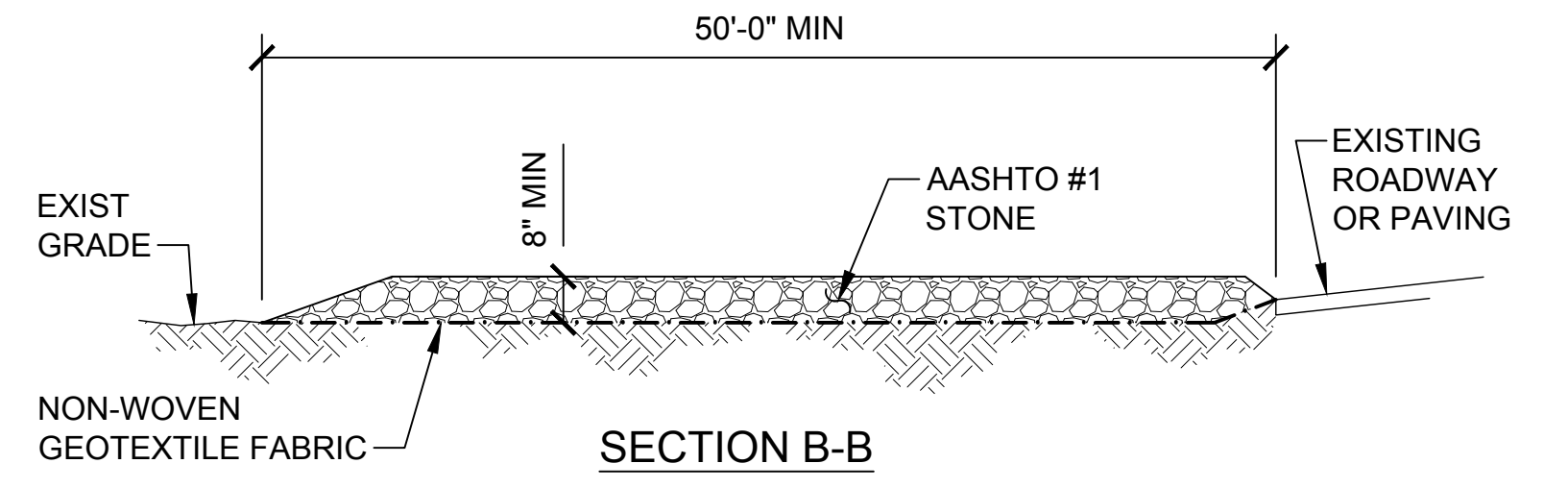

5 STABILIZED CONSTRUCTION ENTRANCE NTS

- NOTES:**
- STONE SIZE - USE 2-INCH STONE
 - LENGTH - AS REQUIRED, BUT NOT LESS THAN 50 FEET.
 - THICKNESS - NOT LESS THAN 12 INCHES.
 - WIDTH - 12 FT. MINIMUM, BUT NOT LESS THAN THE FULL WIDTH AT POINTS WHERE INGRESS OR EGRESS OCCUR.
 - FILTER FABRIC - PLACE OVER THE ENTIRE AREA PRIOR TO PLACEMENT OF STONE.
 - SURFACE WATER - ALL SURFACE WATER FLOWING OR DIVERTED TOWARD CONSTRUCTION ENTRANCES SHALL BE PIPED ACROSS THE ENTRANCE. IF PIPING IS IMPRACTICAL, A MOUNTABLE BERM WITH 5H:1V SLOPES WILL BE PERMITTED.
 - MAINTENANCE - THE ENTRANCE SHALL BE MAINTAINED IN A CONDITION WHICH WILL PREVENT TRACKING OR FLOWING OF SEDIMENT OUTSIDE OF THE DESIGNATED CONSTRUCTION AREA. THIS MAY REQUIRE PERIODIC TOP DRESSING WITH ADDITIONAL STONE AS CONDITIONS DEMAND AND REPAIR AND/OR CLEANOUT OF ANY MEASURES USED TO TRAP SEDIMENT. ALL SEDIMENT SPILLED, DROPPED, WASHED OR TRACKED OUTSIDE OF THE CONSTRUCTION LIMITS MUST BE REMOVED IMMEDIATELY.
 - WASHING - WHEELS SHALL BE CLEANED TO REMOVE SEDIMENT PRIOR TO ENTRANCE OUTSIDE THE CONSTRUCTION LIMITS. WHEN WASHING IS REQUIRED IT SHALL BE DONE ON AN AREA STABILIZED WITH STONE AND WHICH DRAINS INTO AN APPROVED SEDIMENT TRAPPING DEVICE.
 - PERIODIC INSPECTION AND NEEDED MAINTENANCE SHALL BE PROVIDED AFTER EACH RAINFALL OR RUNOFF EVENT.

MARK	DATE	DESCRIPTION	BY
C	11/01/19	ISSUED FOR BID - 95%	AW
B	10/18/19	75% DESIGN SUBMITTAL	AW
A	09/06/19	50% DESIGN SUBMITTAL	AW

ISSUE BLOCK

PROJECT NO.:	3019666
DESIGNED BY:	KM
DRAWN BY:	KM
CHECKED BY:	AW
APPROVED BY:	
COPYRIGHT:	STV, INC
SHEET TITLE	

SITE PLAN

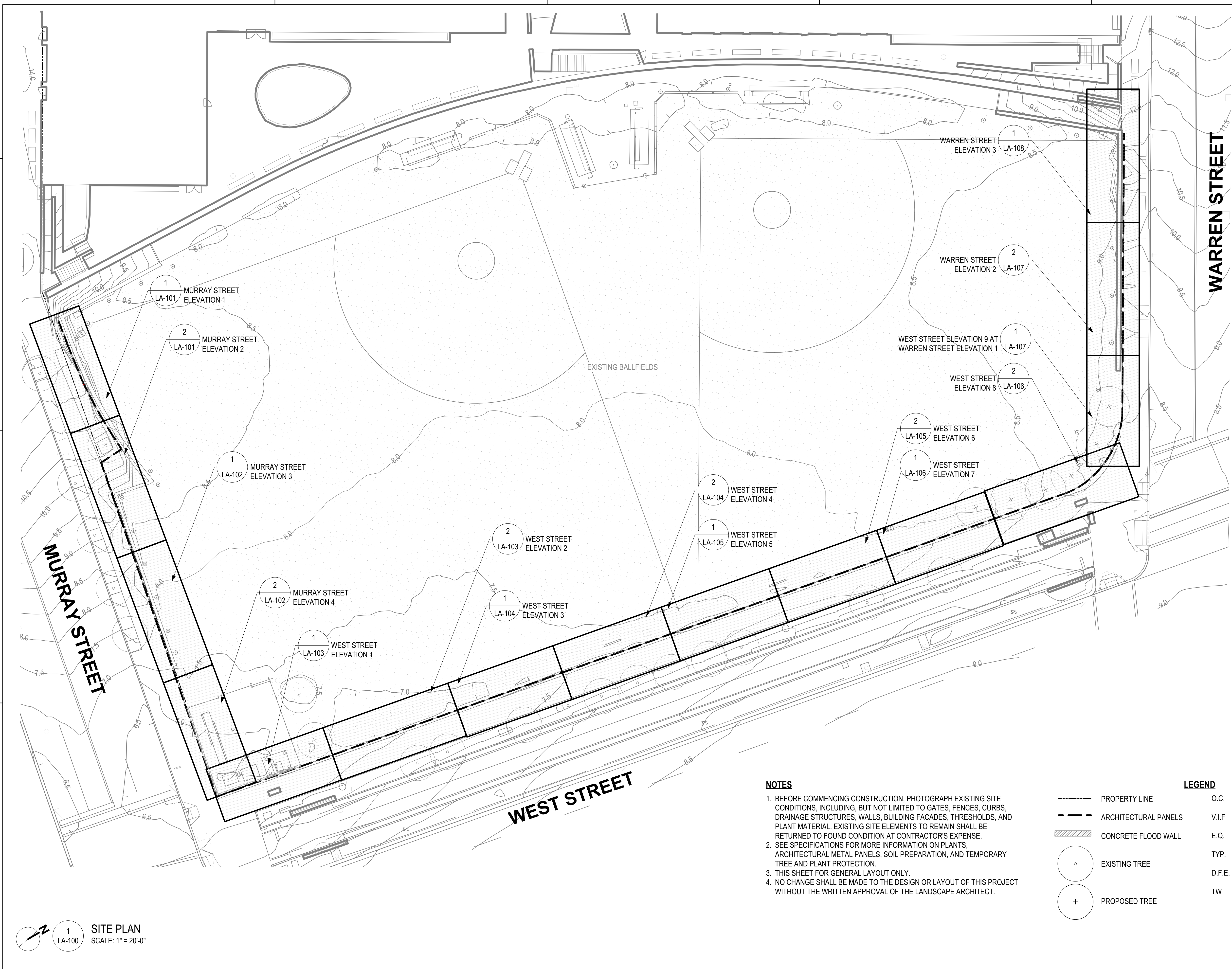

NOTES

- BEFORE COMMENCING CONSTRUCTION, PHOTOGRAPH EXISTING SITE CONDITIONS, INCLUDING, BUT NOT LIMITED TO GATES, FENCES, CURBS, DRAINAGE STRUCTURES, WALLS, BUILDING FACADES, THRESHOLDS, AND PLANT MATERIAL. EXISTING SITE ELEMENTS TO REMAIN SHALL BE RETURNED TO FOUND CONDITION AT CONTRACTOR'S EXPENSE.
- SEE SPECIFICATIONS FOR MORE INFORMATION ON PLANTS, ARCHITECTURAL METAL PANELS, SOIL PREPARATION, AND TEMPORARY TREE AND PLANT PROTECTION.
- THIS SHEET FOR GENERAL LAYOUT ONLY.
- NO CHANGE SHALL BE MADE TO THE DESIGN OR LAYOUT OF THIS PROJECT WITHOUT THE WRITTEN APPROVAL OF THE LANDSCAPE ARCHITECT.

LEGEND

- | | | | |
|--------|----------------------|--------|------------------------|
| ----- | PROPERTY LINE | O.C. | ON CENTER |
| --- -- | ARCHITECTURAL PANELS | V.I.F | VERIFY IN FIELD |
| ▨ | CONCRETE FLOOD WALL | E.Q. | EQUAL |
| ○ | EXISTING TREE | TYP. | TYPICAL |
| + | PROPOSED TREE | D.F.E. | DESIGN FLOOD ELEVATION |
| | | TW | TOP OF WALL |

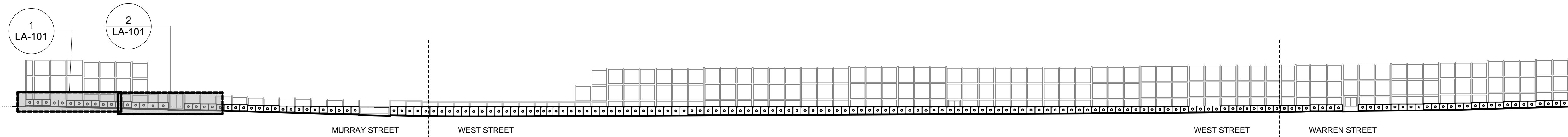

ELEVATION KEY PLAN
SCALE: 1" = 30'-0"

NOTES:
1. ALL DIMENSIONS TO BE VIF
2. SEE ENLARGEMENTS LA-503

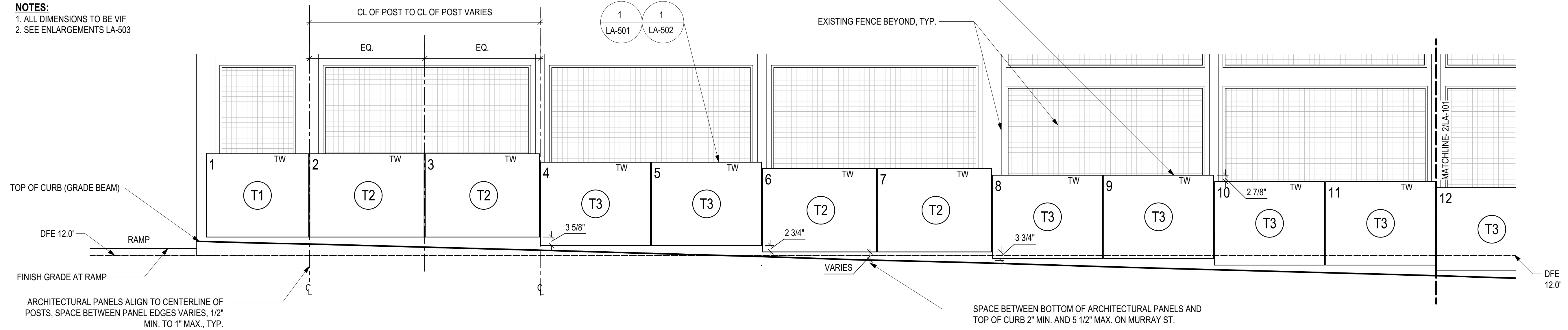

1 MURRAY STREET ELEVATION 1
LA-101 SCALE: 1/2" = 1'-0"

NOTE:
'LA' SERIES DRAWINGS FOR ARCHITECTURAL PANELS ONLY. SEE 'S' SERIES FOR ALL STEEL FLOODWALL INFORMATION AND DETAILS.

NOTES:
1. ALL DIMENSIONS TO BE VIF
2. SEE ENLARGEMENTS LA-503

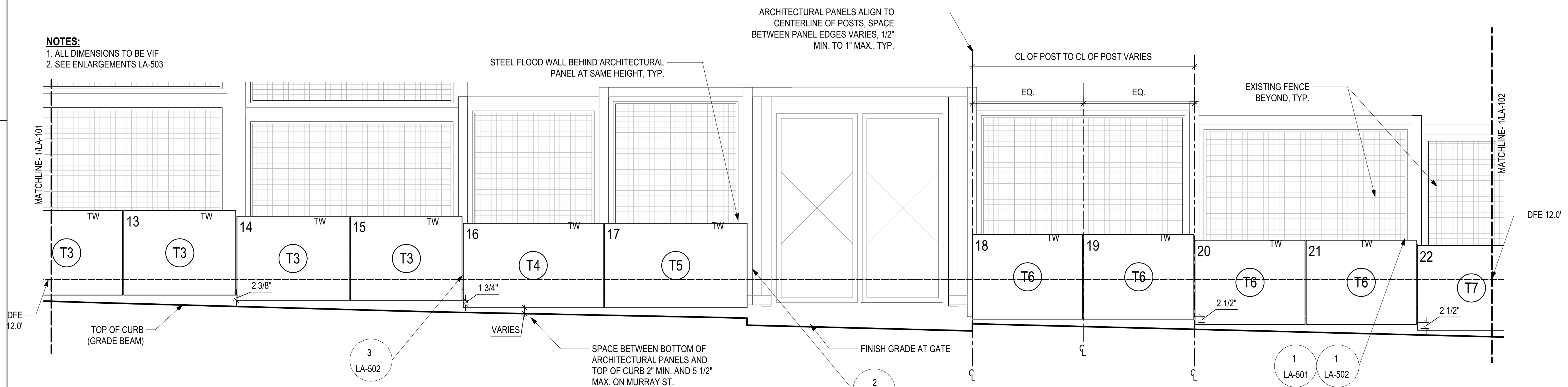

2 MURRAY STREET ELEVATION 2
LA-101 SCALE: 1/2" = 1'-0"

SEALS

PROJECT IDENTIFICATION



BATTERY PARK CITY
BALLFIELD AND COMMUNITY
CENTER

MARK	DATE	DESCRIPTION	BY
C	11/01/19	ISSUED FOR BID - 95%	AW
B	10/18/19	75% DESIGN SUBMITTAL	AW
A	09/06/19	50% DESIGN SUBMITTAL	AW

ISSUE BLOCK

PROJECT NO.:	3019666
DESIGNED BY:	KM
DRAWN BY:	KM
CHECKED BY:	AW
APPROVED BY:	
COPYRIGHT:	STV, INC

SHEET TITLE

FENCE
PANEL
ELEVATION

LA-101

MARK	DATE	DESCRIPTION	BY
C	11/01/19	ISSUED FOR BID - 95%	AW
B	10/18/19	75% DESIGN SUBMITTAL	AW
A	09/06/19	50% DESIGN SUBMITTAL	AW

ISSUE BLOCK

PROJECT NO.:	3019666
DESIGNED BY:	KM
DRAWN BY:	KM
CHECKED BY:	AW
APPROVED BY:	
COPYRIGHT:	STV, INC

SHEET TITLE

FENCE
PANEL
ELEVATION

LA-102

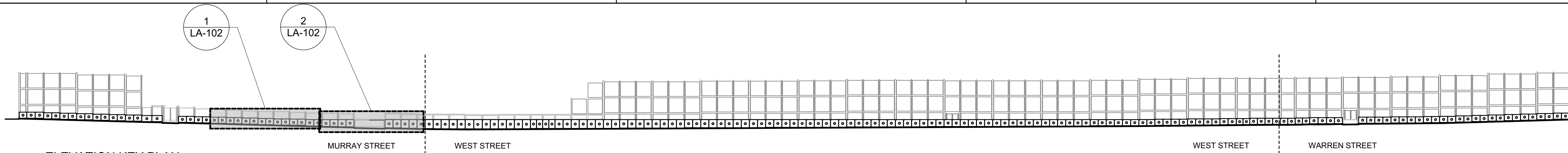

- NOTES:**
1. ALL DIMENSIONS TO BE VIF
2. SEE ENLARGEMENTS LA-503

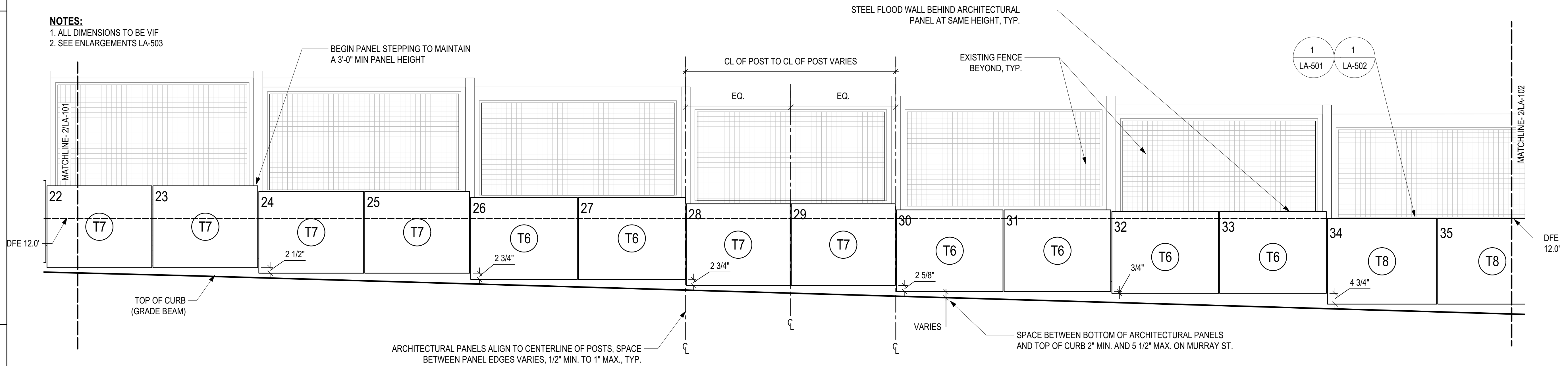

- NOTES:**
1. ALL DIMENSIONS TO BE VIF
2. SEE ENLARGEMENTS LA-503

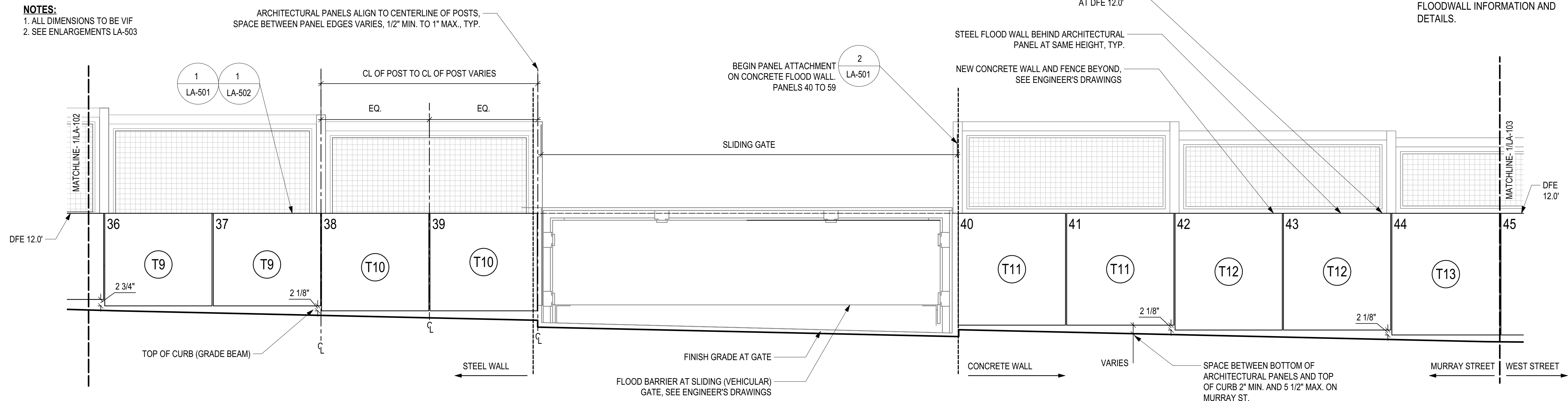

NOTE:
'LA' SERIES DRAWINGS FOR ARCHITECTURAL PANELS ONLY. SEE 'S' SERIES FOR ALL STEEL FLOODWALL INFORMATION AND DETAILS.

MARK	DATE	DESCRIPTION	BY
C	11/01/19	ISSUED FOR BID - 95%	AW
B	10/18/19	75% DESIGN SUBMITTAL	AW
A	09/06/19	50% DESIGN SUBMITTAL	AW

ISSUE BLOCK

PROJECT NO.:	3019666
DESIGNED BY:	KM
DRAWN BY:	KM
CHECKED BY:	AW
APPROVED BY:	
COPYRIGHT:	STV, INC
SHEET TITLE	

FENCE
PANEL
ELEVATION

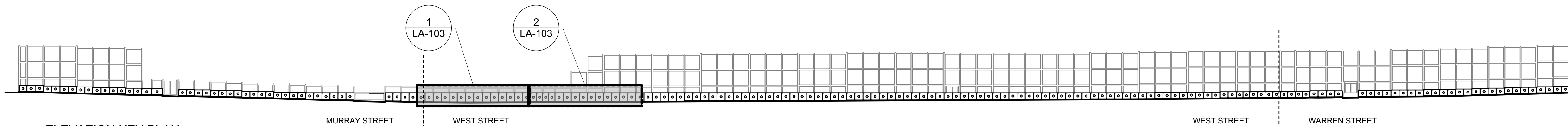

- NOTES:**
1. ALL DIMENSIONS TO BE VIF
2. SEE ENLARGEMENTS LA-503

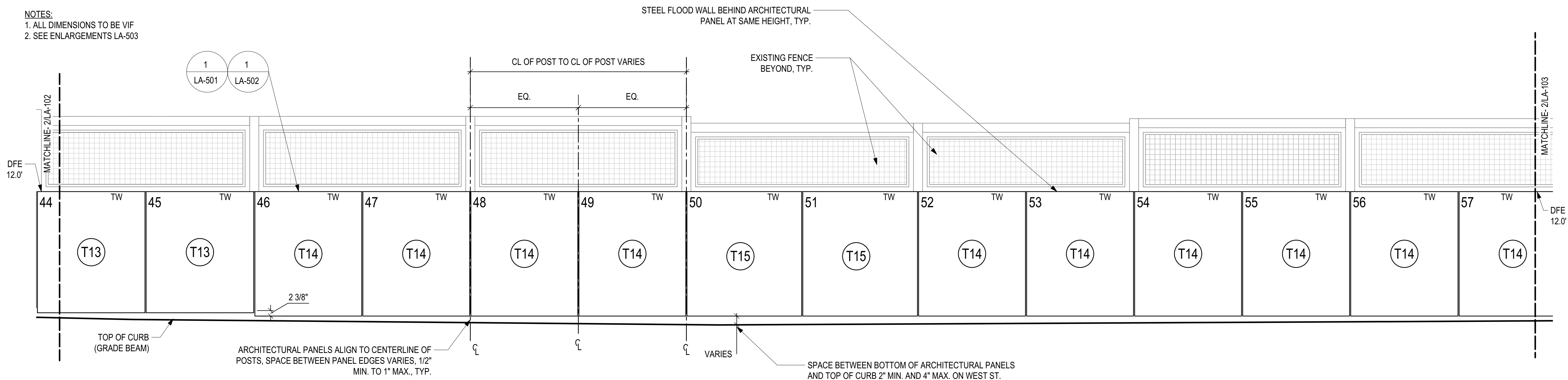

NOTE:
'LA' SERIES DRAWINGS FOR ARCHITECTURAL PANELS ONLY. SEE 'S' SERIES FOR ALL STEEL FLOODWALL INFORMATION AND DETAILS.

- NOTES:**
1. ALL DIMENSIONS TO BE VIF
2. SEE ENLARGEMENTS LA-503

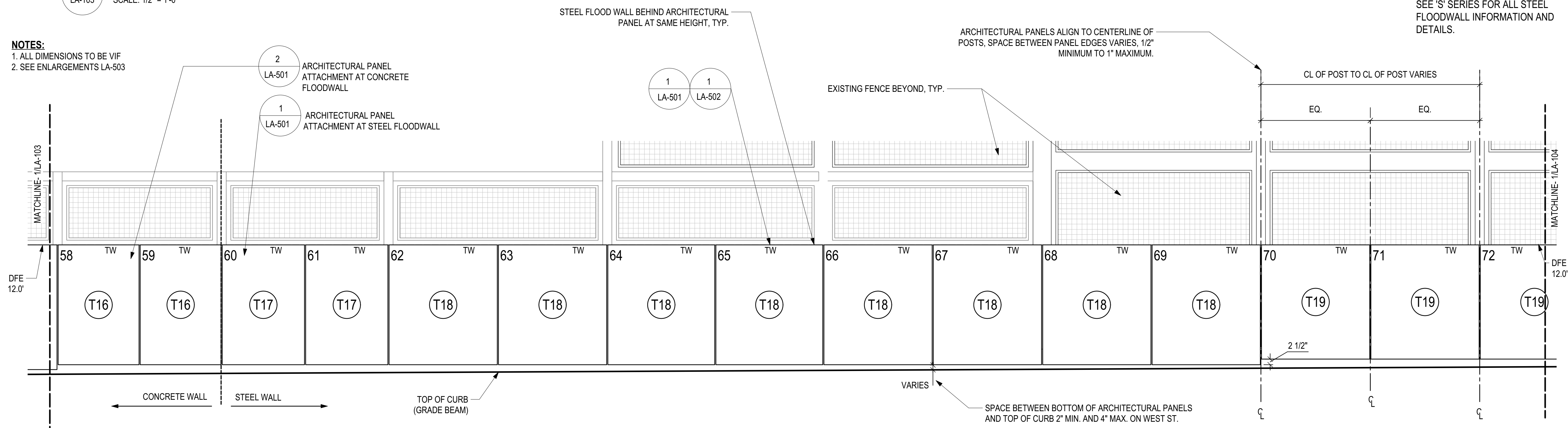

FENCE
PANEL
ELEVATION

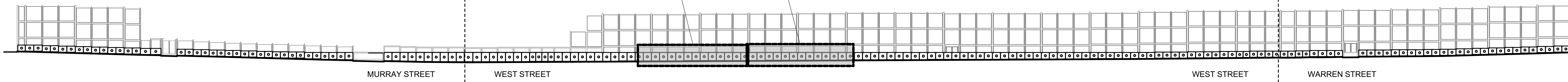

ELEVATION KEY PLAN
SCALE: 1" = 30'-0"

NOTES:
1. ALL DIMENSIONS TO BE VIF
2. SEE ENLARGEMENTS LA-503

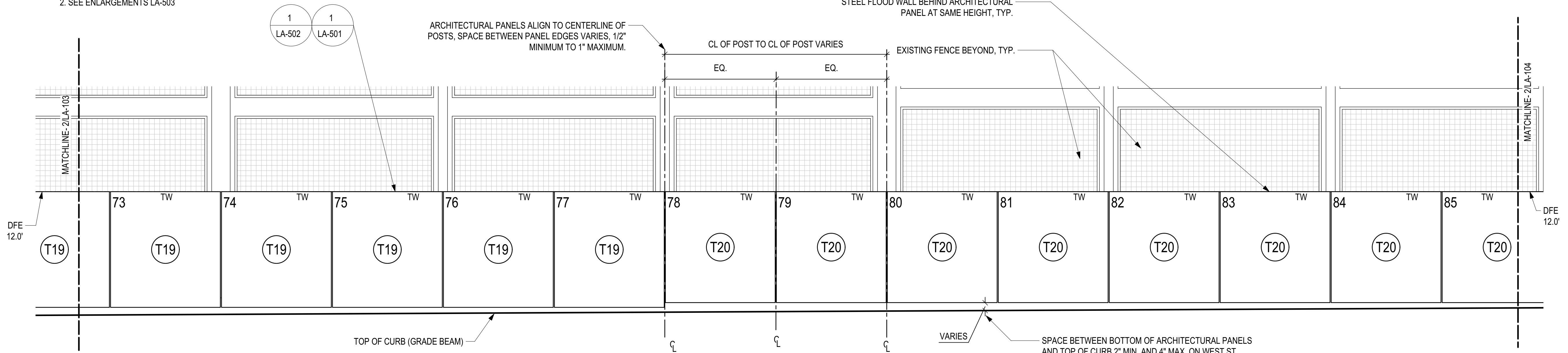

1 WEST STREET ELEVATION 3
LA-104 SCALE: 1/2" = 1'-0"

NOTE:
'LA' SERIES DRAWINGS FOR ARCHITECTURAL PANELS ONLY. SEE 'S' SERIES FOR ALL STEEL FLOODWALL INFORMATION AND DETAILS.

NOTES:
1. ALL DIMENSIONS TO BE VIF
2. SEE ENLARGEMENTS LA-503

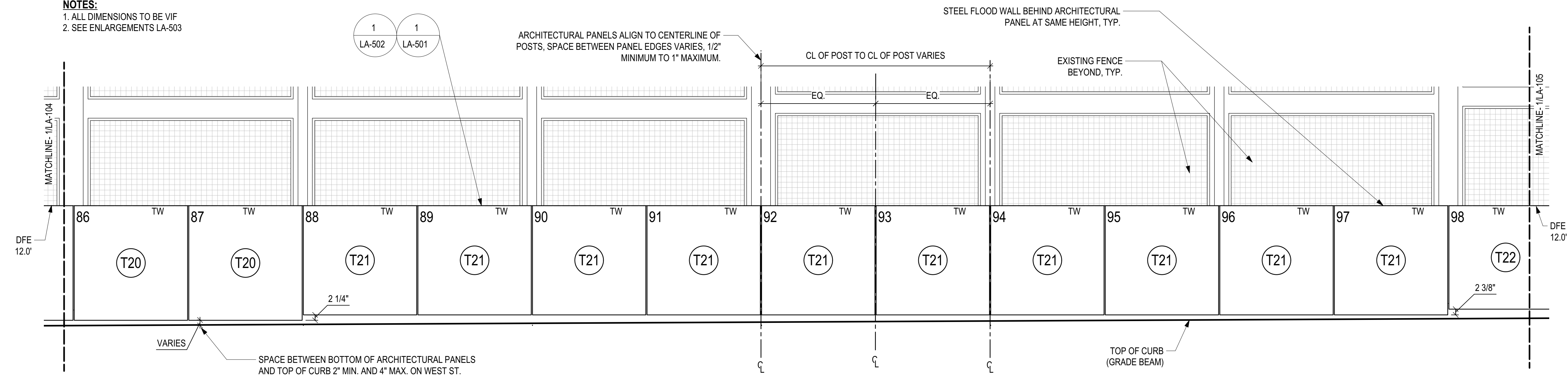

2 WEST STREET ELEVATION 4
LA-104 SCALE: 1/2" = 1'-0"

SEALS

PROJECT IDENTIFICATION



BATTERY PARK CITY
BALLFIELD AND COMMUNITY
CENTER

MARK	DATE	DESCRIPTION	BY
C	11/01/19	ISSUED FOR BID - 95%	AW
B	10/18/19	75% DESIGN SUBMITTAL	AW
A	09/06/19	50% DESIGN SUBMITTAL	AW

ISSUE BLOCK

PROJECT NO.:	3019666
DESIGNED BY:	KM
DRAWN BY:	KM
CHECKED BY:	AW
APPROVED BY:	
COPYRIGHT:	STV, INC

SHEET TITLE

FENCE
PANEL
ELEVATION

LA-104

MARK	DATE	DESCRIPTION	BY
C	11/01/19	ISSUED FOR BID - 95%	AW
B	10/18/19	75% DESIGN SUBMITTAL	AW
A	09/06/19	50% DESIGN SUBMITTAL	AW

ISSUE BLOCK

PROJECT NO.:	3019666
DESIGNED BY:	KM
DRAWN BY:	KM
CHECKED BY:	AW
APPROVED BY:	
COPYRIGHT:	STV, INC

SHEET TITLE

FENCE
PANEL
ELEVATION

LA-105

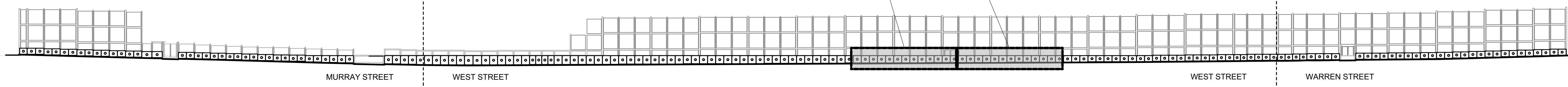

ELEVATION KEY PLAN
SCALE: 1" = 30'-0"

NOTES:
1. ALL DIMENSIONS TO BE VIF
2. SEE ENLARGEMENTS LA-503

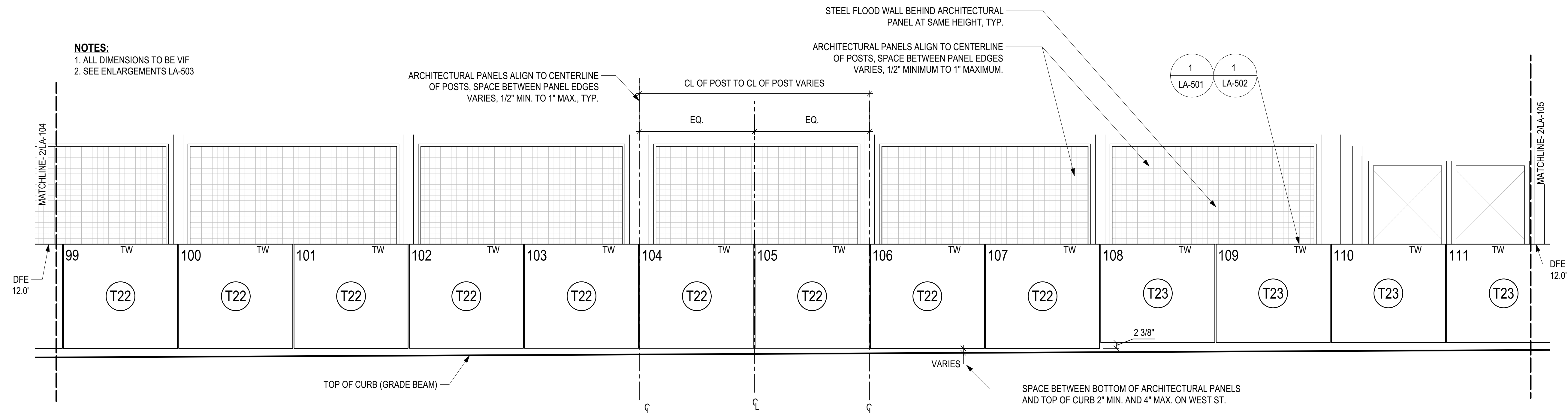

1 WEST STREET ELEVATION 5
LA-105 SCALE: 1/2" = 1'-0"

NOTE:
'LA' SERIES DRAWINGS FOR ARCHITECTURAL PANELS ONLY. SEE 'S' SERIES FOR ALL STEEL FLOODWALL INFORMATION AND DETAILS.

NOTES:
1. ALL DIMENSIONS TO BE VIF
2. SEE ENLARGEMENTS LA-503

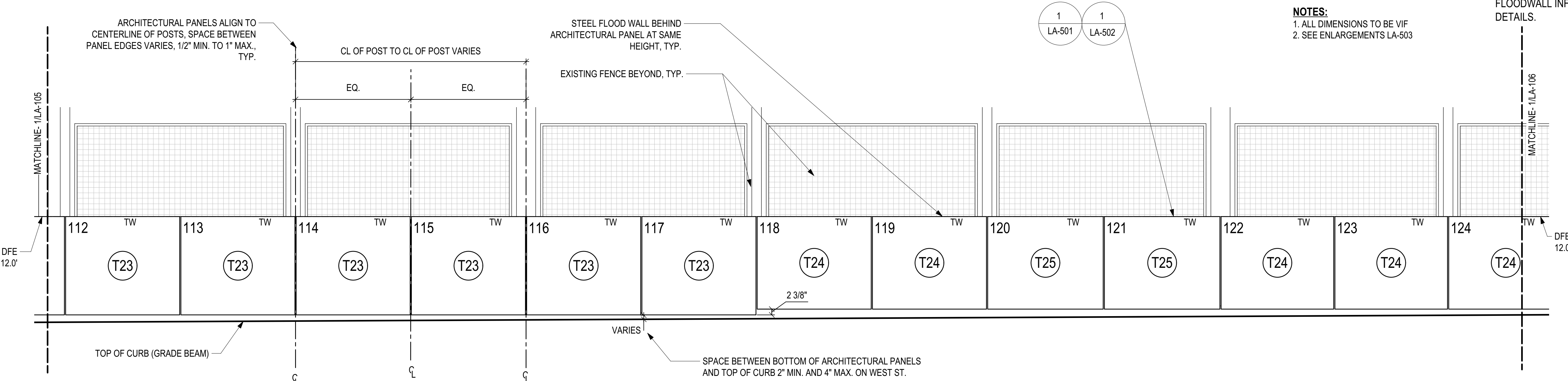

2 WEST STREET ELEVATION 6
LA-105 SCALE: 1/2" = 1'-0"

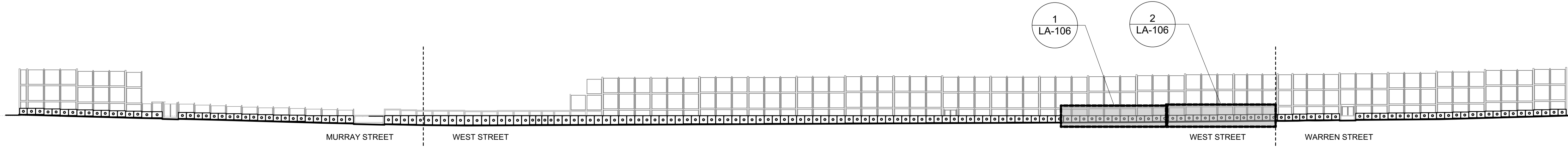

ELEVATION KEY PLAN
SCALE: 1" = 30'-0"

NOTES:
1. ALL DIMENSIONS TO BE VIF
2. SEE ENLARGEMENTS LA-503

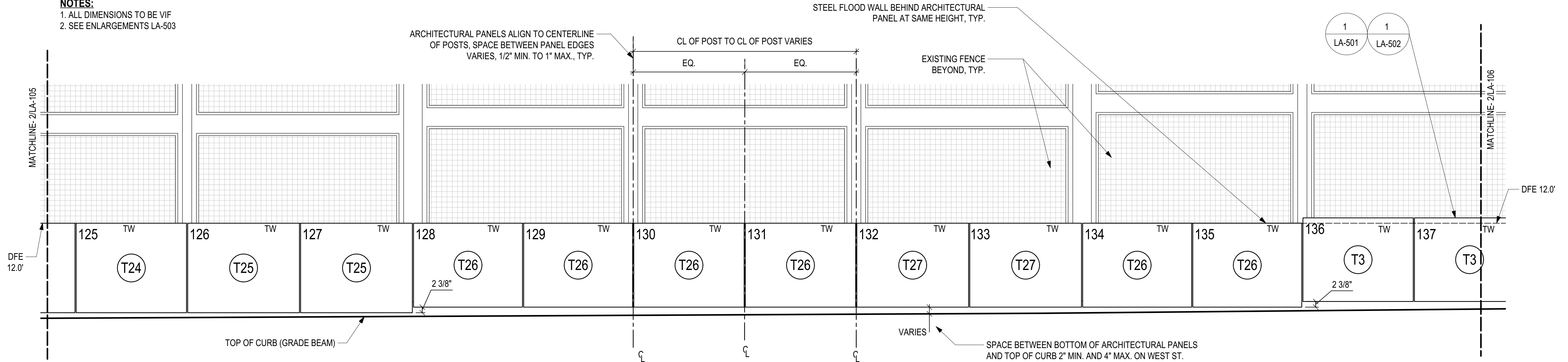

1 WEST STREET ELEVATION 7
SCALE: 1/2" = 1'-0"

NOTE:
'LA' SERIES DRAWINGS FOR ARCHITECTURAL PANELS ONLY. SEE 'S' SERIES FOR ALL STEEL FLOODWALL INFORMATION AND DETAILS.

NOTES:
1. ALL DIMENSIONS TO BE VIF
2. SEE ENLARGEMENTS LA-503

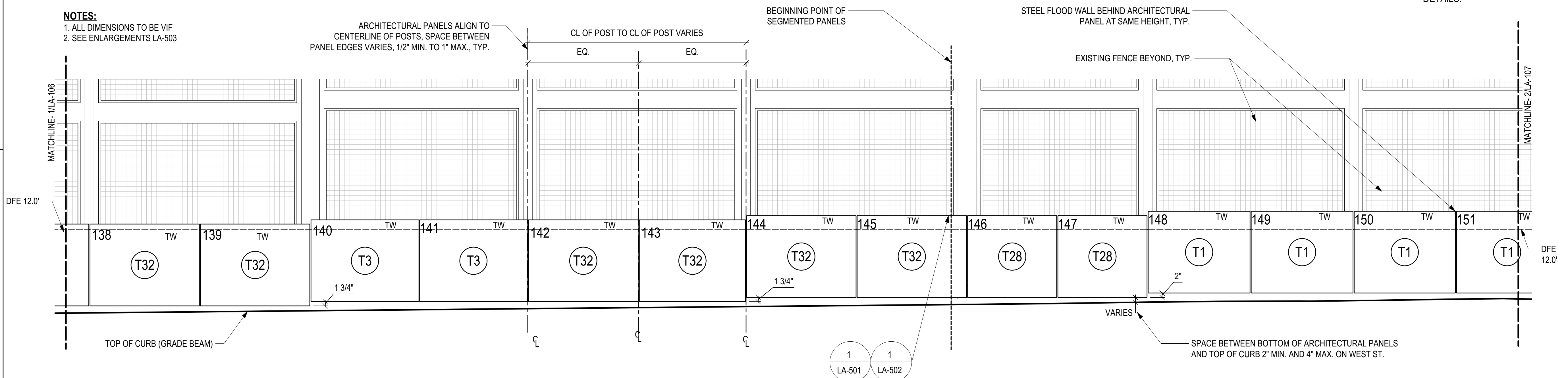

2 WEST STREET ELEVATION 8
SCALE: 1/2" = 1'-0"

SEALS

PROJECT IDENTIFICATION

NEW YORK STATE OF OPPORTUNITY
Battery Park City Authority
BATTERY PARK CITY
BALLFIELD AND COMMUNITY
CENTER

MARK	DATE	DESCRIPTION	BY
C	11/01/19	ISSUED FOR BID - 95%	AW
B	10/18/19	75% DESIGN SUBMITTAL	AW
A	09/06/19	50% DESIGN SUBMITTAL	AW

ISSUE BLOCK

PROJECT NO.:	3019666
DESIGNED BY:	KM
DRAWN BY:	KM
CHECKED BY:	AW
APPROVED BY:	
COPYRIGHT:	STV, INC

SHEET TITLE

FENCE
PANEL
ELEVATION

LA-106

MARK	DATE	DESCRIPTION	BY
C	11/01/19	ISSUED FOR BID - 95%	AW
B	10/18/19	75% DESIGN SUBMITTAL	AW
A	09/06/19	50% DESIGN SUBMITTAL	AW

ISSUE BLOCK

PROJECT NO.:	3019666
DESIGNED BY:	KM
DRAWN BY:	KM
CHECKED BY:	AW
APPROVED BY:	
COPYRIGHT:	STV, INC

SHEET TITLE

FENCE
PANEL
ELEVATION

LA-107

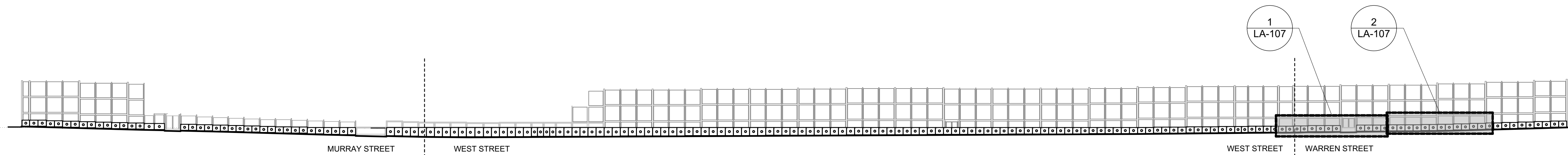

ELEVATION KEY PLAN
SCALE: 1" = 30'-0"

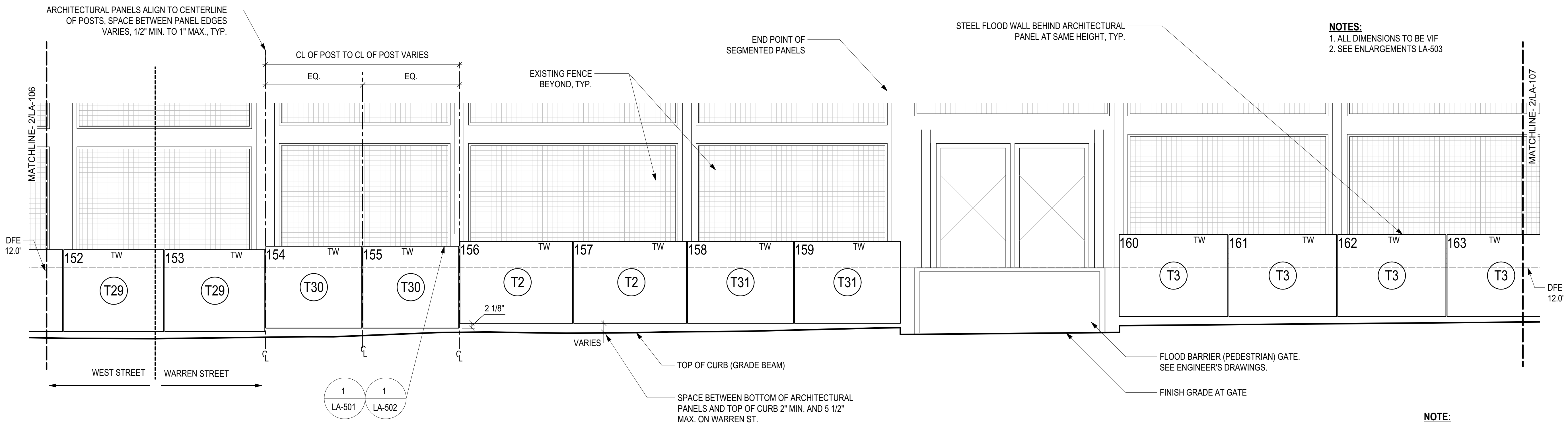

1 WEST STREET 9 AT WARREN STREET ELEVATION 1
SCALE: 1/2" = 1'-0"

- NOTES:
1. ALL DIMENSIONS TO BE VIF
2. SEE ENLARGEMENTS LA-503

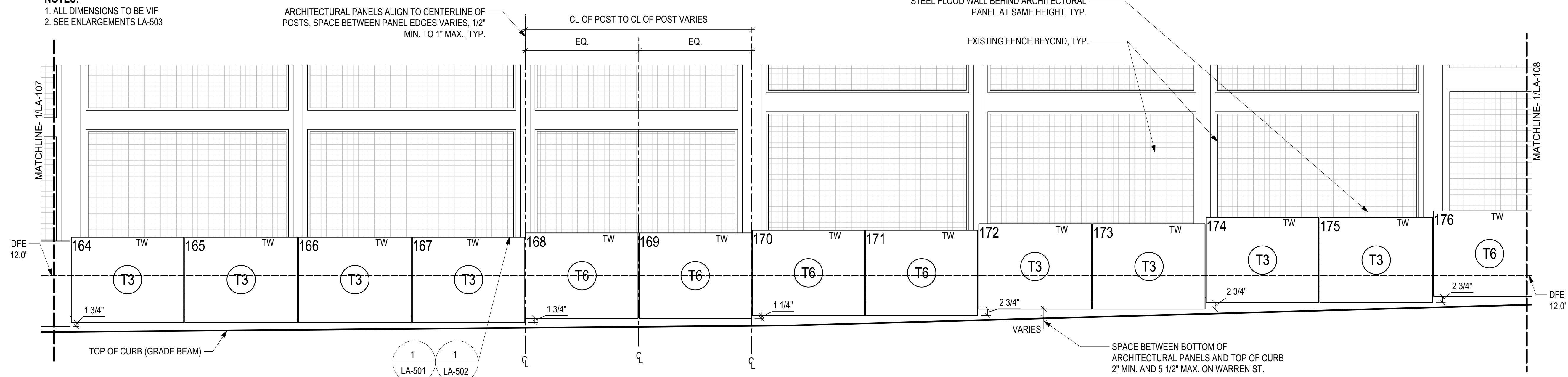

2 WARREN STREET ELEVATION 2
SCALE: 1/2" = 1'-0"

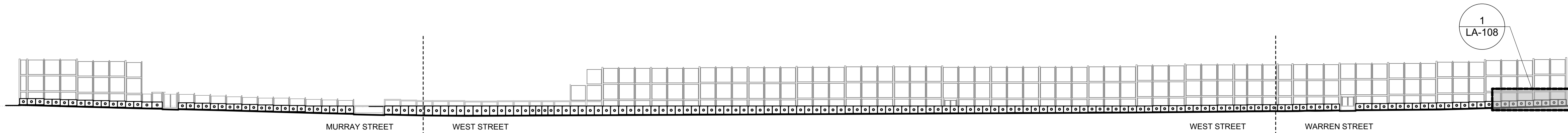

ELEVATION KEY PLAN
SCALE: 1" = 30'-0"

- NOTES:**
1. ALL DIMENSIONS TO BE VIF
2. SEE ENLARGEMENTS LA-503

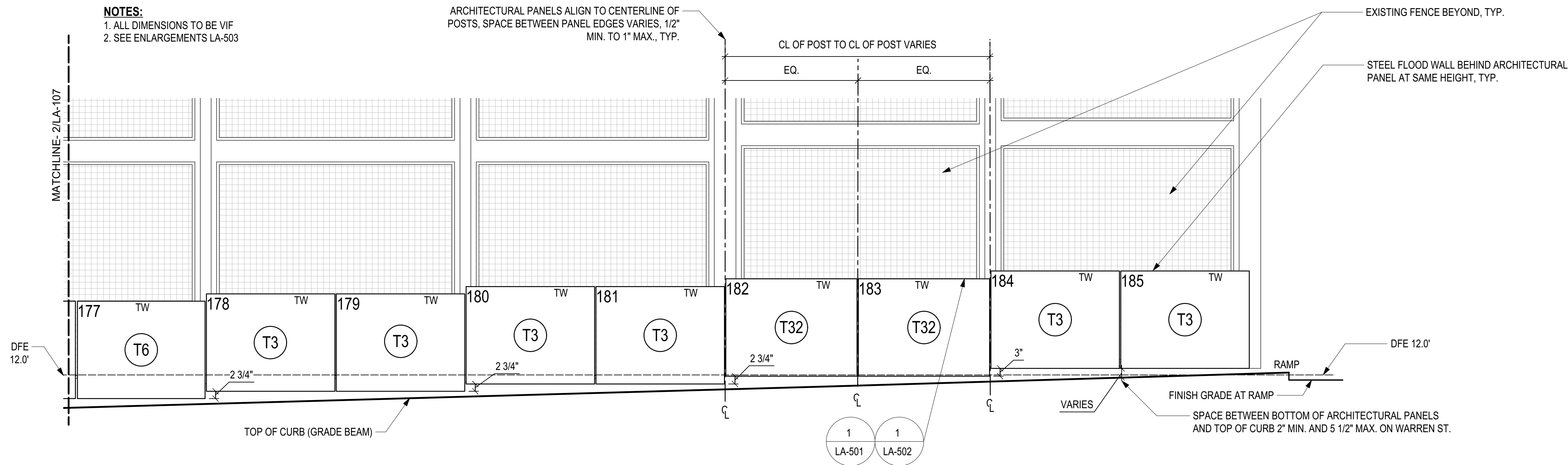

1 LA-108 WARREN STREET ELEVATION 3
SCALE: 1/2" = 1'-0"

- NOTES:**
1. ALL DIMENSIONS IN ARCHITECTURAL PANEL SCHEDULE TO BE VIF.

ARCHITECTURAL PANEL SCHEDULE

PANEL TYPE	QUANTITY	WIDTH	HEIGHT	THICKNESS
T1	5	3'8 1/4"	3'0"	1/4"
T2	6	4'1 1/4"	3'0"	1/4"
T3	32	3'11 3/8"	3'0"	1/4"
T4	1	4'11 3/4"	3'0"	1/4"
T5	1	5'0 7/8"	3'0"	1/4"
T6	16	3'10 3/4"	3'0"	1/4"
T7	6	3'9 5/8"	3'0"	1/4"
T8	2	4'0"	3'1 3/4"	1/4"
T9	2	3'10 7/8"	3'4 1/2"	1/4"
T10	2	3'10 7/8"	3'6 5/8"	1/4"
T11	2	3'10 7/8"	4'0 7/8"	1/4"
T12	2	3'10 7/8"	4'3"	1/4"
T13	2	3'11 1/4"	4'5 1/4"	1/4"
T14	10	3'10 7/8"	4'6 5/8"	1/4"
T15	2	4'2 3/8"	4'6 5/8"	1/4"
T16	2	2'11 1/2"	4'4 1/2"	1/4"

PANEL TYPE	QUANTITY	WIDTH	HEIGHT	THICKNESS
T17	2	3'0 1/8"	4'4 1/2"	1/4"
T18	8	3'10 7/8"	4'4 1/2"	1/4"
T19	8	3'11 1/2"	4'2"	1/4"
T20	10	3'11 1/2"	4'0"	1/4"
T21	10	3'11 1/2"	3'9 3/4"	1/4"
T22	10	3'11 1/2"	3'7 3/8"	1/4"
T23	10	3'11 1/2"	3'5"	1/4"
T24	6	3'10 7/8"	3'2 1/2"	1/4"
T25	4	4'0 1/8"	3'2 1/2"	1/4"
T26	6	3'10 7/8"	3'0 1/8"	1/4"
T27	2	4'0 1/8"	3'0 1/8"	1/4"
T28	2	3'3 1/4"	3'0"	1/4"
T29	2	3'7 7/8"	3'0"	1/4"
T30	2	3'6 1/8"	3'0"	1/4"
T31	2	3'10 1/2"	3'0"	1/4"
T32	8	4'0"	3'0"	1/4"
TOTAL	185			

NOTE:
'LA' SERIES DRAWINGS FOR ARCHITECTURAL PANELS ONLY. SEE 'S' SERIES FOR ALL STEEL FLOODWALL INFORMATION AND DETAILS.

SEALS

PROJECT IDENTIFICATION

NEW YORK STATE OF OPPORTUNITY
Battery Park City Authority

BATTERY PARK CITY BALLFIELD AND COMMUNITY CENTER

MARK	DATE	DESCRIPTION	BY
C	11/01/19	ISSUED FOR BID - 95%	AW
B	10/18/19	75% DESIGN SUBMITTAL	AW
A	09/06/19	50% DESIGN SUBMITTAL	AW

ISSUE BLOCK

PROJECT NO.:	3019666
DESIGNED BY:	KM
DRAWN BY:	KM
CHECKED BY:	AW
APPROVED BY:	
COPYRIGHT:	STV, INC

SHEET TITLE

FENCE PANEL ELEVATION

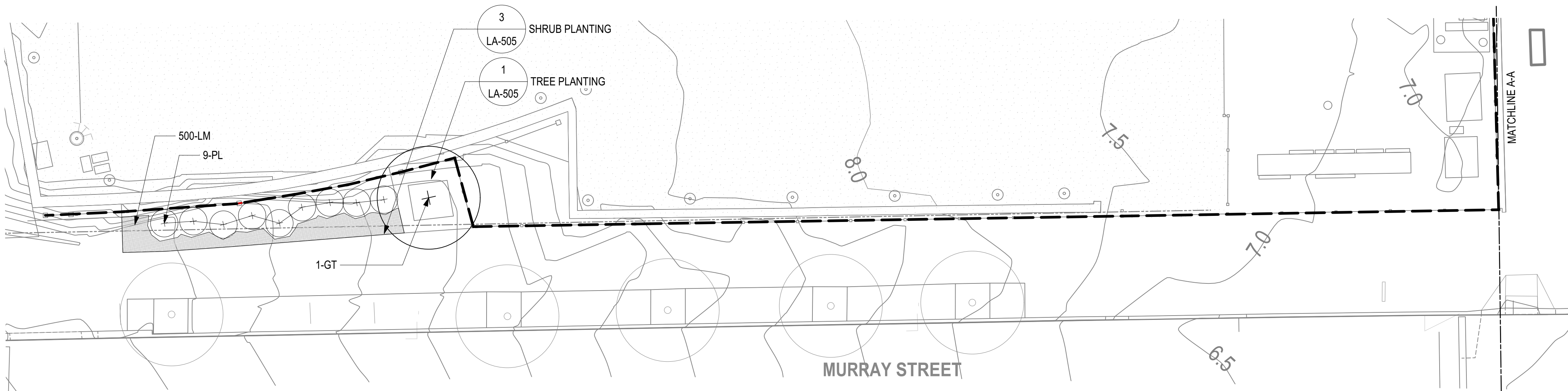

1 PLANTING PLAN - MURRAY STREET
LA-109 SCALE: 1" = 10'-0"



- LEGEND**
- PROPERTY LINE
 - - - ARCHITECTURAL PANELS
 - ▨ CONCRETE WALL
 - EXISTING TREE
 - ⊕ PROPOSED TREE
 - ⊙ PROPOSED SHRUB
 - ▨ PROPOSED GROUNDCOVER
 - ▨ EXISTING PLANTING AREA
 - ▨ EXISTING TURF FIELD
 - OC. ON CENTER
 - VIF. VERIFY IN FIELD
 - EQ. EQUAL
 - TYP. TYPICAL

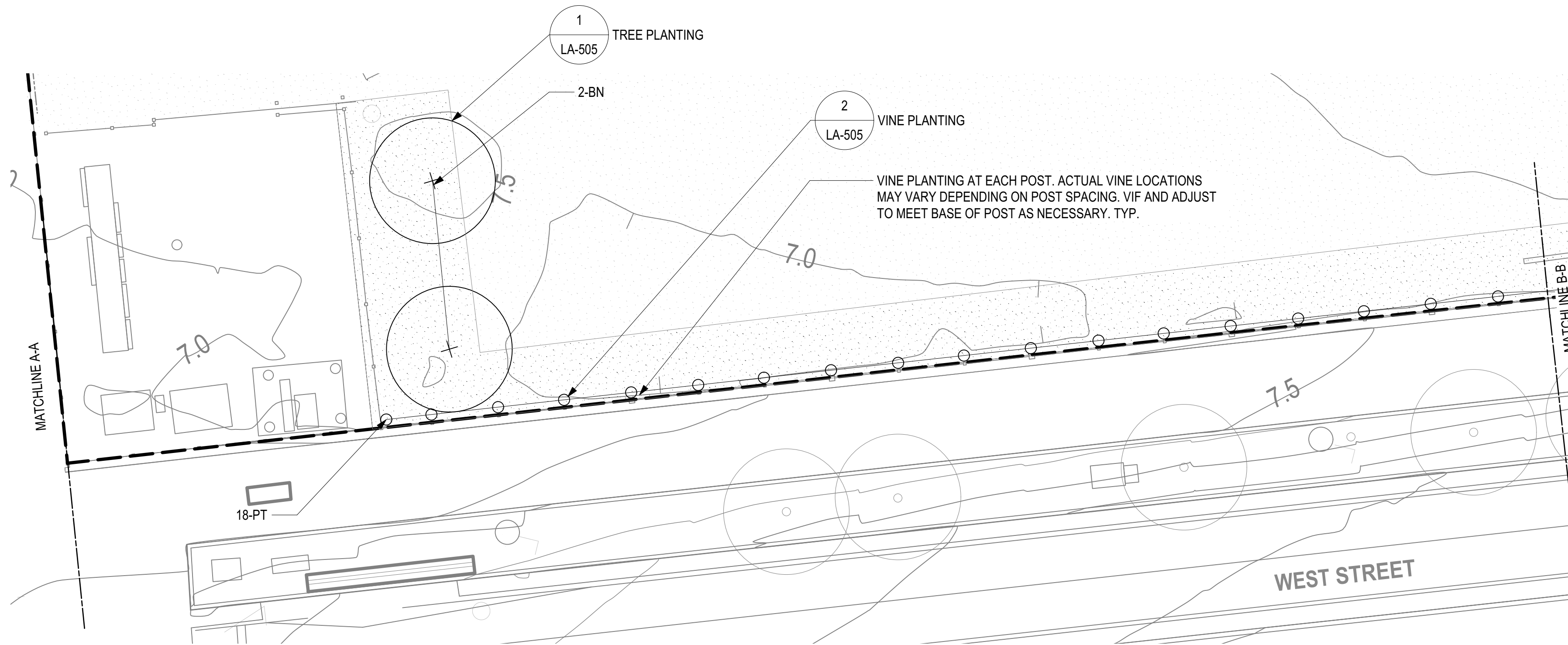

2 PLANTING PLAN - WEST STREET
LA-109 SCALE: 1" = 10'-0"



PLANTING NOTES

1. DISCREPANCIES BETWEEN ACTUAL FIELD CONDITIONS AND THOSE SHOWN ON THE PLANS ARE TO BE BROUGHT TO THE IMMEDIATE ATTENTION OF THE LANDSCAPE ARCHITECT. WORK SHALL NOT PROCEED UNTIL THE DISCREPANCY IS RESOLVED AND WRITTEN APPROVAL FROM THE LANDSCAPE ARCHITECT IS OBTAINED.
2. NOTIFY THE LANDSCAPE ARCHITECT, IN WRITING, OF DRAINAGE CONDITIONS DETRIMENTAL TO THE GROWTH OF PLANTS, PRIOR TO PLANTING.
3. PLANTS SHALL BE FRESHLY DUG; NEITHER HEELED-IN PLANTS NOR PLANTS FROM COLD STORAGE WILL BE ACCEPTED.
4. PLANTS SHALL BE SUBJECT TO INSPECTION AND APPROVAL BY THE LANDSCAPE ARCHITECT. THE LANDSCAPE ARCHITECT RESERVES THE RIGHT TO REJECT UNACCEPTABLE PLANT MATERIAL ON OR AFTER DELIVERY TO THE SITE.
5. TOPSOIL SHALL BE FREE OF SOIL-BORNE DISEASE AND PESTS, AS WELL AS WEED SEEDS.
6. PLANTING SHALL BE MULCHED AS PER SPEC IMMEDIATELY AFTER PLANTING. MULCH SHALL BE FREE OF INJURIOUS SUBSTANCE AND DEBRIS. MULCH SHALL BE SPREAD TO THE DEPTHS INDICATED ON THE DRAWINGS.
7. PLANTS SHALL BE IN ACCORDANCE WITH ANSI Z60.1 (LATEST ADDITION) FOR THE SIZES AND SPECIES INDICATED.
8. BEFORE COMMENCING CONSTRUCTION, CONTRACTOR SHALL FIELD VERIFY DIMENSIONS AND CONDITIONS OF THE SITE.
9. LANDSCAPE ARCHITECT SHALL APPROVE FINAL LAYOUT PRIOR TO PLANTING. PROVIDE 72 HOURS NOTICE OF ARRIVAL OF PLANT MATERIAL TO SITE.

ID	Qty	Latin Name	Common Name	Scheduled Size	Remarks
BN	2	Betula nigra 'Heritage'	Heritage River Birch	4"-4.5" Cal.	Multi-stem/clump (3)
GT	1	Gleditisa tricanthos 'Shademaster'	Honey Locust	4"-4.5" Cal.	
PT	18	Parthenocissus tricuspidata	Boston Ivy	1 gal.	
PL	9	Prunus laurocerasus 'Otto Luyken'	Cherry Laurel	3 gal.	
LM	500	Liriope muscari 'Variegata'	Variegated Lilly Turf	plugs	Spaced 6" O.C.

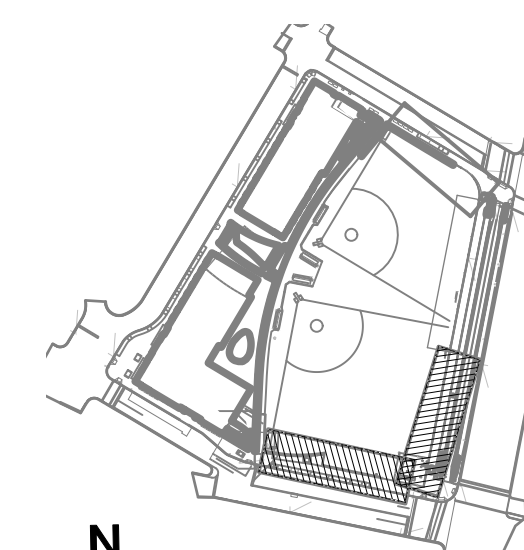

KEY PLAN
NOT TO SCALE

CONSULTANTS

SEALS

PROJECT IDENTIFICATION



BATTERY PARK CITY
BALLFIELD AND COMMUNITY
CENTER

MARK	DATE	DESCRIPTION	BY
C	11/01/19	ISSUED FOR BID - 95%	AW
B	10/18/19	75% DESIGN SUBMITTAL	AW
A	09/06/19	50% DESIGN SUBMITTAL	AW

ISSUE BLOCK

PROJECT NO.:	3019666
DESIGNED BY:	KM
DRAWN BY:	KM
CHECKED BY:	AW
APPROVED BY:	
COPYRIGHT:	STV, INC

SHEET TITLE

PLANTING
PLAN

LA-109

- LEGEND**
- PROPERTY LINE
 - - - ARCHITECTURAL PANELS
 - ▨ CONCRETE WALL
 - EXISTING TREE
 - ⊕ PROPOSED TREE
 - ⊙ PROPOSED SHRUB
 - ▭ PROPOSED GROUNDCOVER
 - ▨ EXISTING PLANTING AREA
 - ▨ EXISTING TURF FIELD
 - OC. ON CENTER
 - VIF. VERIFY IN FIELD
 - EQ. EQUAL
 - TYP. TYPICAL

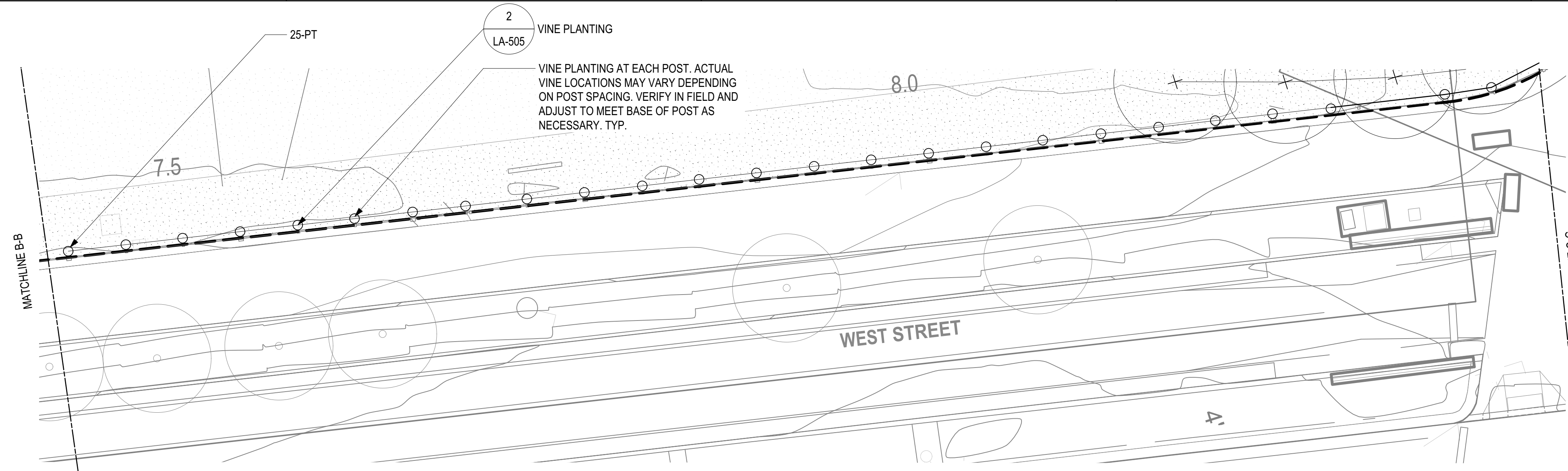

2
LA-505 VINE PLANTING
VINE PLANTING AT EACH POST. ACTUAL VINE LOCATIONS MAY VARY DEPENDING ON POST SPACING. VERIFY IN FIELD AND ADJUST TO MEET BASE OF POST AS NECESSARY. TYP.

1
LA-110 PLANTING PLAN - WEST STREET
SCALE: 1" = 10'-0"

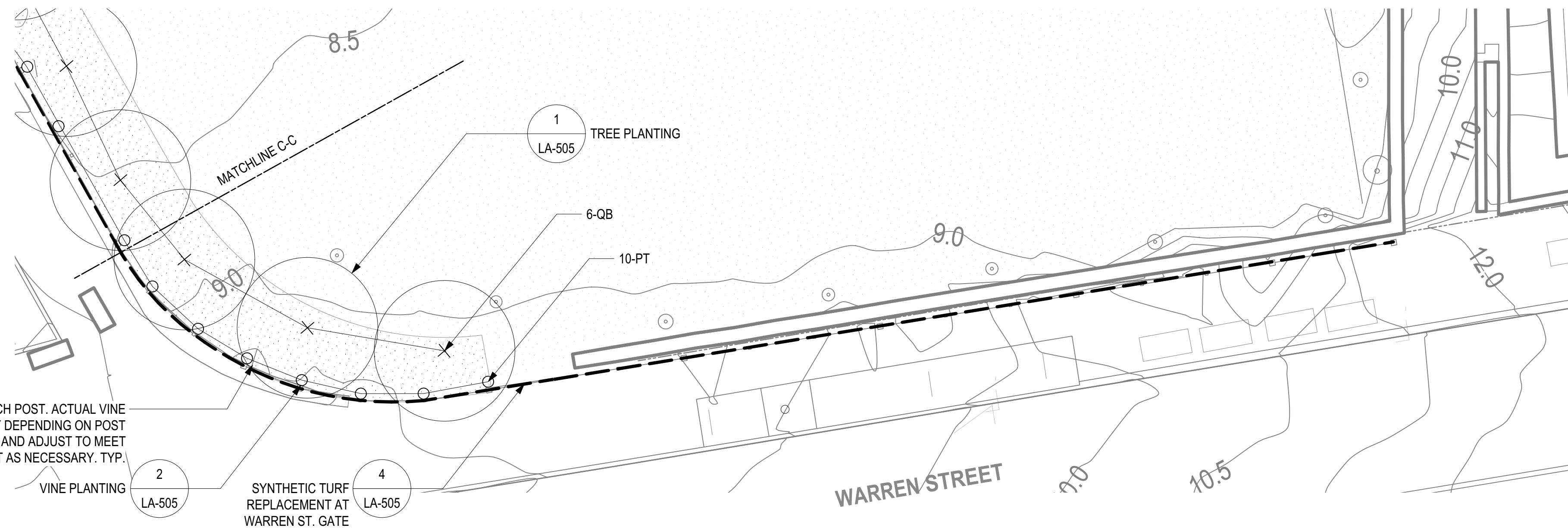

1
LA-505 TREE PLANTING

VINE PLANTING AT EACH POST. ACTUAL VINE LOCATIONS MAY VARY DEPENDING ON POST SPACING. VERIFY IN FIELD AND ADJUST TO MEET BASE OF POST AS NECESSARY. TYP.

2
LA-505 VINE PLANTING

4
LA-505 SYNTHETIC TURF REPLACEMENT AT WARREN ST. GATE

2
LA-110 PLANTING PLAN - WARREN STREET
SCALE: 1" = 10'-0"

Plant Schedule					
ID	Qty	Latin Name	Common Name	Scheduled Size	Remarks
QB	6	Quercus bicolor	Swamp Oak	4"-4.5" Cal.	
PT	35	Parthenocissus tricuspidata	Boston Ivy	1 gal.	

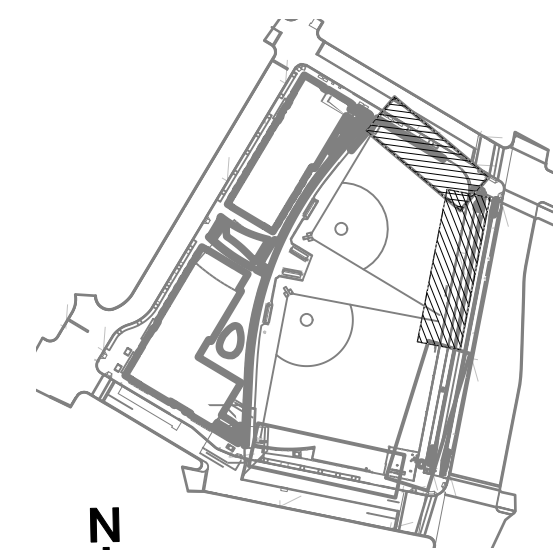

SEALS

PROJECT IDENTIFICATION



BATTERY PARK CITY
BALLFIELD AND COMMUNITY
CENTER

MARK	DATE	DESCRIPTION	BY
C	11/01/19	ISSUED FOR BID - 95%	AW
B	10/18/19	75% DESIGN SUBMITTAL	AW
A	09/06/19	50% DESIGN SUBMITTAL	AW

ISSUE BLOCK

PROJECT NO.: 3019666
DESIGNED BY: KM
DRAWN BY: KM
CHECKED BY: AW
APPROVED BY:
COPYRIGHT: STV, INC

SHEET TITLE

PLANTING
PLAN

LA-110

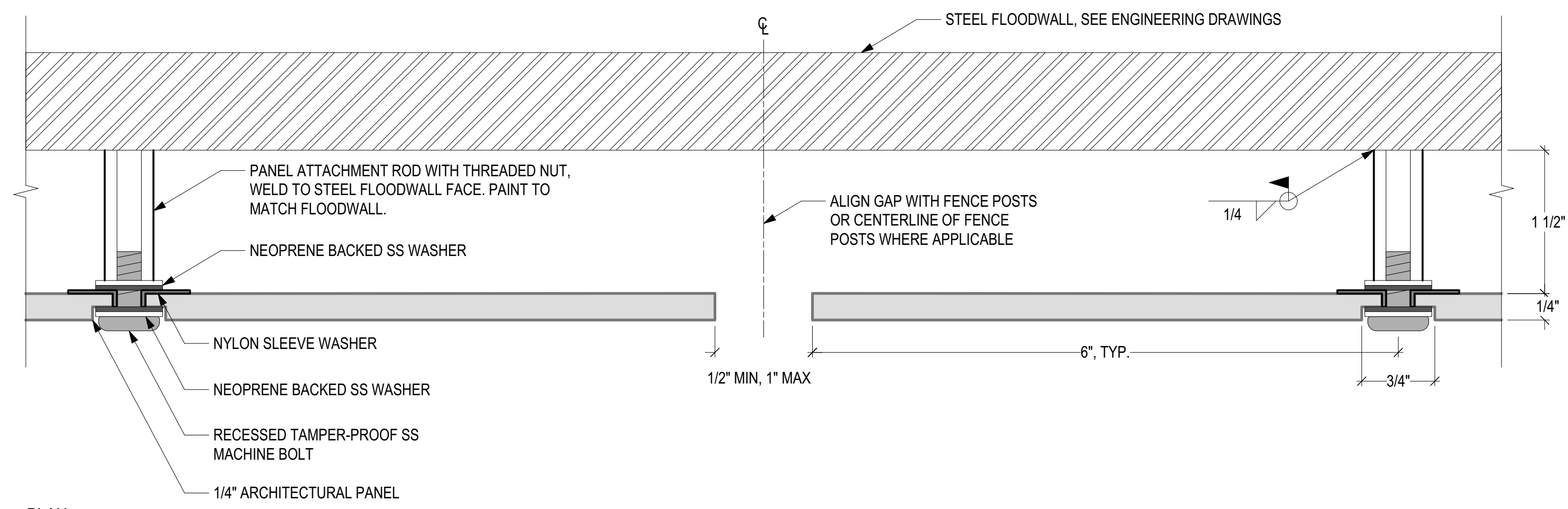

PLAN

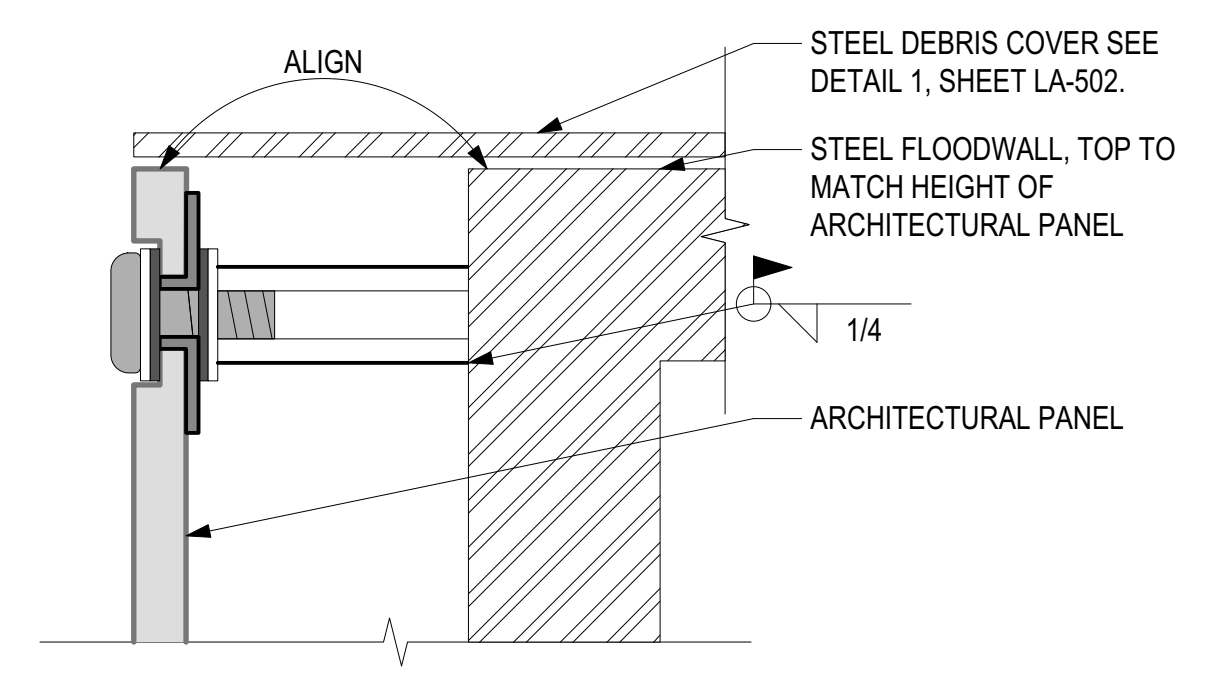

SECTION

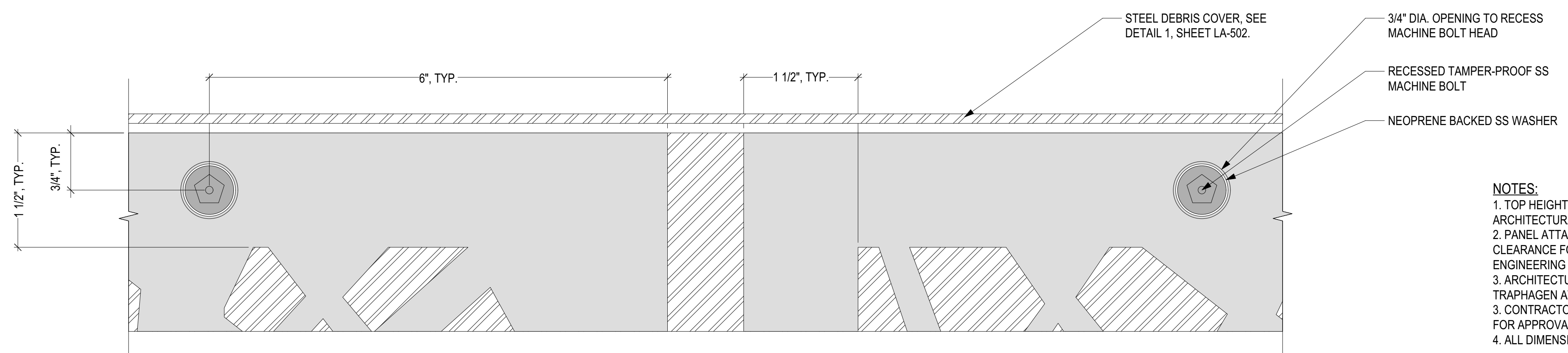

FRONT ELEVATION

- NOTES:**
1. TOP HEIGHT OF STEEL FLOODWALL TO MATCH TOP HEIGHT OF ARCHITECTURAL PANEL.
 2. PANEL ATTACHMENT ROD TO SIT 1.5" FROM STEEL FLOODWALL TO ALLOW CLEARANCE FOR STEEL FLOODWALL ATTACHMENT HARDWARE. SEE ENGINEERING DRAWINGS.
 3. ARCHITECTURAL PANEL PATTERN TO BE 'STIX' BY ANOVA. CONTACT DAVID TRAPHAGEN AT ANOVA FOR MORE INFORMATION (312) 405-1773.
 3. CONTRACTOR TO SUBMIT SHOP DRAWINGS TO LANDSCAPE ARCHITECT FOR APPROVAL PRIOR TO FABRICATION.
 4. ALL DIMENSIONS TO BE VERIFIED IN FIELD.

1 ARCHITECTURAL PANEL ATTACHMENT TO STEEL FLOOD WALL
SCALE: 1:1

- NOTES:**
1. CONTRACTOR TO SUBMIT SHOP DRAWINGS TO LANDSCAPE ARCHITECT FOR APPROVAL PRIOR TO FABRICATION.
 2. ALL DIMENSIONS TO BE VERIFIED IN FIELD.

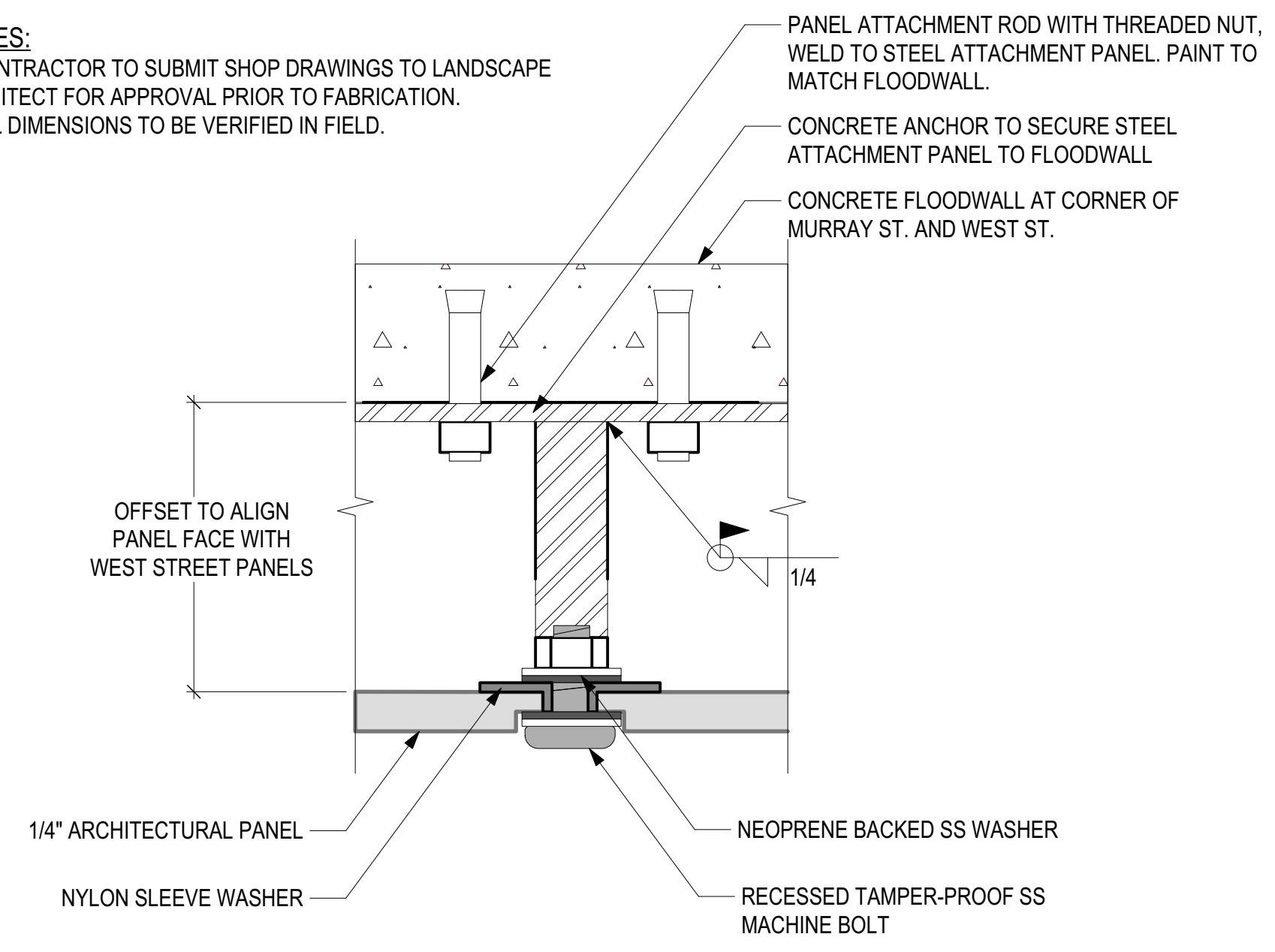

PLAN

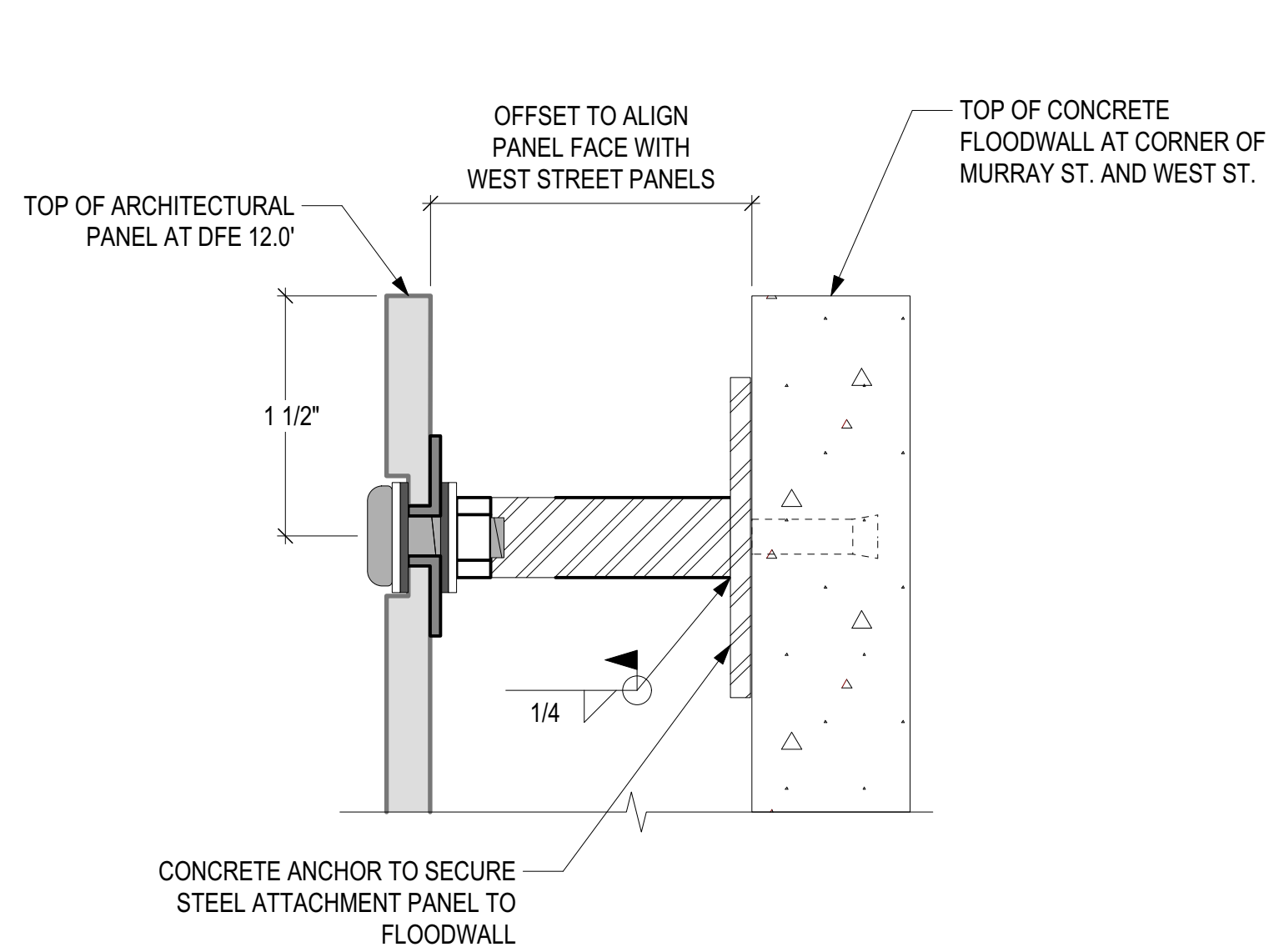

SECTION

NOTE:
'LA' SERIES DRAWINGS FOR ARCHITECTURAL PANELS ONLY. SEE 'S' SERIES FOR ALL STEEL FLOODWALL INFORMATION AND DETAILS.

2 ARCHITECTURAL PANEL ATTACHMENT TO CONCRETE FLOOD WALL
SCALE: 1:1

STV 100 Years
 STV INCORPORATED
 225 PARK AVENUE SOUTH
 5TH FLOOR
 NEW YORK, NY 10003
 www.stvinc.com

CONSULTANTS
SITWORKS
 LANDSCAPE ARCHITECTURE, LLC
 SITWORKS
 150 WEST 28TH STREET
 SUITE 605
 NEW YORK, NY 10001
 www.sitworks.com

SEALS

PROJECT IDENTIFICATION

NEW YORK STATE OF OPPORTUNITY
Battery Park City Authority
 BATTERY PARK CITY
 BALLFIELD AND COMMUNITY CENTER

MARK	DATE	DESCRIPTION	BY
C	11/01/19	ISSUED FOR BID - 95%	AW
B	10/18/19	75% DESIGN SUBMITTAL	AW
A	09/06/19	50% DESIGN SUBMITTAL	AW

ISSUE BLOCK

PROJECT NO.:	3019666
DESIGNED BY:	KM
DRAWN BY:	KM
CHECKED BY:	AW
APPROVED BY:	
COPYRIGHT:	STV, INC

ARCHITECTURAL
 PANEL
 DETAILS- A

LA-501

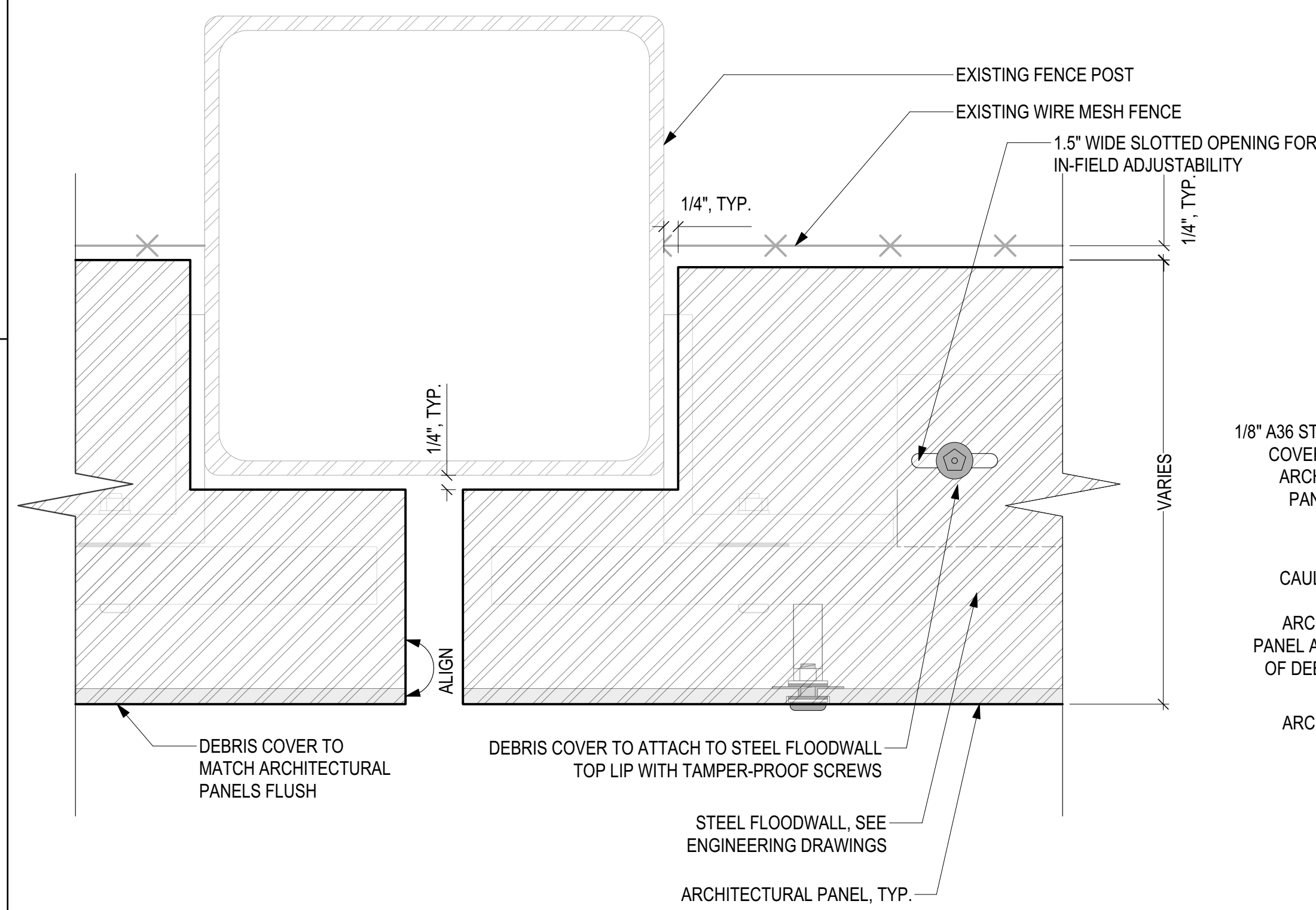

PLAN

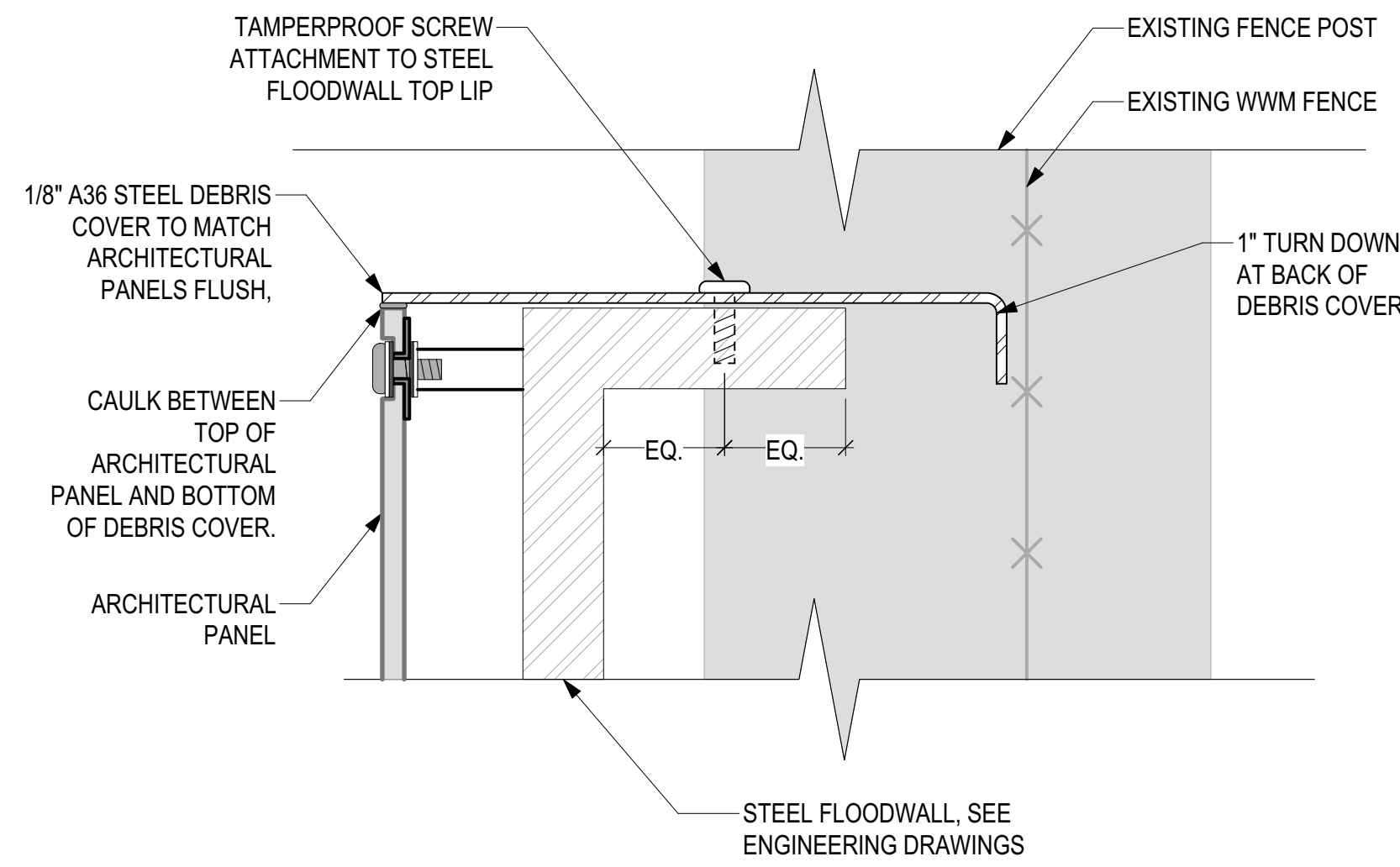

SECTION

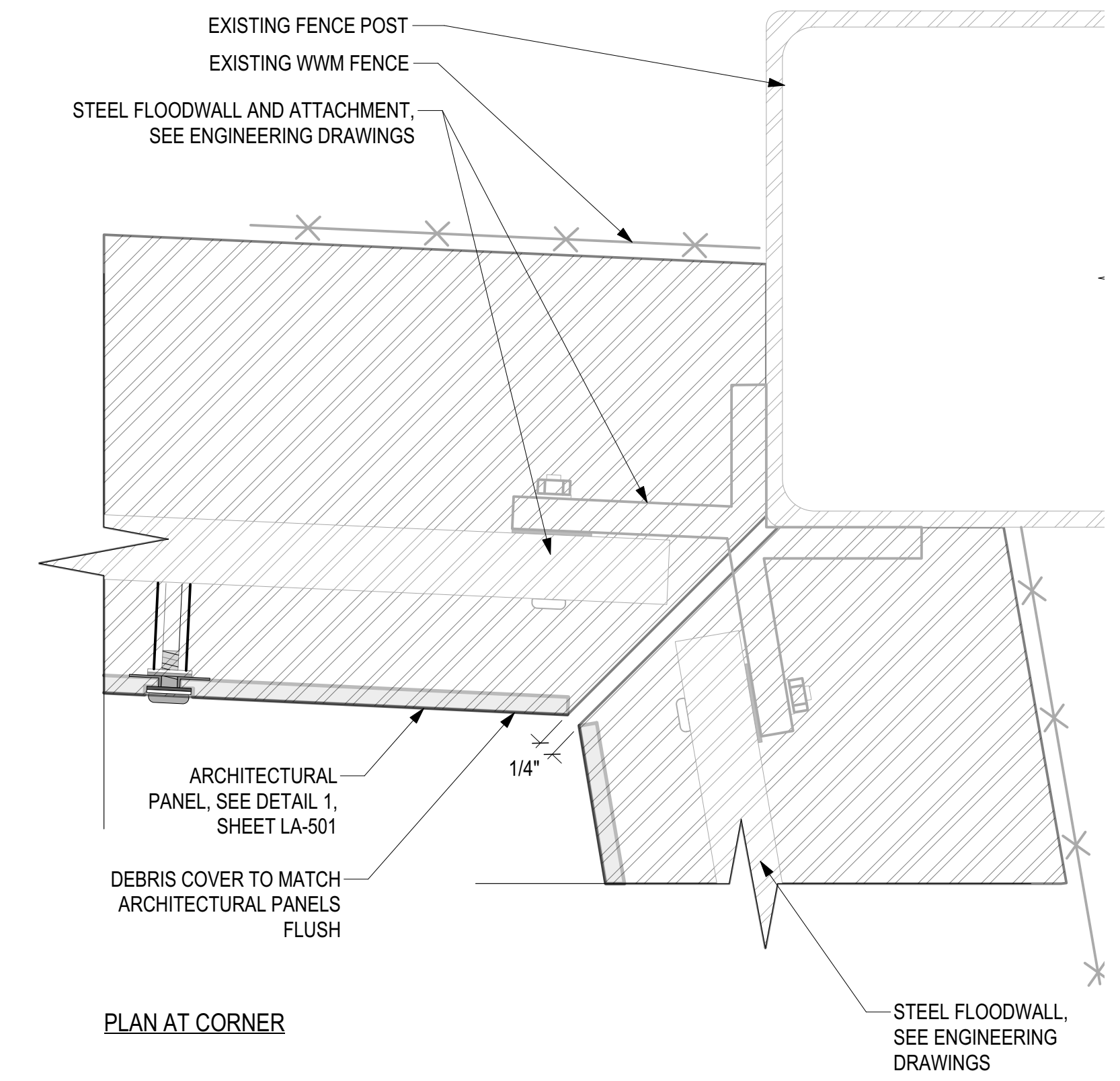

PLAN AT CORNER

- NOTES:
1. DEBRIS COVER SCREWS TO BE EQUALLY SPACED EVERY 12", MIN.
 2. DEBRIS COVER TO MAINTAIN 1/4" GAP BETWEEN FACES OF FENCE POSTS AND WIRE MESH FENCE.

1 DEBRIS COVER ATTACHMENT
SCALE: 1:2

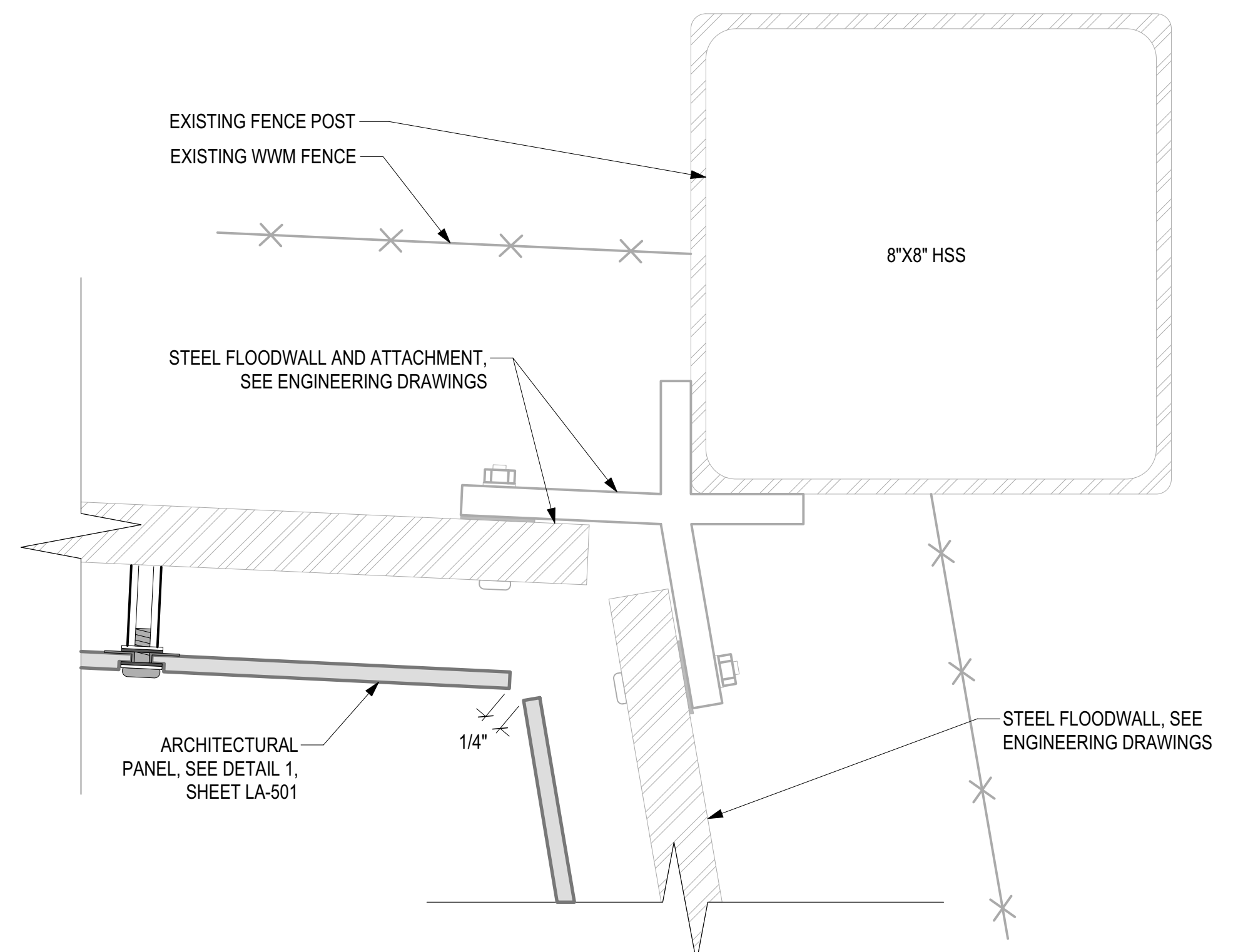

3 ARCHITECTURAL PANEL ATTACHMENT AT INTERIOR CORNER
SCALE: 1:2

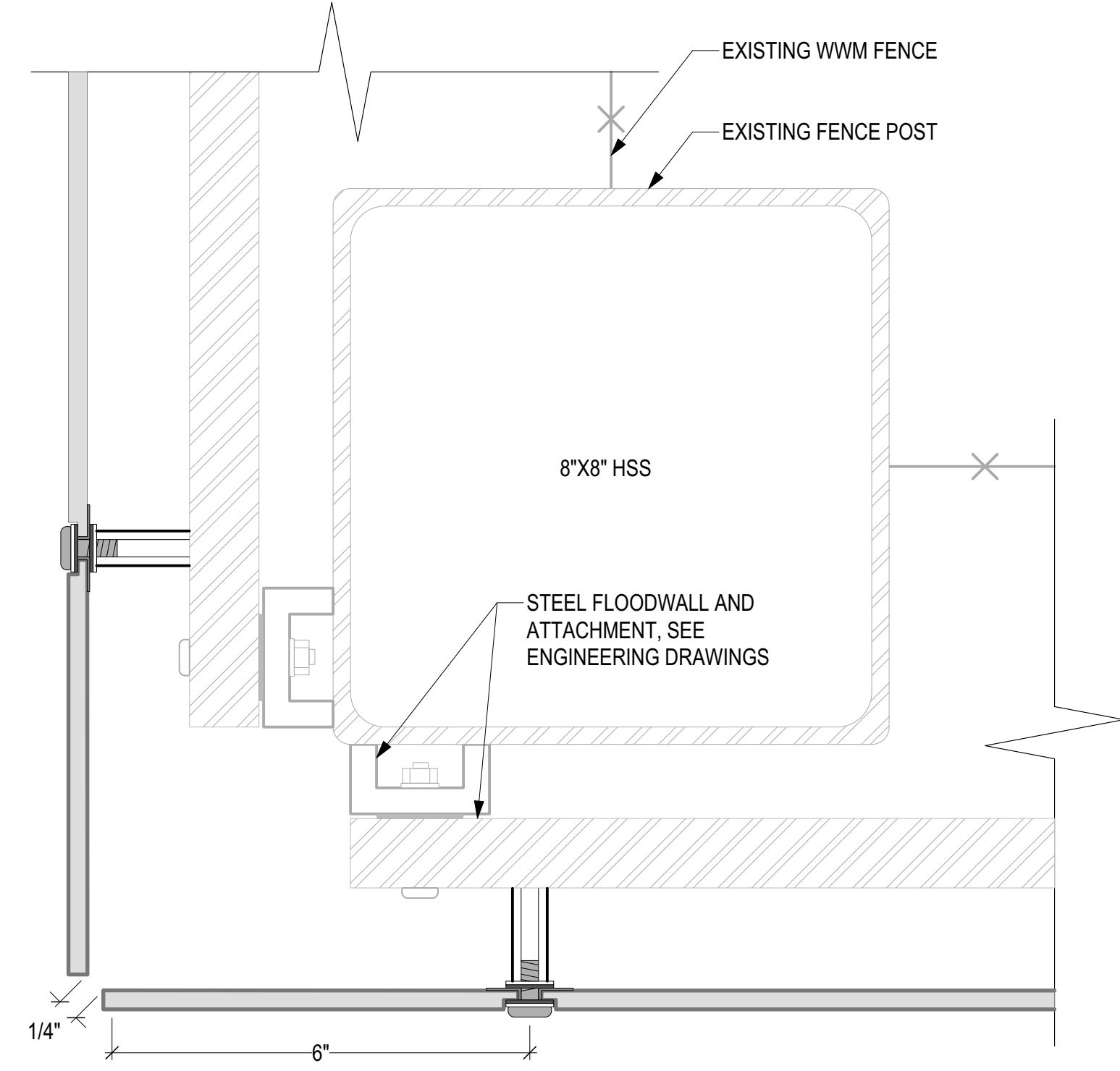

2 ARCHITECTURAL PANEL ATTACHMENT AT EXTERIOR CORNER
SCALE: 1:2

NOTE:
'LA' SERIES DRAWINGS FOR ARCHITECTURAL PANELS ONLY. SEE 'S' SERIES FOR ALL STEEL FLOODWALL INFORMATION AND DETAILS.

SEALS

PROJECT IDENTIFICATION



BATTERY PARK CITY
BALLFIELD AND COMMUNITY CENTER

MARK	DATE	DESCRIPTION	BY
C	11/01/19	ISSUED FOR BID - 95%	AW
B	10/18/19	75% DESIGN SUBMITTAL	AW
A	09/06/19	50% DESIGN SUBMITTAL	AW

ISSUE BLOCK

PROJECT NO.:	3019666
DESIGNED BY:	KM
DRAWN BY:	KM
CHECKED BY:	AW
APPROVED BY:	
COPYRIGHT:	STV, INC
SHEET TITLE	

ARCHITECTURAL
PANEL
DETAILS- B

LA-502

- NOTES:**
1. TOP OF STEEL FLOODWALL AND ARCHITECTURAL PANEL TO SIT FLUSH.
 2. DISTANCE BETWEEN TOP OF CURB AND BOTTOM OF ARCHITECTURAL PANELS VARIES BASED ON TOPOGRAPHY, VERIFY DIMENSIONS IN FIELD.
 3. ELEVATIONS SHOW VARIATIONS AT EACH STREET WITH STIX PATTERN.

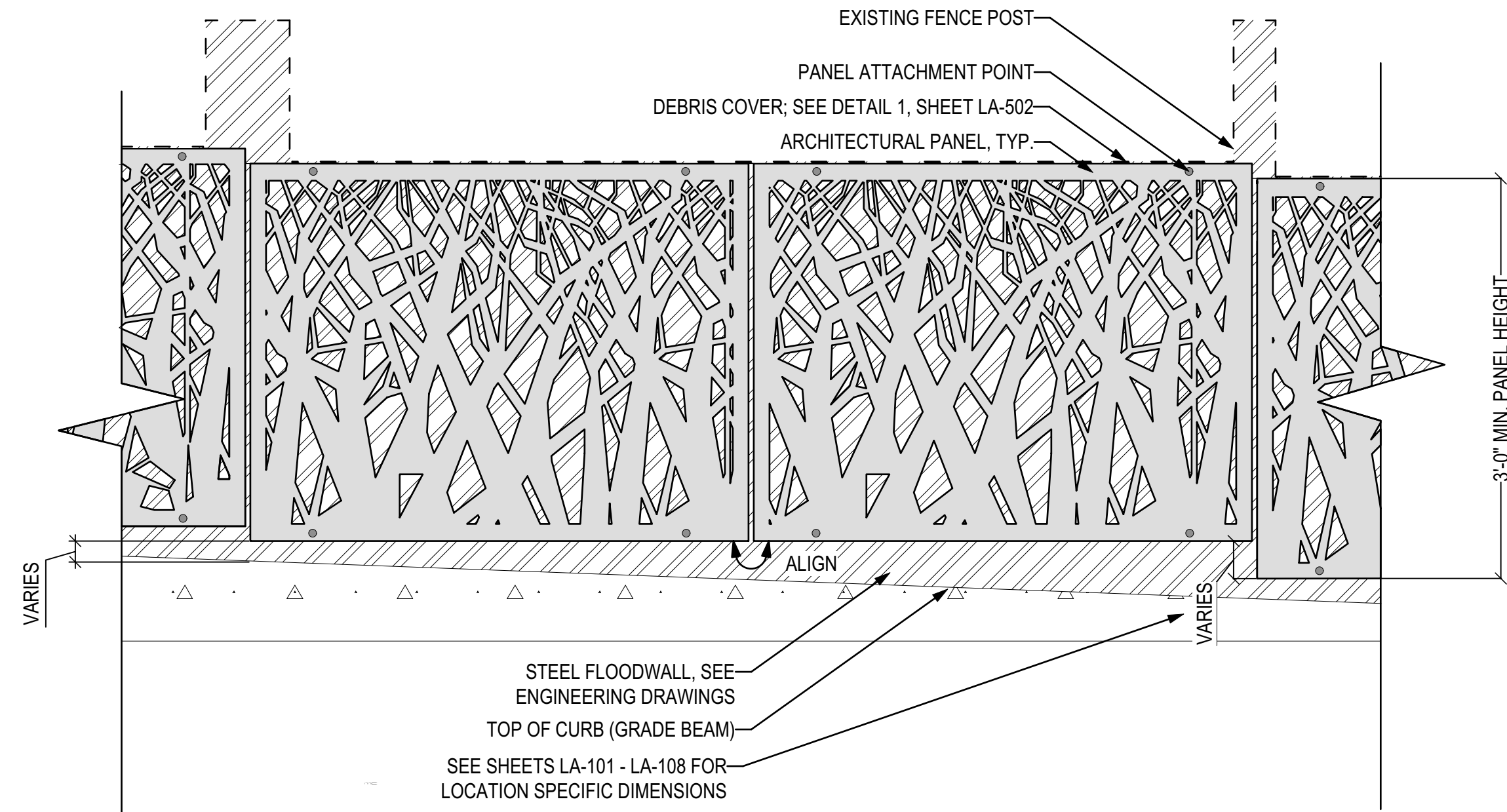

1
LA-503
TYPICAL ELEVATION MURRAY STREET
SCALE: 1" = 1'-0"

NOTE:
'LA' SERIES DRAWINGS FOR ARCHITECTURAL PANELS ONLY. SEE 'S' SERIES FOR ALL STEEL FLOODWALL INFORMATION AND DETAILS.

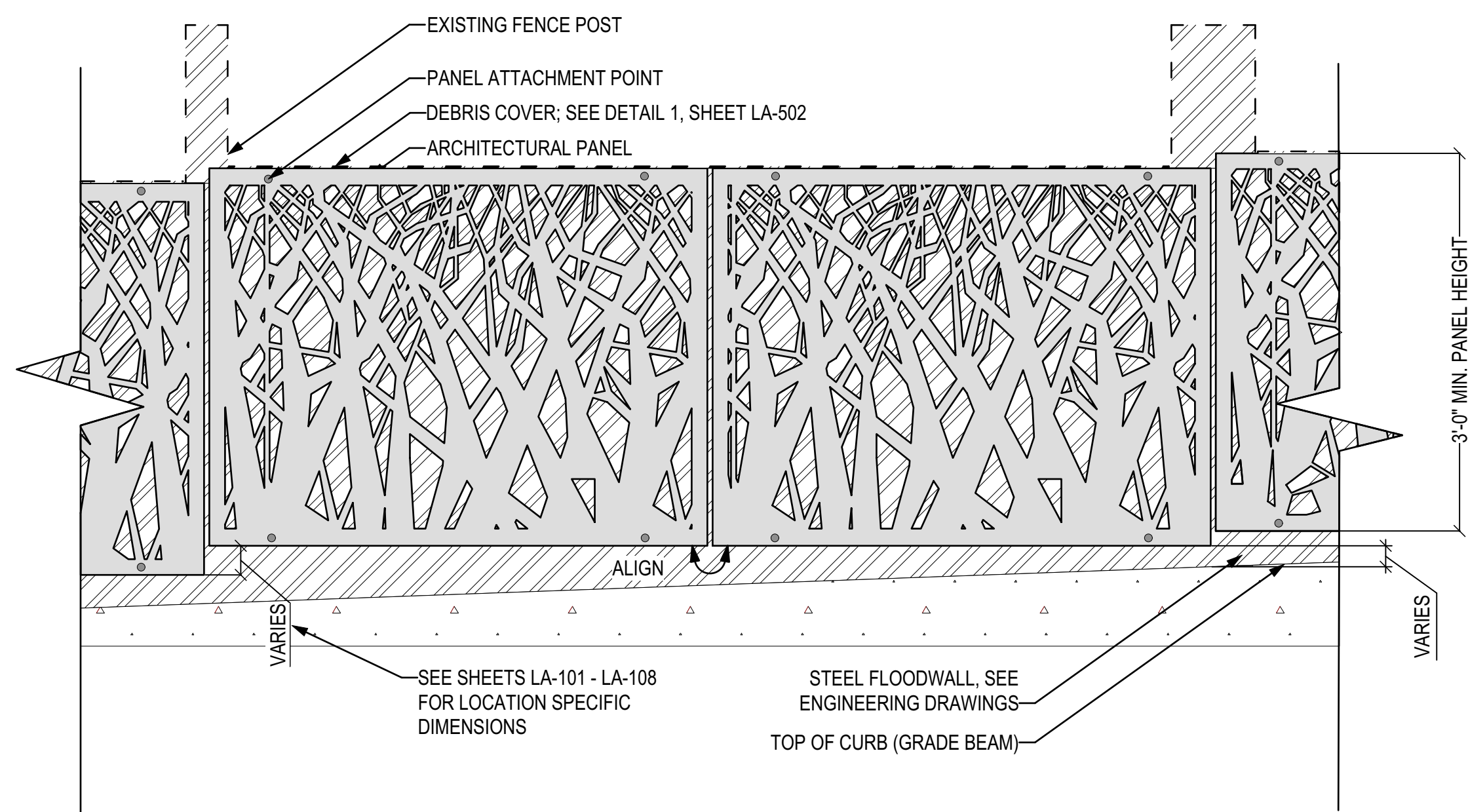

3
LA-503
TYPICAL ELEVATION WARREN STREET
SCALE: 1" = 1'-0"

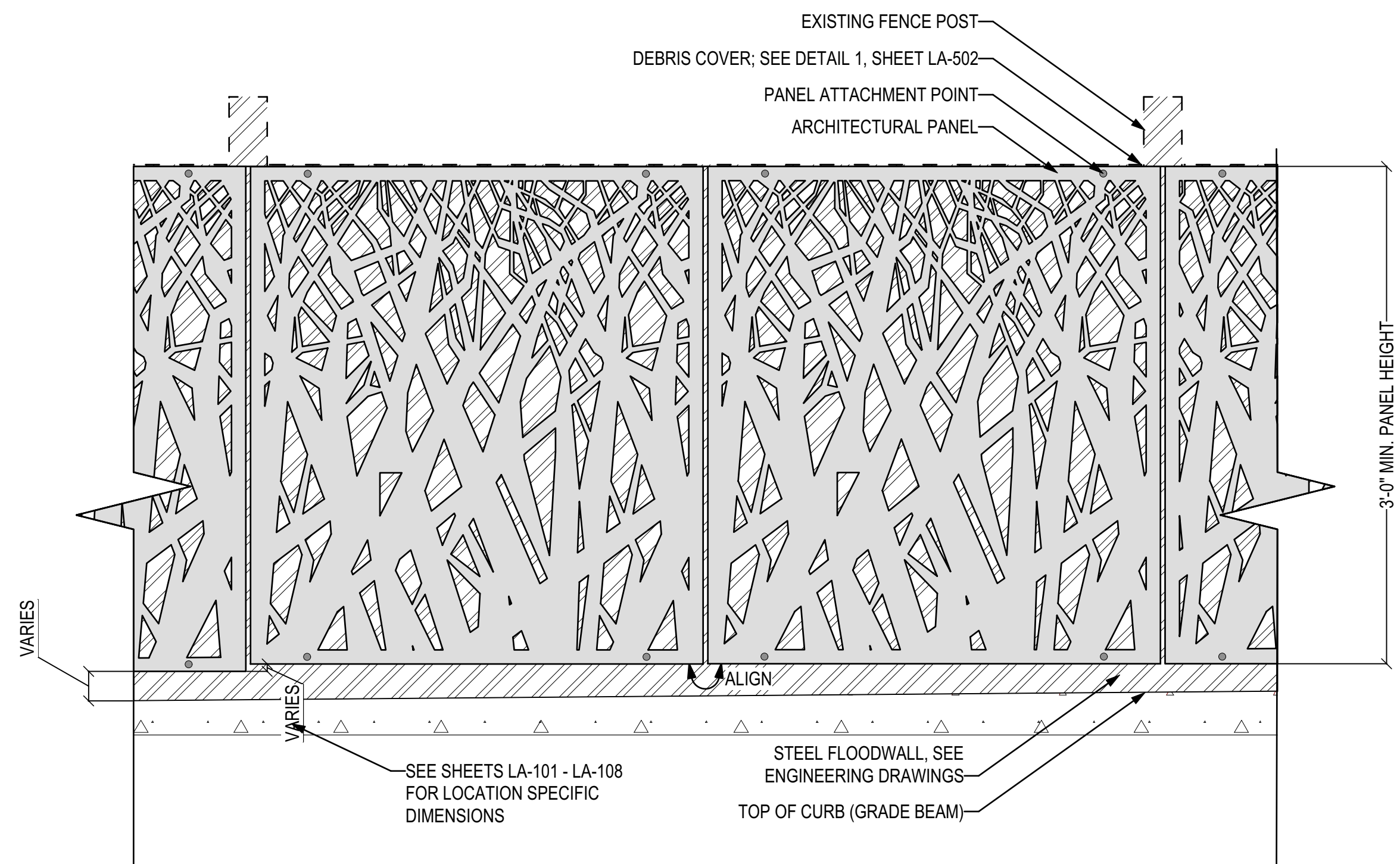

2
LA-503
TYPICAL ELEVATION WEST STREET
SCALE: 1" = 1'-0"

SEALS

PROJECT IDENTIFICATION

NEW YORK STATE OF OPPORTUNITY
Battery Park City Authority
BATTERY PARK CITY
BALLFIELD AND COMMUNITY CENTER

MARK	DATE	DESCRIPTION	BY
C	11/01/19	ISSUED FOR BID - 95%	AW
B	10/18/19	75% DESIGN SUBMITTAL	AW
A	09/06/19	50% DESIGN SUBMITTAL	AW

ISSUE BLOCK

PROJECT NO.:	3019666
DESIGNED BY:	KM
DRAWN BY:	KM
CHECKED BY:	AW
APPROVED BY:	
COPYRIGHT:	STV, INC

SHEET TITLE

ARCHITECTURAL
PANEL
ENLARGEMENTS

LA-503

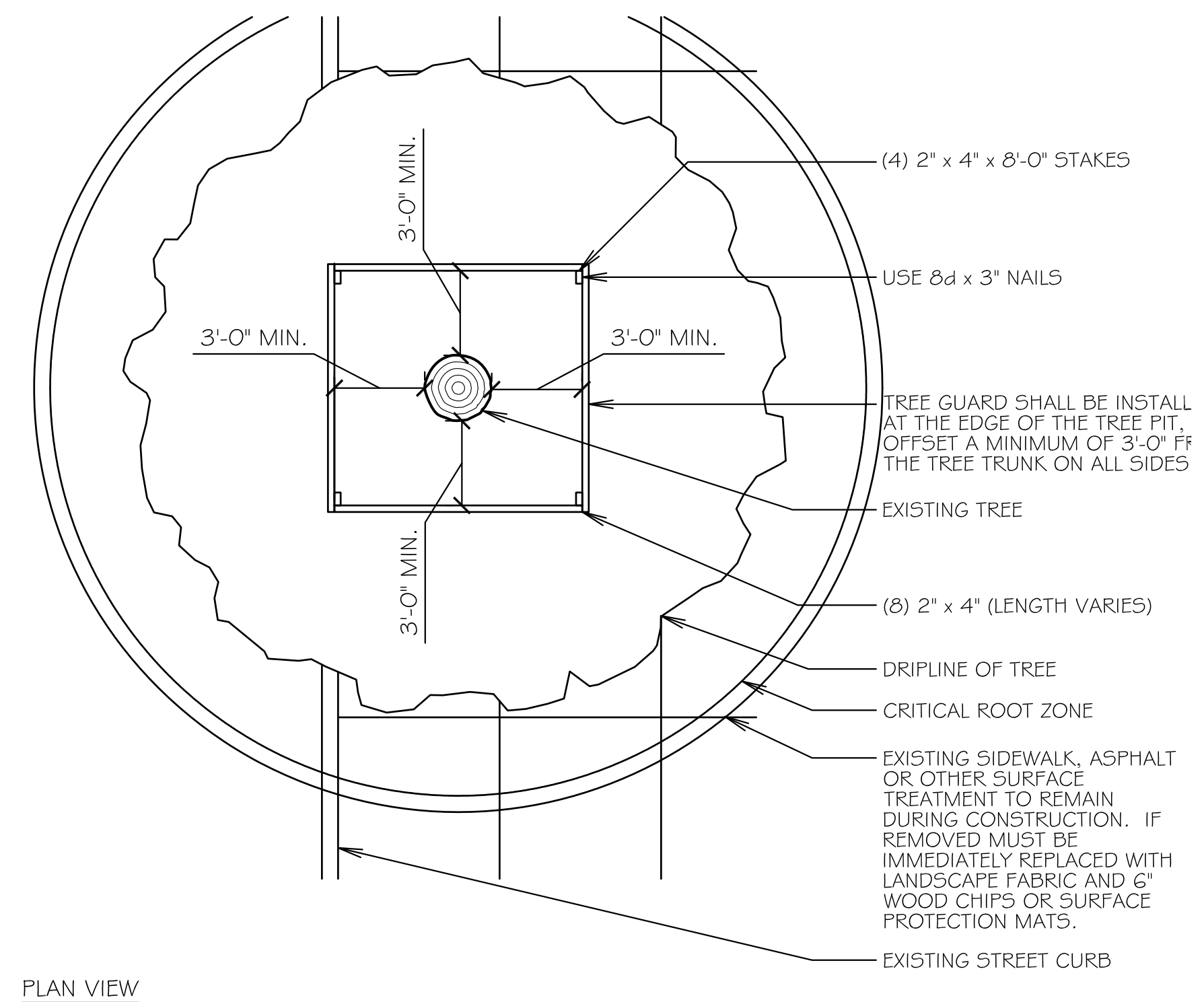
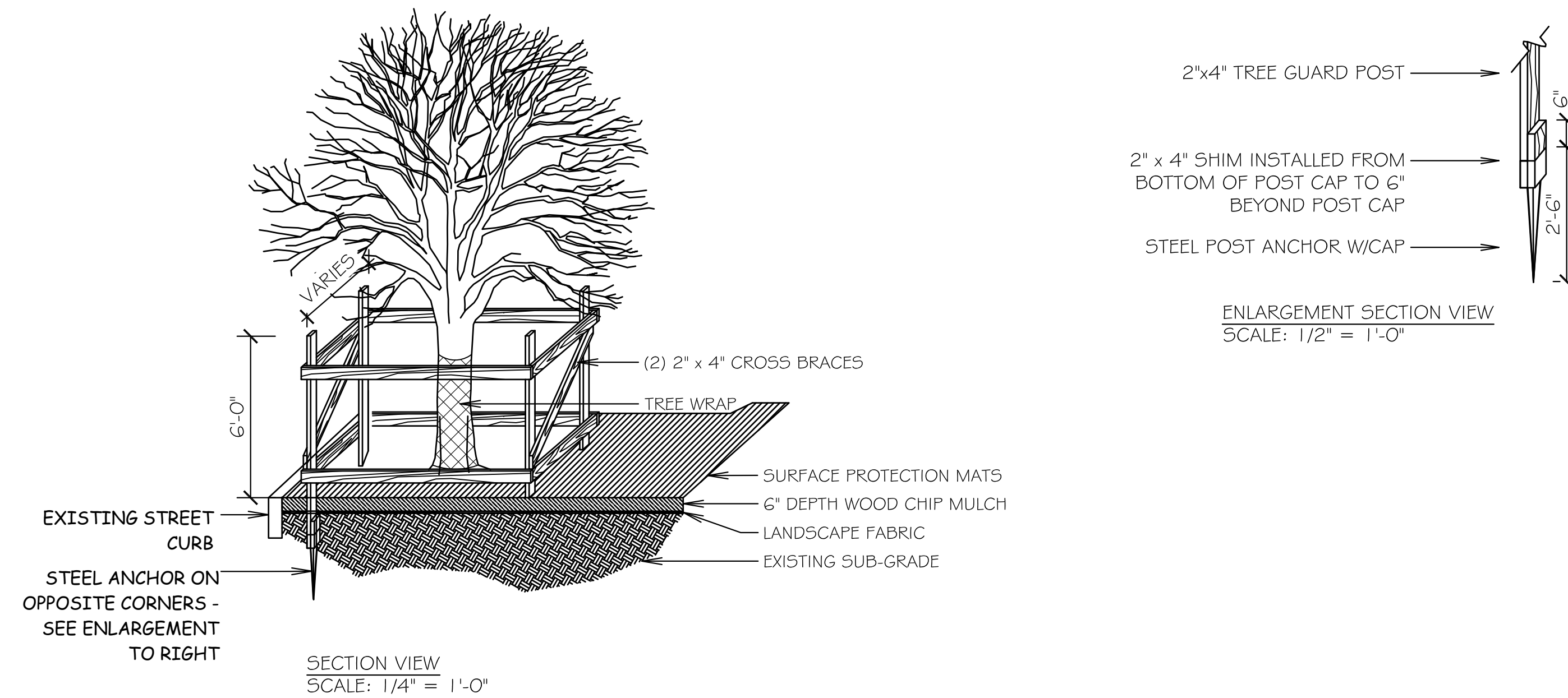

1
LA-504 TREE GUARD WITH CRITICAL ROOT ZONE GROUND PROTECTION
AS SHOWN

SEALS

PROJECT IDENTIFICATION



BATTERY PARK CITY
BALLFIELD AND COMMUNITY
CENTER

MARK	DATE	DESCRIPTION	BY
C	11/01/19	ISSUED FOR BID - 95%	AW
B	10/18/19	75% DESIGN SUBMITTAL	AW
A	09/06/19	50% DESIGN SUBMITTAL	AW

ISSUE BLOCK

PROJECT NO.:	3019666
DESIGNED BY:	KM
DRAWN BY:	KM
CHECKED BY:	AW
APPROVED BY:	
COPYRIGHT:	STV, INC

SHEET TITLE

TREE
PROTECTION
DETAILS

LA-504

MARK	DATE	DESCRIPTION	BY
C	11/01/19	ISSUED FOR BID - 95%	AW
B	10/18/19	75% DESIGN SUBMITTAL	AW
A	09/06/19	50% DESIGN SUBMITTAL	AW

ISSUE BLOCK

PROJECT NO.:	3019666
DESIGNED BY:	KM
DRAWN BY:	KM
CHECKED BY:	AW
APPROVED BY:	
COPYRIGHT:	STV, INC

SHEET TITLE

PLANTING DETAILS

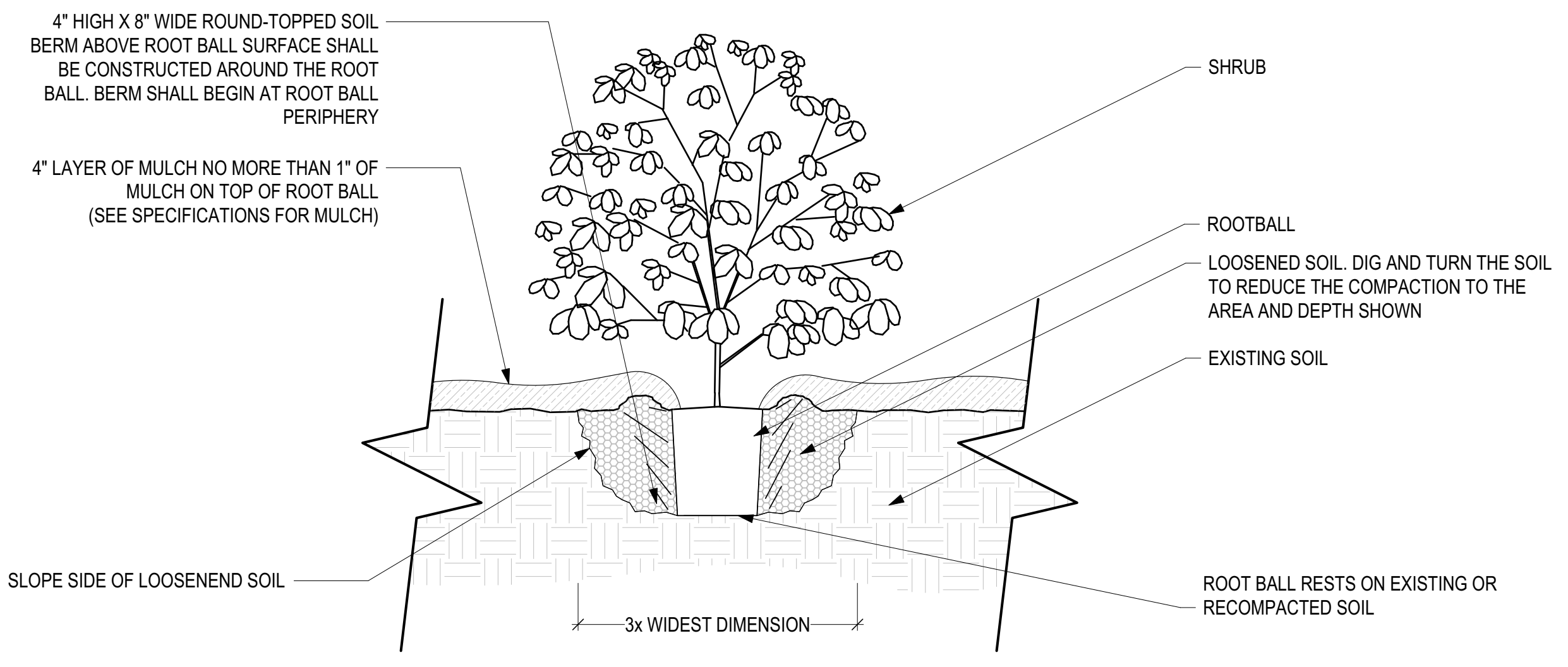

NOTES:
1. SHRUBS SHALL BE OF QUALITY PRESCRIBED IN THE ROOT OBSERVATIONS DETAIL AND SPECIFICATIONS.
2. SEE SPECIFICATIONS FOR FURTHER REQUIREMENTS RELATED TO THIS DETAIL.

3 SHRUB PLANTING
LA-505 SCALE: 3/4" = 1'-0"

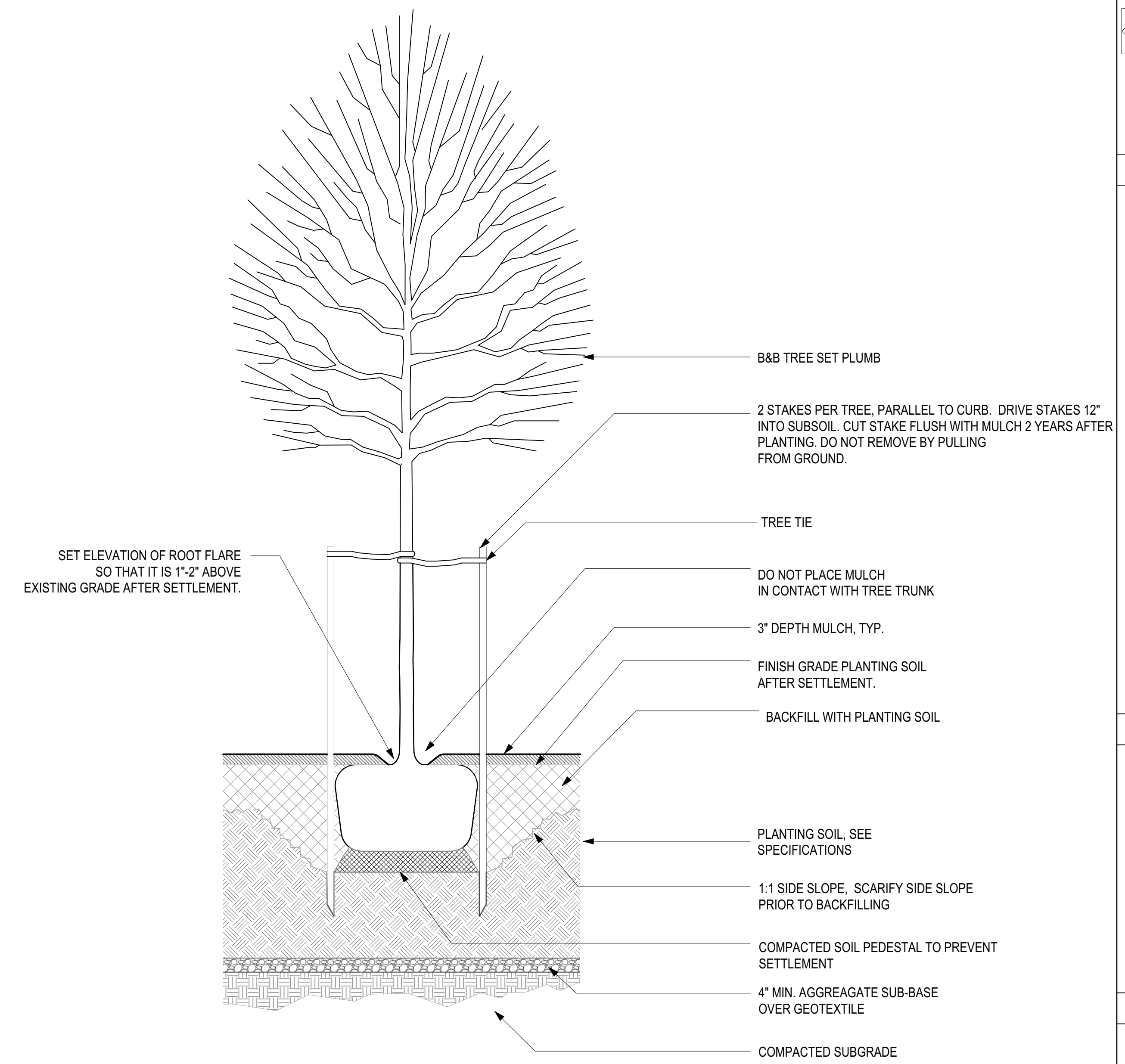

1 TREE PLANTING
LA-505 SCALE: 1/2" = 1'-0"

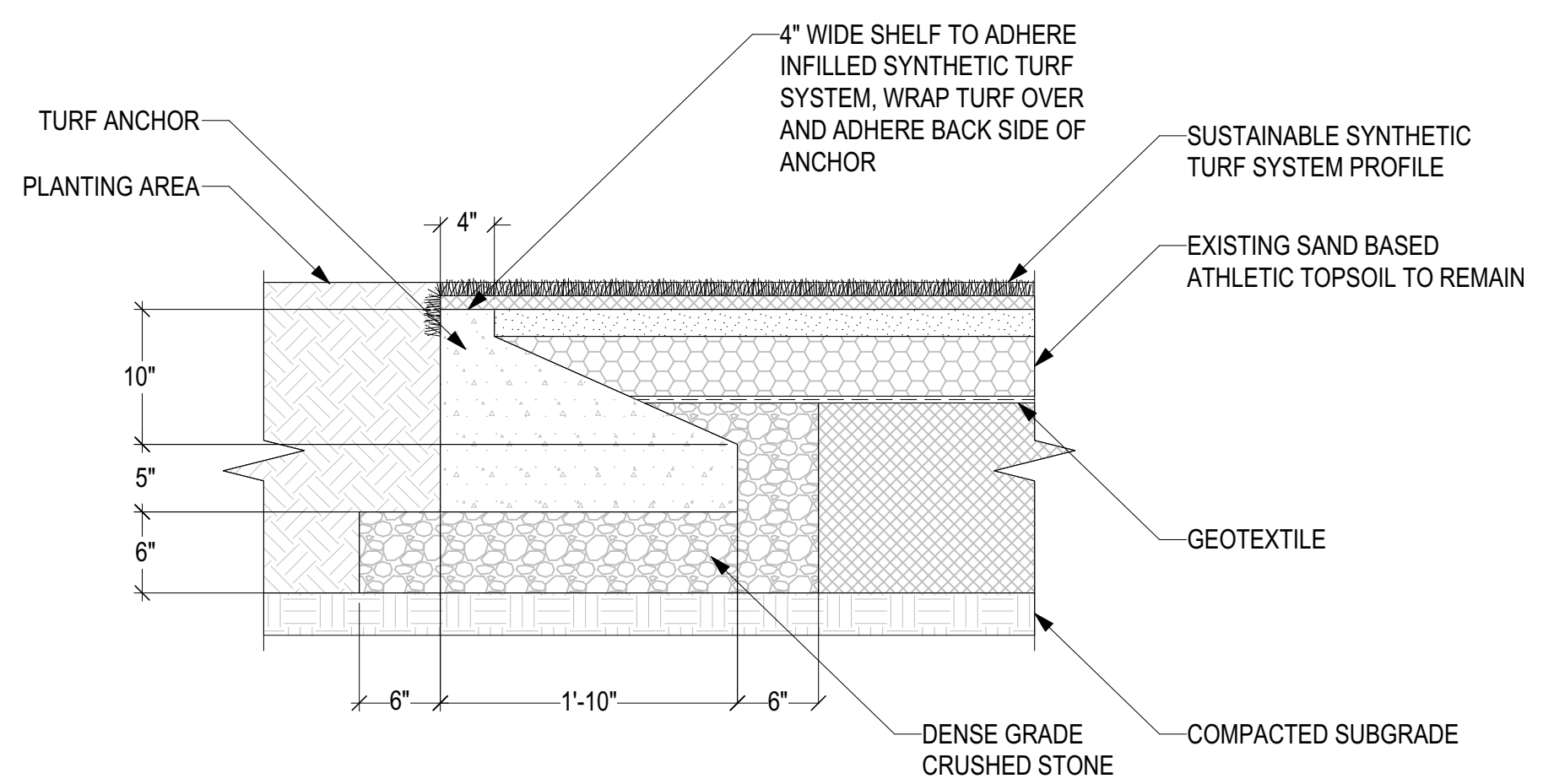

NOTE:
1. PEEL BACK SYNTHETIC TURF WHERE DISTURBED BY CONSTRUCTION AND REPLACE TO MATCH EXISTING CONDITION.

4 SYNTHETIC TURF REPLACEMENT AT WARREN ST. GATE
LA-505 SCALE: 1" = 1'-0"

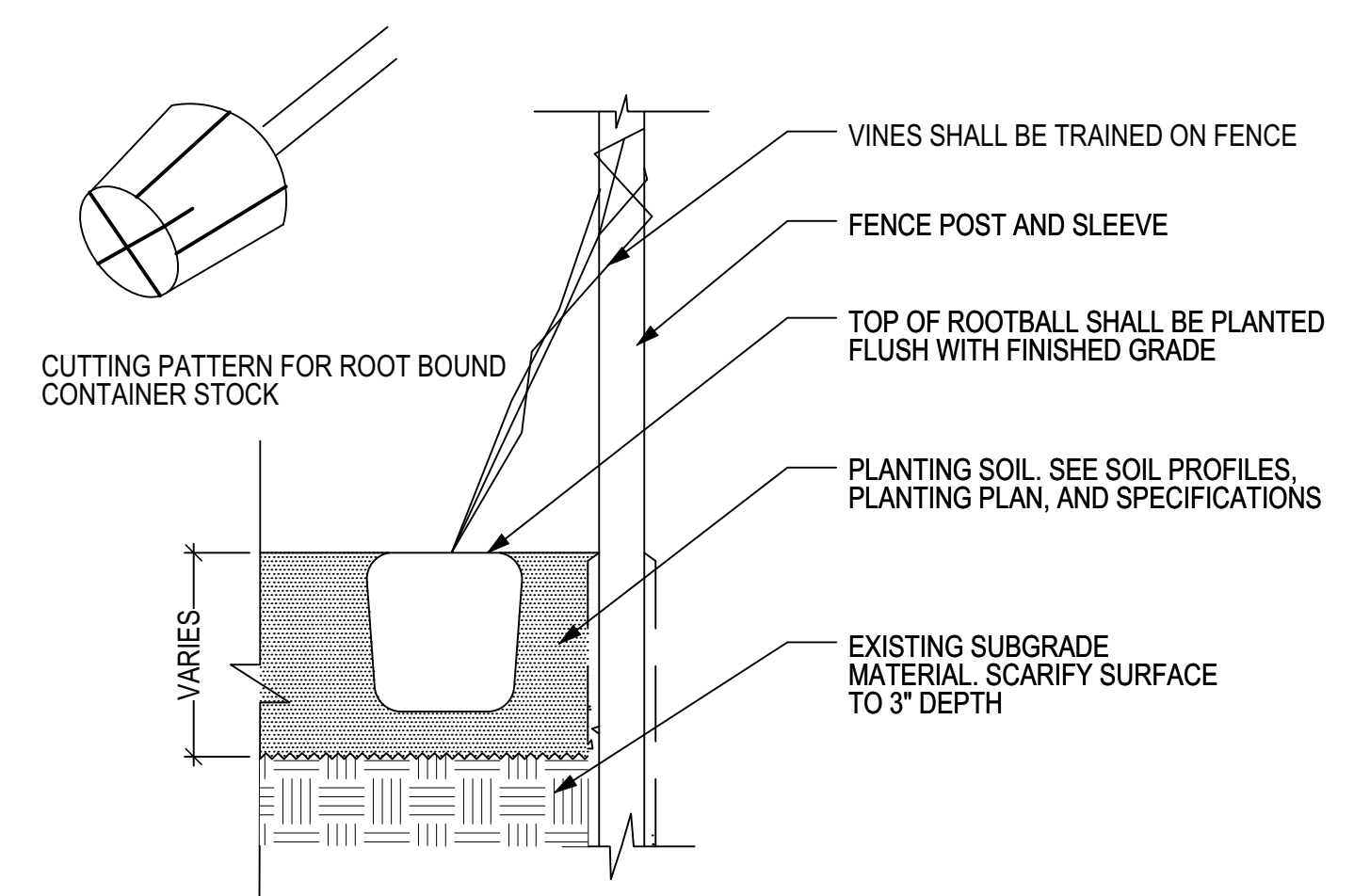

2 VINE PLANTING
LA-505 SCALE: 3/4" = 1'-0"

GENERAL NOTES:

1. THE FLOODWALL STRUCTURES ARE DESIGNED IN ACCORDANCE WITH THE 2014 BUILDING CODE OF THE CITY OF NEW YORK (NYCBC 2014) AND ASSOCIATED REFERENCE STANDARDS.
2. THESE DRAWINGS SHALL BE USED IN CONJUNCTION WITH THE LANDSCAPE ARCHITECTURE AND CIVIL DRAWINGS AND SPECIFICATIONS.
3. THE METHODS, PROCEDURES AND SEQUENCES OF CONSTRUCTION ARE THE RESPONSIBILITY OF THE GENERAL CONTRACTOR.
4. THE PRESENCE OF THE ENGINEER OR OWNER REPRESENTATIVES AT THE JOBSITE SHALL NOT CHANGE ANY RESPONSIBILITY FOR THE CONTRACTOR'S MEANS AND METHODS OF CONSTRUCTION AND FOR ALL SAFETY PRECAUTIONS ON THE JOB SITE.
5. ANY SUBSTITUTIONS OR ALTERNATES PROPOSED BY THE CONTRACTOR MAY BE USED IF SUCH SUBSTITUTIONS OR ALTERNATES ARE SUBMITTED IN WRITING TO THE ENGINEER FOR REVIEW AND ACCEPTANCE. THE CONTRACTOR SHALL BE RESPONSIBLE FOR AND COVER ANY ADDITIONAL EXPENSES FOR THE DESIGN OF SUCH ALTERNATES AND SUBSTITUTIONS.
6. THE GENERAL CONTRACTOR SHALL TAKE ALL NECESSARY PRECAUTIONS TO MAINTAIN AND ENSURE THE INTEGRITY OF THE EXISTING STRUCTURE AT ALL STAGES OF CONSTRUCTION. DESIGN OF ANY NECESSARY MEASURES TO MAINTAIN THIS INTEGRITY IS SOLELY THE RESPONSIBILITY OF THE CONTRACTOR.
7. DETAILS HAVE BEEN PREPARED BASED UPON RECORD DRAWINGS AND VISUAL OBSERVATIONS. CONTRACTOR IS TO VERIFY ALL ELEVATIONS AND DIMENSIONS IN THE FIELD FOR INCORPORATION INTO THE SHOP DRAWINGS. NOTIFY ENGINEER IMMEDIATELY OF AN MAJOR DIMENSIONAL DISCREPANCIES.
8. DEFICIENT WORK SHALL BE REPLACED OR REPAIRED BY CONTRACTOR, AS DETERMINED BY THE ENGINEER, AT NO COST TO THE OWNER.
9. ALL ELEVATIONS SHOWN ARE REFERENCED TO THE NORTH AMERICAN VERTICAL DATUM OF 1988 (NAVD88).

DESIGN CRITERIA:

1. WIND LOADS (ASCE 7-05):
 BASIC WIND SPEED.....98 MPH
 EXPOSURE CLASSIFICATION.....D
 RISK CATEGORY.....CATEGORY II
2. FLOOD AND WAVE LOADS (ASCE 7-10):
 FEMA FIRM BASE FLOOD ELEVATION.....EL. +11.0'
 DESIGN FLOOD ELEVATION.....EL. + 12.0'
 RISK CATEGORY.....CATEGORY II
 WATER DENSITY.....64 PCF
 SEE S-003 FOR ADDITIONAL FLOOD LOAD INFORMATION.

SPECIAL CONSTRUCTION CONSIDERATIONS:

1. UNDERGROUND UTILITIES ARE SHOWN AS PER THE AVAILABLE RECORD DRAWINGS. THE CONTRACTOR IS RESPONSIBLE FOR PERFORMING AN UNDERGROUND UTILITY INVESTIGATION PRIOR TO CONSTRUCTION OF THE PERIMETER WALL. IN AREAS WHERE A GRADE BEAM IS TO BE INSTALLED, EXCAVATION DEPTH SHALL BE HAND DUG. IN AREAS OF A NEW FOUNDATION WALL, HAND DIG A 5-FT DEEP TRENCH TO ENSURE NO UTILITY CONFLICTS PRIOR TO COMPLETING THE EXCAVATION. CONTRACTOR IS RESPONSIBLE TO REPAIR ANY UTILITIES DAMAGED DURING CONSTRUCTION.
2. EXCAVATION FOR NEW FOUNDATION ELEMENTS OCCURS BETWEEN EXISTING SHALLOW FENCE FOUNDATIONS. EXISTING FENCE IS TO BE FULLY SHORED TO ENSURE MOVEMENT AND UNDERMINING IS MINIMAL DURING ALL CONSTRUCTION ACTIVITIES. SHORING WILL LIKELY EXTEND INTO THE ADJACENT SIDEWALK OR BALLFIELD AND MUST BE COORDINATED WITH THESE STAKEHOLDERS FOR ACCEPTABLE OUTAGES, EXTENTS, AND LOCATIONS. SHORING SUBMITTAL SHALL BE SIGNED AND SEALED BY A NY PE AND SUBMITTED TO THE ENGINEER AND STAKEHOLDERS FOR REVIEW AND APPROVAL. SUBMITTAL MUST CLEARLY DENOTE TIMING AND PHASING OF EACH SHORING LOCATION. THIS PHASING SHALL CORRESPOND TO THAT LISTED IN THE DIVISION 1 SPECIFICATIONS.
3. THE PROJECT IS INTENDED TO CREATE A FULLY SEALED STRUCTURAL PERIMETER TO ELEVATION +12-FT. AS SUCH ALL DETAILS AND MATERIAL INTERSECTIONS SHALL HAVE NO VOIDS. ALL MATERIAL INTERSECTIONS SHALL HAVE AN EXPANSIVE BENTONITE STRIP OR APPLIED SEALANT BY SIKA OR APPROVED EQUAL. NOTIFY THE ENGINEER IMMEDIATELY IF A DETAILING GAP BETWEEN ELEMENTS EXISTS. ANY TEMPORARY GAPS, FORM TIE OR OTHER HOLES USED FOR ERECTION MUST BE CLOSED IN A WATERTIGHT MANNER AS APPROVED BY THE ENGINEER.
4. THIS PROJECT WORKS AROUND MANY EXISTING FENCE ELEMENTS. THE INTENTION IS TO SALVAGE AND REUSE AS MANY EXISTING ELEMENTS AS POSSIBLE UNLESS COST PROHIBITIVE. ALL NEW STEEL IS GALVANIZED, AND GALVANIZING TOUCH UP ON ALL STEEL SHALL BE PROVIDED WHERE DAMAGED. EXISTING FENCE MESH CAN BE REMOVED FOR ACCESS TO PERFORM WORK AT CONTRACTOR'S OPTION. FOR USE IN DETERMINATION, AVAILABLE EXISTING DRAWINGS ARE ATTACHED FOR REFERENCE.

SPECIAL CONSTRUCTION CONSIDERATIONS (CONTINUED):

5. A DETAILED SURVEY SHALL BE COMPLETED TO VERIFY EXISTING DIMENSIONS AND ALIGNMENT OF FENCE MEMBERS, FENCE FOUNDATIONS, AND DIMENSIONS TO ADJACENT STRUCTURES SUCH AS RETAINING WALLS, ELECTRICAL EQUIPMENT PLATFORMS, SLIDING GATE, ETC. PRIOR TO ALL MATERIAL ORDERING AND FABRICATION. THE SURVEY SHALL BE SUBMITTED TO THE ENGINEER OF RECORD FOR REVIEW.

FOUNDATIONS:

1. FOUNDATION DESIGN IS BASED UPON THE GEOTECHNICAL INVESTIGATION AND REPORT PROVIDED BY YU & ASSOCIATES DATED OCTOBER 18, 2019.
2. THE FOUNDATION CONTRACTOR SHALL VERIFY ALL FIELD CONDITIONS BEFORE EXCAVATION HAS BEGUN. CONTRACTOR SHALL SUBMIT FIELD SKETCHES TO ENGINEERS FOR REVIEW AND APPROVAL WHERE CONDITION DEVIATES FROM CONTRACT DOCUMENTS.
3. BOTTOM 3" OF EXCAVATION FOR FOOTINGS AND GRADE BEAMS SHALL BE FINISHED BY HAND SHOVEL OR AS DIRECTED BY TESTING AGENCIES AND INSPECTED AND CERTIFIED BY PROFESSIONAL AND /OR GEOTECHNICAL ENGINEERS.
4. FOUNDATIONS SHALL BEAR ON SOIL WITH A MINIMUM ALLOWABLE BEARING PRESSURE OF 2 TONS PER SQUARE FOOT AND PILES SHALL HAVE AN AXIAL CAPACITY OF 20T AND A LATERAL CAPACITY OF 3T. REFER TO YU & ASSOCIATES GEOTECHNICAL REPORT FOR FURTHER INFORMATION.
5. THE SOIL BEARING CAPACITY MUST BE VERIFIED BY THE CONTRACTOR AND SPECIAL INSPECTOR. IF PROBLEMS ARE ENCOUNTERED, IMMEDIATELY NOTIFY THE PROJECT GEOTECHNICAL ENGINEER. IF ADEQUATE SOIL IS NOT FOUND AT THE DEPTH SHOWN ON THESE DRAWINGS, THE FOOTING SHALL REMAIN AT ITS SPECIFIED BEARING ELEVATION AND THE UNDERLYING UNSUITABLE MATERIAL SHALL BE REMOVED AND REPLACED WITH COMPACTED GRAVEL FILL OR CONCRETE (f_c = 3,500 PSI). SUBGRADE FOR ALL FOOTINGS SHALL BE SUBJECT TO SPECIAL INSPECTION PRIOR TO PLACEMENT OF CONCRETE.
6. CONTRACTOR SHALL NOT UNDERMINE EXISTING FOOTINGS OR SLABS.
7. PROVIDE TEMPORARY SUPPORTS AS REQUIRED, SO THAT NO HORIZONTAL MOVEMENT OR VERTICAL SETTLEMENT OCCURS TO EXISTING STRUCTURES AT THE PROJECT SITE.
8. DEWATERING OF THE SITE DURING CONSTRUCTION IS SOLELY THE RESPONSIBILITY OF THE CONTRACTOR.
9. BACKFILL UNDER AND ADJACENT TO ANY PORTION OF THE STRUCTURE SHALL BE COMPACTED TO 98% OF THE MAXIMUM DRY DENSITY PER ASTM D-698 IN 6" LIFTS.

CONCRETE:

1. ALL CONCRETE WORK SHALL COMPLY WITH THE AMERICAN CONCRETE INSTITUTE ("ACI") "BUILDING CODE REQUIREMENTS FOR REINFORCED CONCRETE" ACI 318-11 AND "SPECIFICATIONS FOR STRUCTURAL CONCRETE FOR BUILDINGS" ACI 301-05.
2. CONCRETE MIXES SHALL BE PREPARED IN ACCORDANCE WITH THE NYC BUILDING CODE REQUIREMENTS AND SUBMITTED FOR REVIEW AT LEAST 14 DAYS PRIOR TO THE PLACEMENT OF CONCRETE.
3. ALL CONCRETE SHALL BE NORMAL WEIGHT WITH A MINIMUM 28-DAY COMPRESSIVE STRENGTH OF 5,000 PSI AND A MAXIMUM WATER/CEMENT RATIO OF 0.40 BY WEIGHT.
4. ALL CONCRETE SHALL BE AIR ENTRAINED PER ASTM C231 AND SHALL BE SELF-CONSOLIDATING WITH A MAXIMUM SHRINKAGE OF 0.02%.
5. ALL REINFORCING STEEL SHALL BE GALVANIZED CONFORMING TO ASTM A767 CLASS I.
6. ALL STEEL SHALL BE SECURELY HELD IN PLACE DURING POURING OF CONCRETE. IF REQUIRED, CHAIRS, REBARS, TIES, SPACERS OR ADDITIONAL BARS AND STIRRUPS SHALL BE PROVIDED BY THE GENERAL CONTRACTOR TO FURNISH SUPPORT FOR ALL BARS.
7. LOCATION OF ALL CONSTRUCTION JOINTS SHALL BE SUBMITTED TO THE STRUCTURAL ENGINEER FOR APPROVAL PRIOR TO DETAILING OF REINFORCEMENT. THE STRUCTURAL ENGINEER MAY REQUIRE ADDITIONAL REINFORCING AT SUCH JOINTS.
8. CHAMFER ALL EXPOSED CONCRETE 3/4" UNLESS OTHERWISE NOTED.

CONCRETE CONTINUED:

CONCRETE COVER			
ELEMENT	BOTTOM	TOP	SIDE
GRADE BEAMS	3"	2"	2**
STRIP FOOTINGS	3"	2"	2**
PIERS/WALLS	1-1/2" (STIRRUPS)	2"	1-1/2"

*COVER IS 2" WHERE CONCRETE IS FORMED AND 3" WHERE POURED AGAINST EARTH

ALL STEEL REINFORCING BAR DEVELOPMENT LENGTHS, UNLESS INDICATED OTHERWISE, SHALL SATISFY THE FOLLOWING:

WALLS			BAR SIZE	GRADE BEAMS PIERS FOOTINGS
BAR SIZE	VERTICAL BARS	HORIZONTAL BARS		
#3	13	17	#3	17
#4	17	23	#4	23
#5	22	28	#5	28
#6	26	34	#6	34
#7	38	49	#7	73
#8	43	56	#8	83
#9	48	63	#9	94
#10	54	71	#10	106
#11	60	78	#11	117

TABLE NOTES:

1. TABLE ABOVE LISTS VALUES OF "Ld" IN INCHES.
2. ALL LAP SPLICES SHALL BE 1.3 Ld UNLESS NOTED OTHERWISE ON THE DRAWINGS.

STRUCTURAL STEEL:

1. ALL WORK SHALL CONFORM TO THE AMERICAN INSTITUTE OF STEEL CONSTRUCTION "SPECIFICATION FOR STRUCTURAL STEEL BUILDINGS-ALLOWABLE STRESS DESIGN AND LOAD RESISTANCE FACTOR DESIGN", AISC 360-05, AS MODIFIED BY CHAPTER 22 OF THE NYC BUILDING CODE 2014.
2. ALL WORK SHALL CONFORM TO THE AMERICAN INSTITUTE OF STEEL CONSTRUCTION "CODE OF STANDARD PRACTICE" AISC 303-05.
3. ALL PLATES, CHANNELS, ANGLES AND MISCELLANEOUS PIECES SHALL BE ASTM A572 GRADE 50. STRUCTURAL STEEL TUBING SHALL BE ASTM A500, GRADE C.
4. ALL STEEL, CONNECTIONS, AND CONNECTION COMPONENTS ARE TO BE GALVANIZED PER ASTM A123, A385, AND A653 AS APPLICABLE. ALL STEEL, CONNECTIONS, AND CONNECTION COMPONENTS WITH GALVANIC COATING DAMAGED DURING THE COMPLETION OF THIS PROJECT ARE TO BE REPAIRED PER ASTM A780.
5. SHOP DRAWINGS, PREPARED IN ACCORDANCE WITH AISC "DETAILING FOR STEEL CONSTRUCTION", SHALL BE SUBMITTED TO THE ENGINEER FOR REVIEW AND ACCEPTED PRIOR TO PERFORMING WORK.
6. OBTAIN ALL FIELD MEASUREMENTS REQUIRED FOR PROPER FABRICATION AND INSTALLATION PRIOR TO THE START OF DETAILING AND FABRICATION. PRECISE MEASUREMENTS ARE THE SOLE RESPONSIBILITY OF THE CONTRACTOR.
7. BOLTS SHALL BE 3/4 INCHES IN DIAMETER MINIMUM, UNLESS OTHERWISE NOTED. BOLTS, NUTS AND WASHERS SHALL CONFORM TO THE REQUIREMENTS OF ASTM A325 OR A490. PROVIDE A MINIMUM OF 2 BOLTS PER CONNECTION.
8. ALL WELDING ELECTRODES SHALL BE E70XX. MINIMUM FILLET WELD SIZES SHALL COMPLY WITH THE AISC SPECIFICATION, BUT SHALL NOT BE LESS THAN 1/4 INCH, UNLESS OTHERWISE NOTED. IN THESE DRAWINGS.
9. ALL WELDING SHALL BE DONE BY NEW YORK CITY CERTIFIED WELDERS AND SHALL CONFORM TO THE AMERICAN WELDING SOCIETY AWS D1.1.
10. ALL PIPES AND TUBES SHALL BE COMPLETELY SEALED WITH CAP PLATES.
11. LOCATION AND TYPE OF SPLICE SHALL BE SPECIFICALLY DETAILED ON SHOP DRAWINGS. SPLICING OF STRUCTURAL STEEL MEMBERS ARE PROHIBITED WITHOUT PRIOR APPROVAL FROM THE ENGINEER.
12. FIELD CUTTING OF STEEL IS NOT PERMITTED UNLESS APPROVED BY THE ENGINEER.
13. SEE LANDSCAPE ARCHITECTURE DRAWING AND SPECIFICATIONS FOR ALL STEEL PAINTING.

STV 100 Years
 STV INCORPORATED
 225 PARK AVENUE SOUTH
 5TH FLOOR
 NEW YORK, NY 10003
 www.stvinc.com

CONSULTANTS

SITWORKS
 LANDSCAPE ARCHITECTURE, LLC
 150 WEST 28TH STREET
 SUITE 605
 NEW YORK, NY 10001
 www.sitworkscom.com

SEALS

PROJECT IDENTIFICATION

NEW YORK STATE OF OPPORTUNITY
Battery Park City Authority
 BATTERY PARK CITY
 BALLFIELD AND COMMUNITY CENTER

MARK	DATE	DESCRIPTION	BY
C	11/01/19	ISSUED FOR BID- 95%	AC
B	10/18/19	75% DESIGN SUBMITTAL	AC
A	09/06/19	50% DESIGN SUBMITTAL	AC

ISSUE BLOCK

PROJECT NO.:	3019666
DESIGNED BY:	N. TOLLI
DRAWN BY:	N. TOLLI
CHECKED BY:	A. CERINO P.E.
APPROVED BY:	A. CERINO P.E.
COPYRIGHT:	STV, INC

SHEET TITLE

**STRUCTURAL
 NOTES SHEET
 1 OF 3**

S-001

POST-INSTALLED ANCHORS:

- EXCEPT WHERE INDICATED ON THE DRAWINGS, POST-INSTALLED ANCHORS SHALL CONSIST OF THE FOLLOWING ANCHOR TYPES AS PROVIDED BY HILTI, INC. OR APPROVED EQUAL AND INSTALLED IN ACCORDANCE WITH THEIR RESPECTIVE ICC-ES REPORT AND MANUFACTURER'S PUBLISHED INSTALLATION INSTRUCTIONS:

APPLICATION	ANCHORING SYSTEM	ICC-ES REPORT
ANCHORAGE TO CONCRETE	HILTI HIT-HY 200 ADHESIVE	ESR-3187
	HILTI KWIK BOLT TZ	ESR-1917
	HILTI KWIK HUS EZ	ESR-3027
REBAR DOWELING	HILTI RE 500 V3 ADHESIVE	ESR-3814
	HILTI HIT-HY 200 ADHESIVE	ESR-3187

- CONTRACTOR SHALL ARRANGE AN ANCHOR MANUFACTURER'S REPRESENTATIVE TO PROVIDE ON-SITE ANCHOR INSTALLATION TRAINING FOR ALL OF THEIR ANCHOR PRODUCTS SPECIFIED. CONTRACTOR SHALL SUBMIT DOCUMENTED CONFIRMATION THAT ALL OF THE CONTRACTOR'S PERSONNEL INSTALLING ANCHORS HAVE RECEIVED THE REQUIRED TRAINING PRIOR TO THE COMMENCEMENT OF WORK.
- ANCHOR CAPACITY IS DEPENDENT UPON SPACING BETWEEN ANCHORS AND PROXIMITY OF ANCHORS TO EDGE OF BASE MATERIAL. INSTALL ANCHORS IN ACCORDANCE WITH SPACING AND EDGE CLEARANCES INDICATED ON THE DRAWINGS OR PER THE MANUFACTURER'S GUIDELINES.
- CONTINUOUS OR PERIODIC SPECIAL INSPECTION FOR POST-INSTALLED ANCHORS SHALL BE PERFORMED IN ACCORDANCE WITH SECTION 4.3/4.4 OF THE ICC-ES REPORT FOR THE INDIVIDUAL ANCHOR. SPECIAL INSPECTOR SHALL BE NOTIFIED PRIOR TO COMMENCEMENT OF WORK TO COORDINATE INSPECTION EFFORTS.
- EXISTING REINFORCING BARS IN THE CONCRETE STRUCTURE MAY CONFLICT WITH SPECIFIC ANCHOR LOCATIONS. UNLESS NOTED IN THE DRAWINGS THAT THE BARS CAN BE CUT, THE CONTRACTOR SHALL REVIEW THE EXISTING STRUCTURAL DRAWINGS AND SHALL UNDERTAKE TO LOCATE THE POSITION OF THE REINFORCING BARS AT THE LOCATIONS OF THE CONCRETE ANCHORS BY GPR, X-RAY OR OTHER NON-DESTRUCTIVE TESTING MEANS. MODIFICATION OF FINAL ANCHOR LOCATIONS AND ATTACHING ELEMENTS MAY BE REQUIRED BASED ON FIELD-VERIFIED CONDITIONS.
- CONTRACTOR SHALL SUBMIT TECHNICAL PRODUCT DATA WITH RECOMMENDED DESIGN VALUES, SAMPLES, QUALITY ASSURANCE TESTING REPORTS, CERTIFICATES AND INSTALLATION PROCEDURES FOR REVIEW BY THE ENGINEER OF RECORD.
- PROVIDE GALVANIC SEPARATION WHEN ANCHORS ARE IN CONTACT WITH DISSIMILAR METALS.

REQUIRED SPECIAL INSPECTIONS AND OTHER:

- OWNER SHALL PAY FOR THE SERVICES OF A SPECIAL INSPECTION AGENCY LICENSED TO PROVIDE SERVICES IN ACCORDANCE WITH THE NYC BUILDING CODE FOR THE FOLLOWING STRUCTURAL ITEMS:
 - 1704.3 STEEL CONSTRUCTION
 - 1704.4 CONCRETE CONSTRUCTION
 - 1704.7 SUBSURFACE CONDITIONS
 - 1704.20 STRUCTURAL STABILITY
 - 1704.32 POST INSTALLED ANCHORS
 - G105.2 FLOOD ZONE COMPLIANCE SPECIAL INSPECTION
 - G105.4 FLOOD SHIELD INSPECTION
- ENGINEER SHALL INSPECT ALL CONSTRUCTION BEFORE AND AFTER PLACEMENT OF CONCRETE TO ENSURE NO VOIDS AT MATERIAL INTERFACES. PROVIDE ENGINEER WITH 48-HOUR PRIOR NOTIFICATION OF CONCRETE POURS TO ENSURE INSPECTIONS HAPPEN WITH NO PROJECT DELAY. THIS REVIEW IS IN ADDITION TO THE CODE REQUIRED SPECIAL INSPECTIONS LISTED ABOVE.

ABBREVIATIONS

ALUM.	ALUMINUM	LF	LINEAR FOOT/FEET
APPROX.	APPROXIMATE	MAX	MAXIMUM
BLDG	BUILDING	MECH	MECHANICAL
B.O.	BOTTOM OF	MIN	MINIMUM
CL	CENTERLINE	NIC	NOT IN CONTRACT
CMU	CONCRETE MASONRY UNIT	NTS	NOT TO SCALE
CONC	CONCRETE	OC	ON CENTER
CONT	CONTINUOUS	PCF	POUNDS PER CUBIC FOOT
DFE	DESIGN FLOOD ELEVATION	PSF	POUNDS PER SQUARE FOOT
DIA	DIAMETER	SF	SQUARE FOOT/FEET
DN	DOWN	T.O., T/	TOP OF
EL, ELEV.	ELEVATION	T.O.S.	TOP OF SLAB
ELEC	ELECTRICAL	T.O.W.	TOP OF WALL
E.W.	EACH WAY	TYP	TYPICAL
EXIST	EXISTING	U.O.N.	UNLESS OTHERWISE NOTED
EXT	EXTERIOR	VERT	VERTICAL
FT.	FOOT/FEET	W/C	WATER TO CEMENT RATIO
GA	GAUGE		
GALV	GALVANIZED		
HORIZ.	HORIZONTAL		
IN.	INCH(ES)		
INT	INTERIOR		
INV	INVERT		
KSI	KIPS PER SQUARE INCH		



STV INCORPORATED
225 PARK AVENUE SOUTH
5TH FLOOR
NEW YORK, NY 10003
www.stvinc.com

CONSULTANTS



150 WEST 28TH STREET
SUITE 605
NEW YORK, NY 10001
www.sitworkscm.com

SEALS

PROJECT IDENTIFICATION



BATTERY PARK CITY
BALLFIELD AND COMMUNITY
CENTER

MARK	DATE	DESCRIPTION	BY
C	11/01/19	ISSUED FOR BID- 95%	AC
B	10/18/19	75% DESIGN SUBMITTAL	AC
A	09/06/19	50% DESIGN SUBMITTAL	AC

ISSUE BLOCK

PROJECT NO.: 3019666
DESIGNED BY: N. TOLLI
DRAWN BY: N. TOLLI
CHECKED BY: A. CERINO P.E.
APPROVED BY: A. CERINO P.E.
COPYRIGHT: STV, INC

SHEET TITLE

STRUCTURAL
NOTES SHEET
2 OF 3

S-002

MARK	DATE	DESCRIPTION	BY
C	11/01/19	ISSUED FOR BID- 95%	AC
B	10/18/19	75% DESIGN SUBMITTAL	AC
A	09/06/19	50% DESIGN SUBMITTAL	AC

ISSUE BLOCK

PROJECT NO.:	3019666
DESIGNED BY:	N. TOLLI
DRAWN BY:	N. TOLLI
CHECKED BY:	A. CERINO P.E.
APPROVED BY:	A. CERINO P.E.
COPYRIGHT:	STV, INC

SHEET TITLE

**STRUCTURAL
NOTES SHEET
3 OF 3**

S-003

FLOOD LOADING:

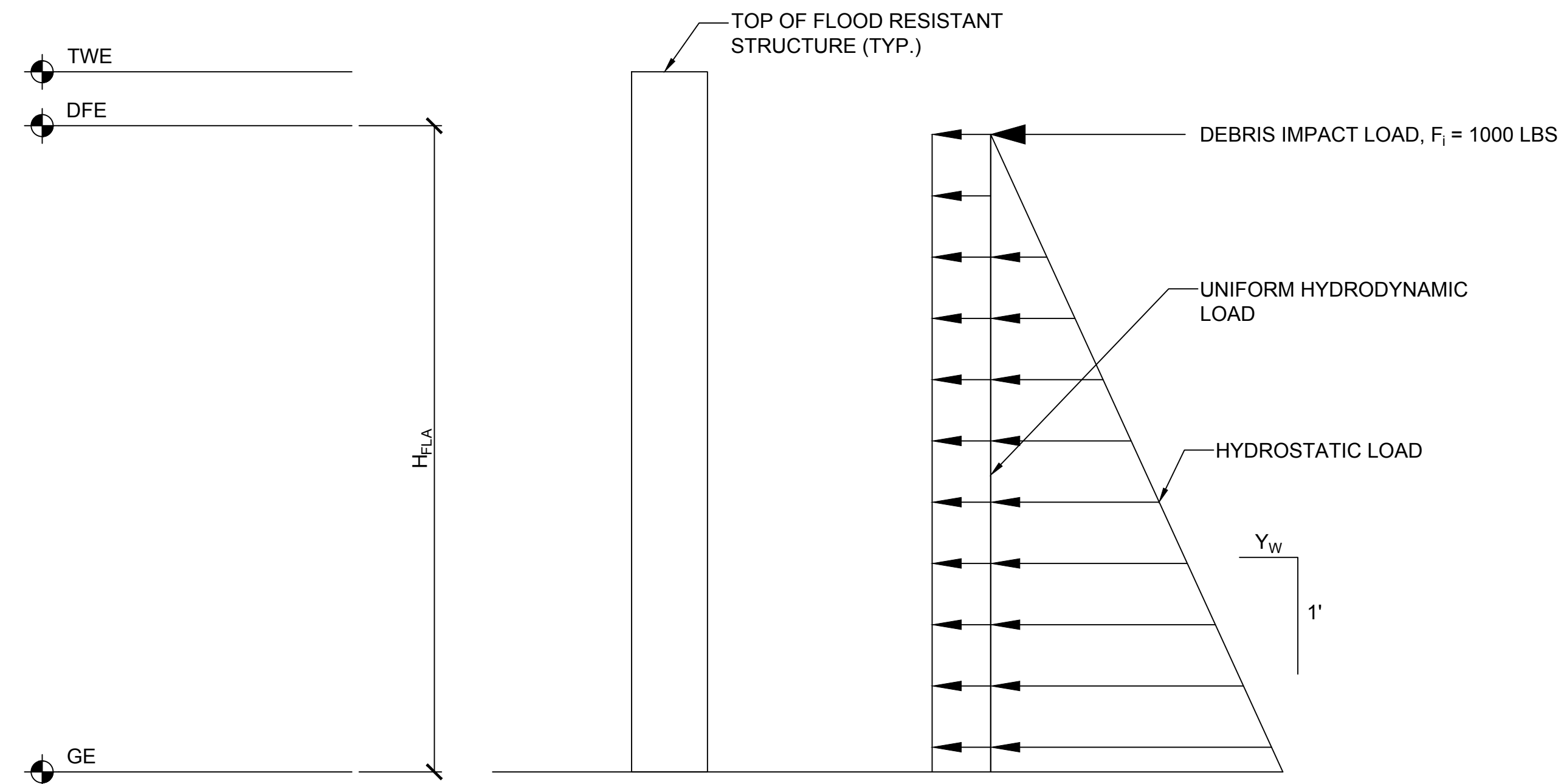

CASE 1 FLOOD LOAD DIAGRAM
APPLICABLE AT ALL BUILDING PERIMETERS

LEGEND

- TWE TOP OF WALL ELEVATION
- DFE DESIGN FLOOD ELEVATION = EL. 12.0' (NAVD88)
- GE GROUND ELEVATION
- d_h EQUIVALENT SURCHARGE DEPTH OF WATER
 $d_h = av^2/2g$ WHERE: $a = 1.25$
 $v = \text{VARIES (SEE NOTE 3)}$
 $g = 32.2 \text{ FT/SEC}^2$
- Y_w UNIT WEIGHT OF SEA WATER
- F_i DEBRIS IMPACT LOAD
- H_{FLA} HEIGHT OF FLOODWATER ABOVE GRADE (DFE-GE)

NOTES:

1. THE DESIGN FLOOD LOAD IS CALCULATED IN ACCORDANCE WITH ASCE 7-10, CHAPTER 5 WITH A DESIGN FLOOD ELEVATION REFERENCING NAVD88 DATUM.
2. PER ASCE 7 GUIDELINES, HYDRODYNAMIC PRESSURE IS CONVERTED TO AN EQUIVALENT HYDROSTATIC LOAD FOR ANALYSIS AND DESIGN PURPOSES.
3. AVERAGE VELOCITY COMPUTED PER EQUATIONS C5-1 AND C5-2 IN ASCE 7-10.

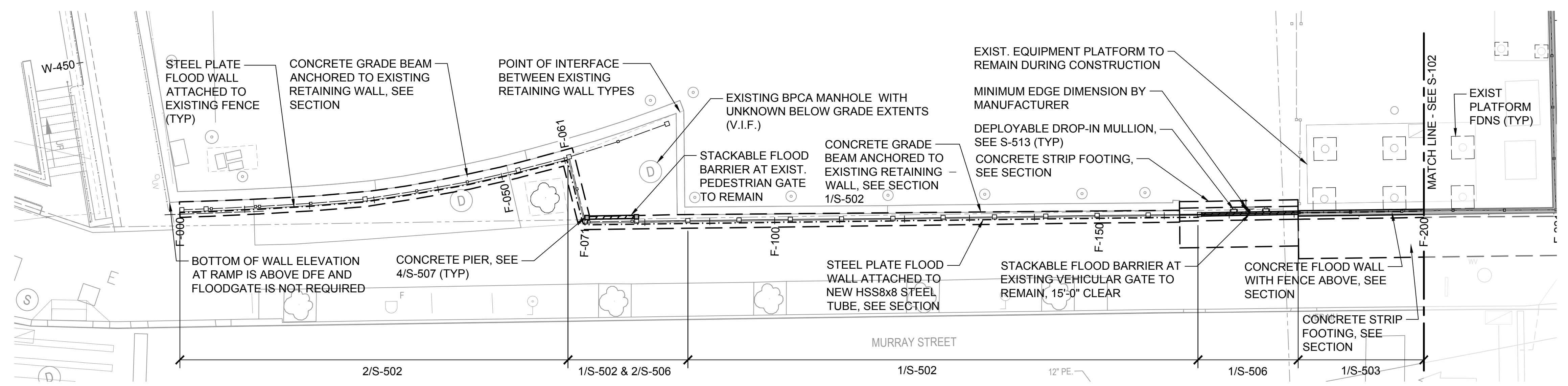

1 FENCE RING WALL PLAN - AREA 1
 S-101 1"=10'

- NOTES:
1. TOP OF CONCRETE GRADE BEAM IS TO BE LOCATED 3" ABOVE TOP OF GRADE AS SHOWN ON THE CIVIL DRAWINGS UNLESS OTHERWISE NOTED.
 2. REFER TO 1/S-501 FOR REQUIRED DETAILING AT CONDITIONS WHERE TOP OF CONCRETE FALLS LESS THAN 4" ABOVE TOP OF FENCE POST BASE PLATE.
 3. PROJECT INTENT IS FOR THE EXISTING PEDESTRIAN AND VEHICULAR GATE TO REMAIN IF POSSIBLE. THE GATES MAY BE REMOVED, STORED, AND REPLACED AT CONTRACTOR'S OPTION DURING CONSTRUCTION.

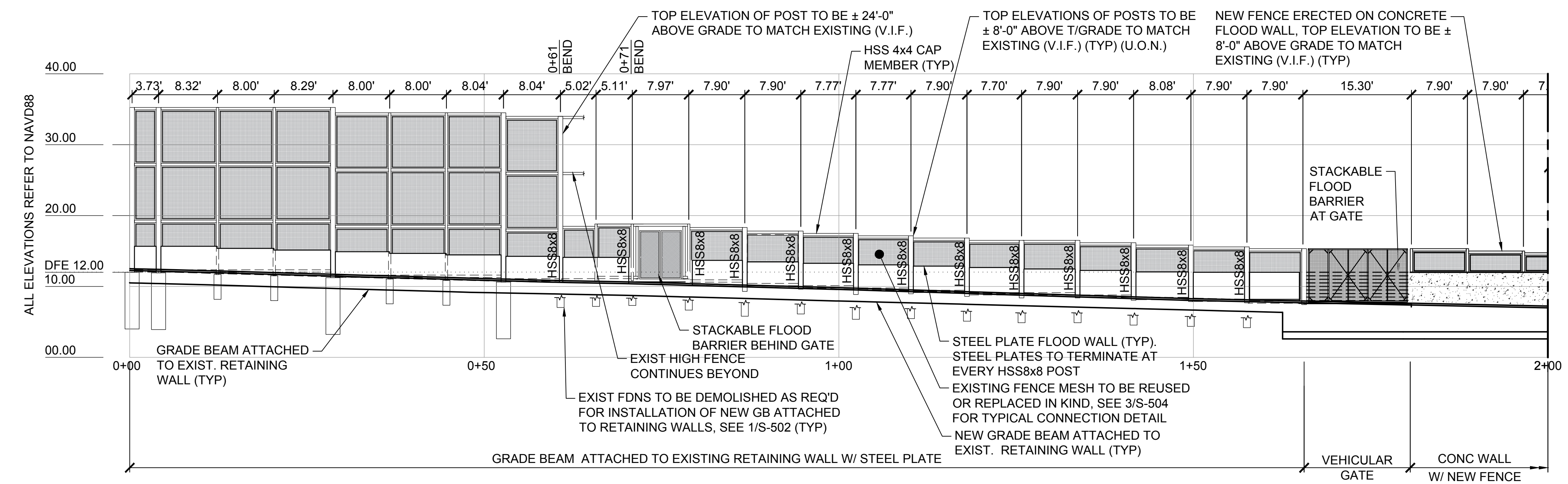

A ELEVATION
 S-101 1"=10'

- NOTES:
1. AT NEW FENCE CONSTRUCTION LOCATIONS, TOP OF STEEL POSTS AND HORIZONTAL MEMBERS SHALL MATCH EXISTING (V.I.F.)
 2. CHANGES IN GEOMETRY OF THE EXISTING FENCE ALIGNMENT ARE DENOTED BY THEIR CORRESPONDING BASELINE STATION AND "BEND", SEE PLAN.
 3. ALL TOP OF STEEL PLATE ELEVATIONS MUST BE AT A MINIMUM OF THE DESIGN FLOOD ELEVATION (EL. +12.0' NAVD88). ALL STEEL PLATE HEIGHTS SHALL MATCH DECORATIVE PANEL HEIGHTS SHOWN ON LANDSCAPE ARCHITECT DRAWINGS INSOFAR AS THE PANEL TOP ELEVATIONS ARE EQUAL TO OR ABOVE THE DESIGN FLOOD ELEVATION.

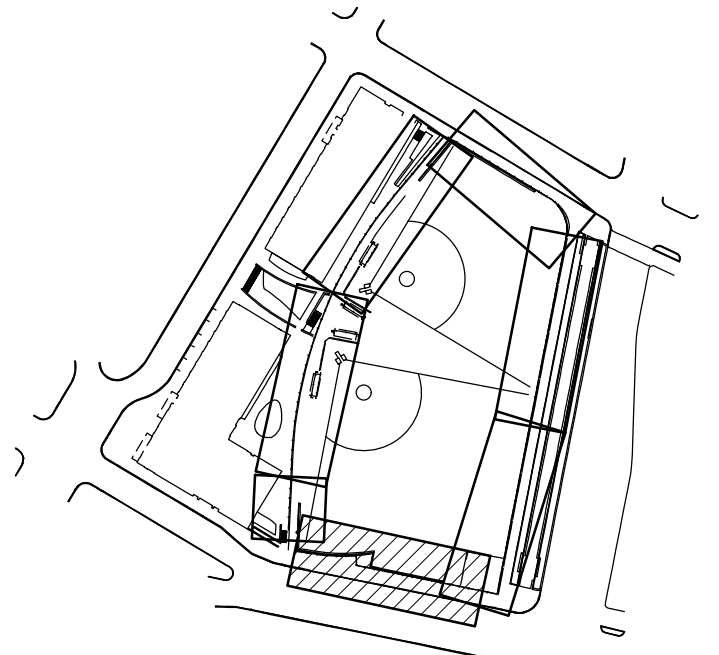

KEY PLAN
 NOT TO SCALE

SEALS

PROJECT IDENTIFICATION

NEW YORK STATE OF OPPORTUNITY
Battery Park City Authority
 BATTERY PARK CITY
 BALLFIELD AND COMMUNITY CENTER

MARK	DATE	DESCRIPTION	BY
C	11/01/19	ISSUED FOR BID- 95%	AC
B	10/18/19	75% DESIGN SUBMITTAL	AC
A	09/06/19	50% DESIGN SUBMITTAL	AC

ISSUE BLOCK

PROJECT NO.:	3019666
DESIGNED BY:	N. TOLLI
DRAWN BY:	T. WISE
CHECKED BY:	A. CERINO P.E.
APPROVED BY:	A. CERINO P.E.
COPYRIGHT:	STV, INC

SHEET TITLE

**PERIMETER
 PLAN SHEET
 1 OF 4**

S-101

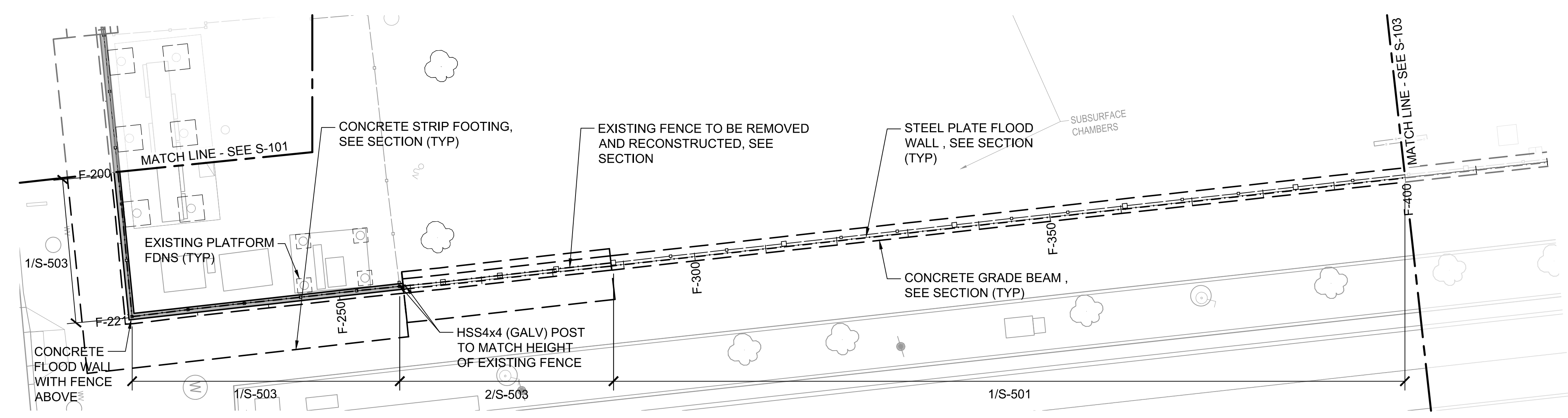

1 FENCE RING WALL PLAN - AREA 2
 S-102 1"=10'

- NOTES:
1. TOP OF CONCRETE GRADE BEAM IS TO BE LOCATED 3" ABOVE TOP OF GRADE AS SHOWN ON THE CIVIL DRAWINGS UNLESS OTHERWISE NOTED.
 2. REFER TO 1/S-501 FOR REQUIRED DETAILING AT CONDITIONS WHERE TOP OF CONCRETE FALLS LESS THAN 4" ABOVE TOP OF FENCE POST BASE PLATE.

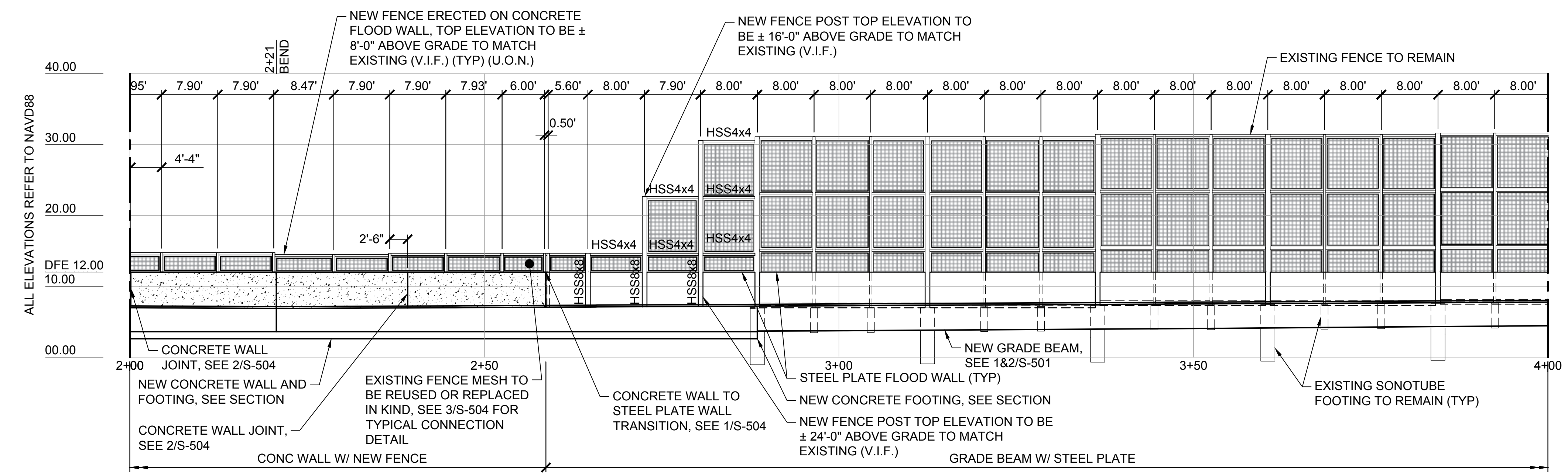

A ELEVATION
 S-102 1"=10'

- NOTES:
1. AT NEW FENCE CONSTRUCTION LOCATIONS, TOP OF STEEL POSTS AND HORIZONTAL MEMBERS SHALL MATCH EXISTING (V.I.F.)
 2. CHANGES IN GEOMETRY OF THE EXISTING FENCE ALIGNMENT ARE DENOTED BY THEIR CORRESPONDING BASELINE STATION AND "BEND", SEE PLAN.
 3. ALL TOP OF STEEL PLATE ELEVATIONS MUST BE AT A MINIMUM OF THE DESIGN FLOOD ELEVATION (EL. +12.0' NAVD88). ALL STEEL PLATE HEIGHTS SHALL MATCH DECORATIVE PANEL HEIGHTS SHOWN ON LANDSCAPE ARCHITECT DRAWINGS INSOFAR AS THE PANEL TOP ELEVATIONS ARE EQUAL TO OR ABOVE THE DESIGN FLOOD ELEVATION.

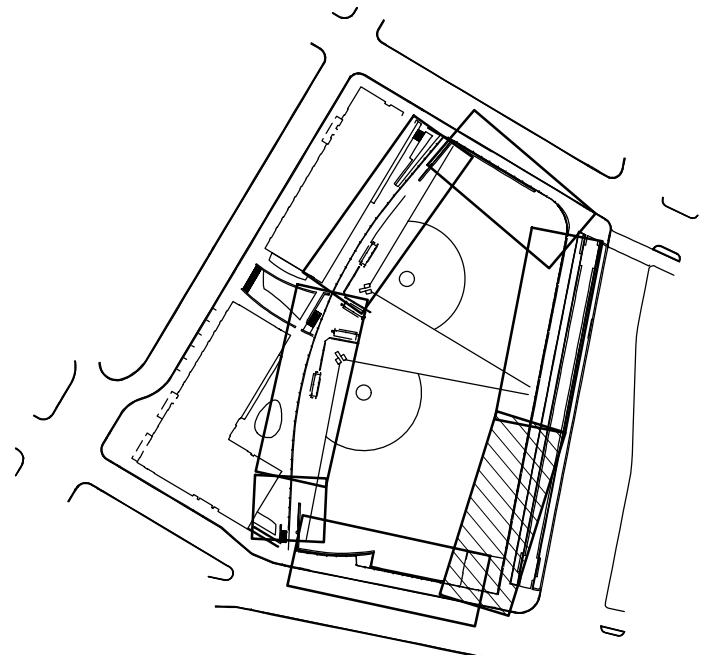

KEY PLAN
 NOT TO SCALE

SEALS

PROJECT IDENTIFICATION
 NEW YORK STATE OF OPPORTUNITY
Battery Park City Authority
 BATTERY PARK CITY
 BALLFIELD AND COMMUNITY CENTER

MARK	DATE	DESCRIPTION	BY
C	11/01/19	ISSUED FOR BID- 95%	AC
B	10/18/19	75% DESIGN SUBMITTAL	AC
A	09/06/19	50% DESIGN SUBMITTAL	AC

ISSUE BLOCK

PROJECT NO.:	3019666
DESIGNED BY:	N. TOLLI
DRAWN BY:	T. WISE
CHECKED BY:	A. CERINO P.E.
APPROVED BY:	A. CERINO P.E.
COPYRIGHT:	STV, INC

SHEET TITLE
PERIMETER PLAN SHEET
 2 OF 4

S-102

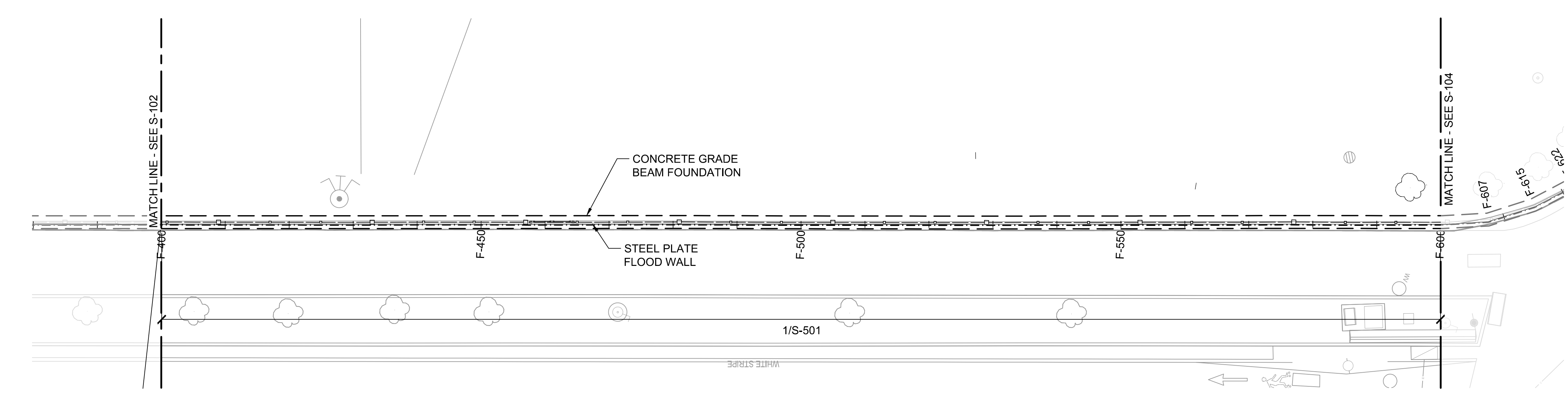

1 FENCE RING WALL PLAN - AREA 3
 S-103 1"=10'

- NOTES:
 1. TOP OF CONCRETE GRADE BEAM IS TO BE LOCATED 3" ABOVE TOP OF GRADE AS SHOWN ON THE CIVIL DRAWINGS UNLESS OTHERWISE NOTED.
 2. REFER TO 1/S-501 FOR REQUIRED DETAILING AT CONDITIONS WHERE TOP OF CONCRETE FALLS LESS THAN 4" ABOVE TOP OF FENCE POST BASE PLATE.

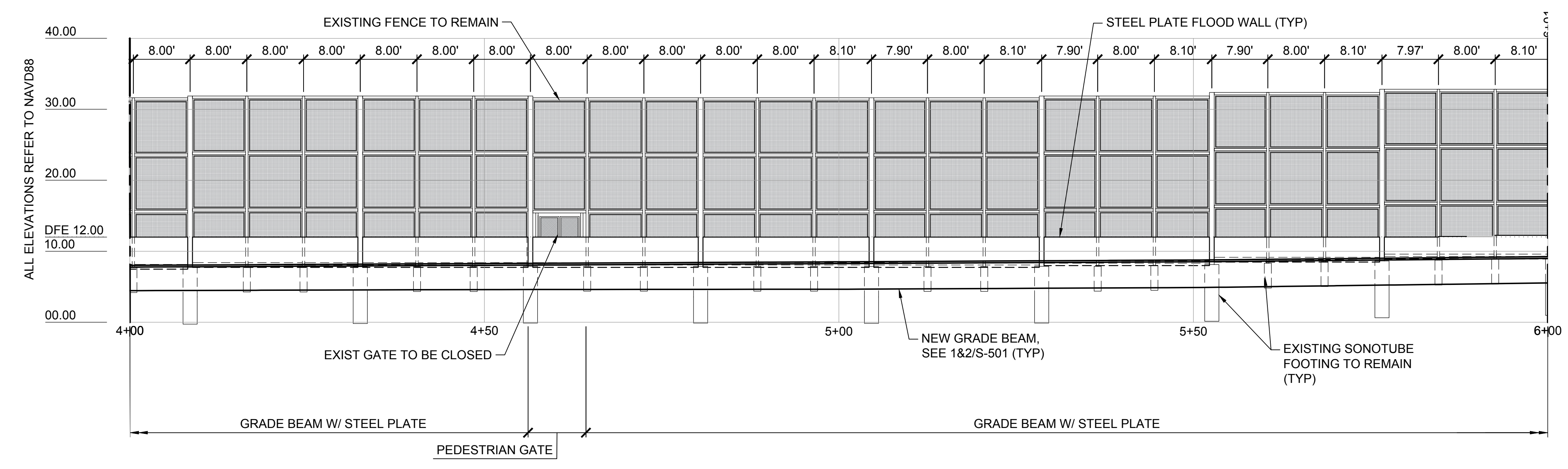

A ELEVATION
 S-103 1"=10'

- NOTES:
 1. AT NEW FENCE CONSTRUCTION LOCATIONS, TOP OF STEEL POSTS AND HORIZONTAL MEMBERS SHALL MATCH EXISTING (V.I.F.)
 2. CHANGES IN GEOMETRY OF THE EXISTING FENCE ALIGNMENT ARE DENOTED BY THEIR CORRESPONDING BASELINE STATION AND "BEND", SEE PLAN.
 3. ALL TOP OF STEEL PLATE ELEVATIONS MUST BE AT A MINIMUM OF THE DESIGN FLOOD ELEVATION (EL. +12.0' NAVD88). ALL STEEL PLATE HEIGHTS SHALL MATCH DECORATIVE PANEL HEIGHTS SHOWN ON LANDSCAPE ARCHITECT DRAWINGS INSOFAR AS THE PANEL TOP ELEVATIONS ARE EQUAL TO OR ABOVE THE DESIGN FLOOD ELEVATION.

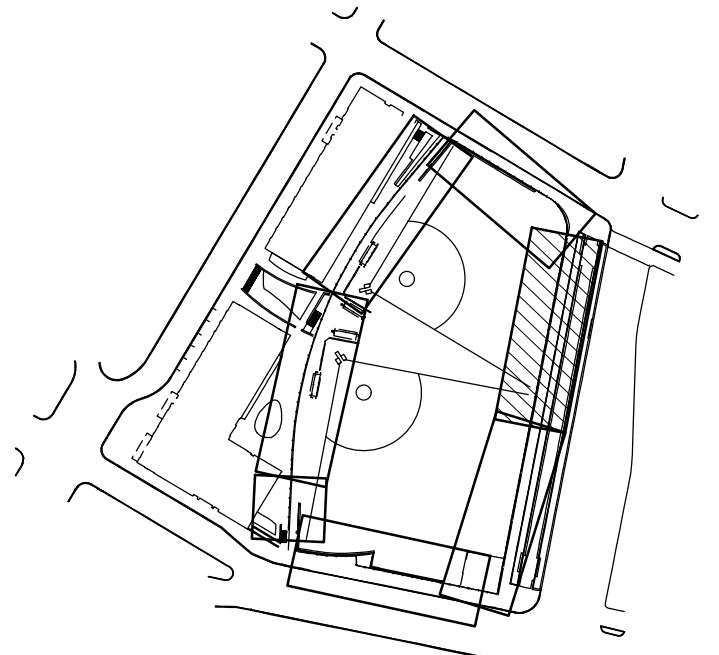

KEY PLAN
 NOT TO SCALE

SEALS

PROJECT IDENTIFICATION
 NEW YORK STATE OF OPPORTUNITY
Battery Park City Authority
 BATTERY PARK CITY
 BALLFIELD AND COMMUNITY CENTER

MARK	DATE	DESCRIPTION	BY
C	11/01/19	ISSUED FOR BID- 95%	AC
B	10/18/19	75% DESIGN SUBMITTAL	AC
A	09/06/19	50% DESIGN SUBMITTAL	AC

ISSUE BLOCK

PROJECT NO.:	3019666
DESIGNED BY:	N. TOLLI
DRAWN BY:	T. WISE
CHECKED BY:	A. CERINO P.E.
APPROVED BY:	A. CERINO P.E.
COPYRIGHT:	STV, INC

SHEET TITLE
PERIMETER PLAN SHEET
 3 OF 4

S-103

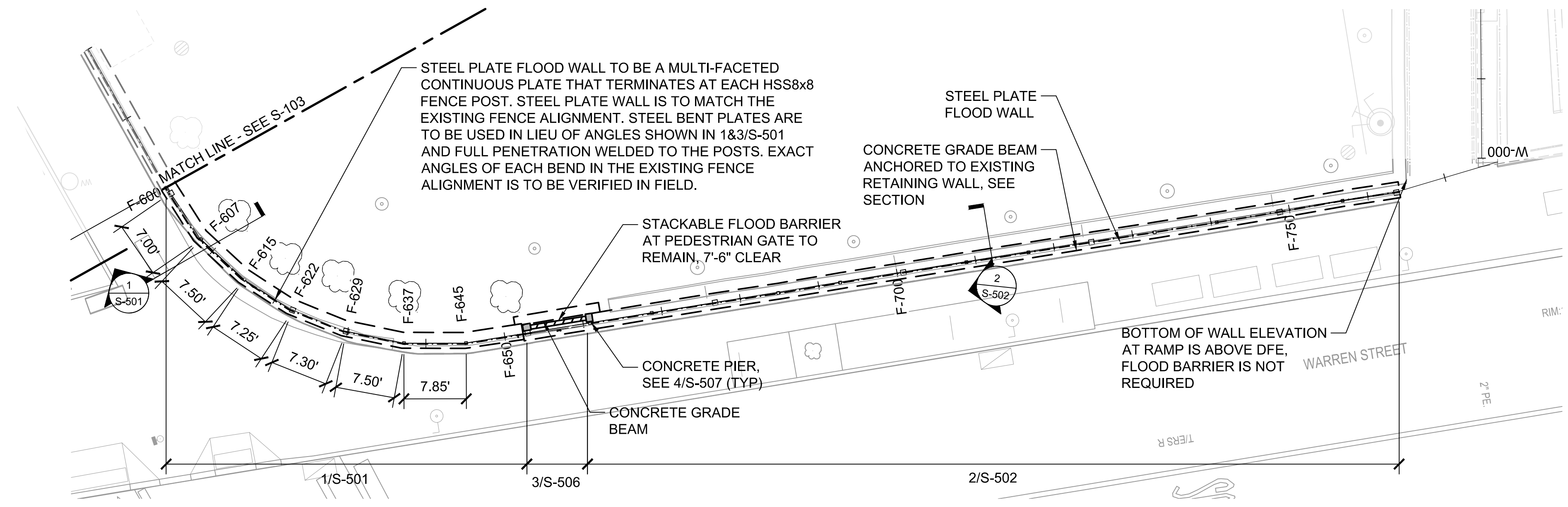

1 FENCE RING WALL PLAN - AREA 4
 S-104 1"=10' 10' 5' 0' 10'

- NOTES:
1. TOP OF CONCRETE GRADE BEAM IS TO BE LOCATED 3" ABOVE TOP OF GRADE AS SHOWN ON THE CIVIL DRAWINGS UNLESS OTHERWISE NOTED.
 2. REFER TO 1/S-501 FOR REQUIRED DETAILING AT CONDITIONS WHERE TOP OF CONCRETE FALLS LESS THAN 4" ABOVE TOP OF FENCE BASE PLATE.
 3. PROJECT INTENT IS FOR THE EXISTING PEDESTRIAN GATE TO REMAIN IF POSSIBLE. THE GATE MAY BE REMOVED, STORED, AND REPLACED AT CONTRACTOR'S OPTION DURING CONSTRUCTION.

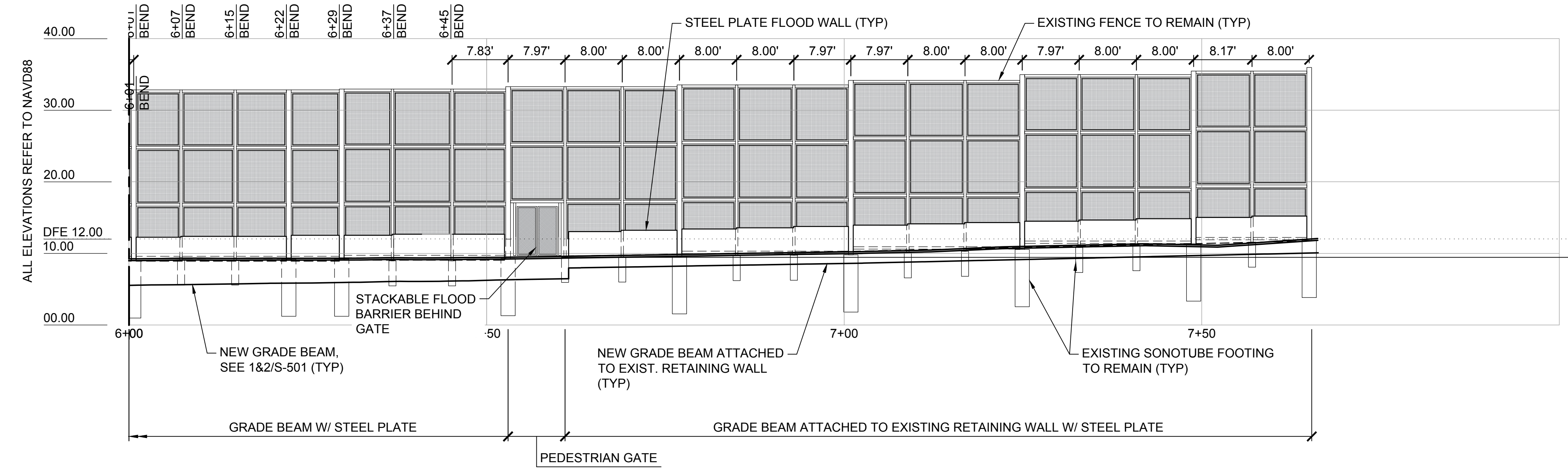

A ELEVATION
 S-104 1"=10' 10' 5' 0' 10'

- NOTES:
1. AT NEW FENCE CONSTRUCTION LOCATIONS, TOP OF STEEL POSTS AND HORIZONTAL MEMBERS SHALL MATCH EXISTING (V.I.F.)
 2. CHANGES IN GEOMETRY OF THE EXISTING FENCE ALIGNMENT ARE DENOTED BY THEIR CORRESPONDING BASELINE STATION AND "BEND". SEE PLAN.
 3. ALL TOP OF STEEL PLATE ELEVATIONS MUST BE AT A MINIMUM OF THE DESIGN FLOOD ELEVATION (EL. +12.0' NAVD88). ALL STEEL PLATE HEIGHTS SHALL MATCH DECORATIVE PANEL HEIGHTS SHOWN ON LANDSCAPE ARCHITECT DRAWINGS INSOFAR AS THE PANEL TOP ELEVATIONS ARE EQUAL TO OR ABOVE THE DESIGN FLOOD ELEVATION.

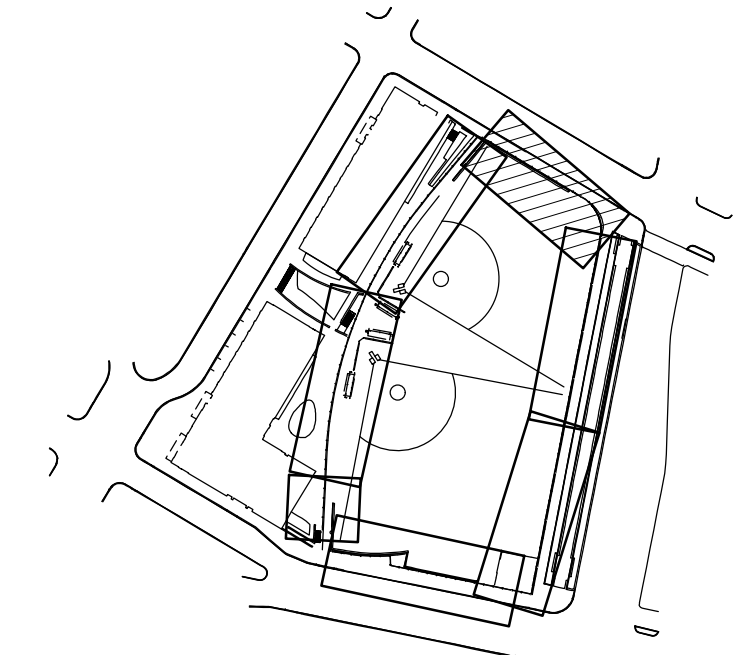

KEY PLAN
 NOT TO SCALE

PROJECT IDENTIFICATION

NEW YORK STATE OF OPPORTUNITY
Battery Park City Authority
 BATTERY PARK CITY
 BALLFIELD AND COMMUNITY CENTER

MARK	DATE	DESCRIPTION	BY
C	11/01/19	ISSUED FOR BID- 95%	AC
B	10/18/19	75% DESIGN SUBMITTAL	AC
A	09/06/19	50% DESIGN SUBMITTAL	AC

ISSUE BLOCK

PROJECT NO.:	3019666
DESIGNED BY:	N. TOLLI
DRAWN BY:	T. WISE
CHECKED BY:	A. CERINO P.E.
APPROVED BY:	A. CERINO P.E.
COPYRIGHT:	STV, INC

SHEET TITLE

PERIMETER PLAN SHEET
 4 OF 4

S-104

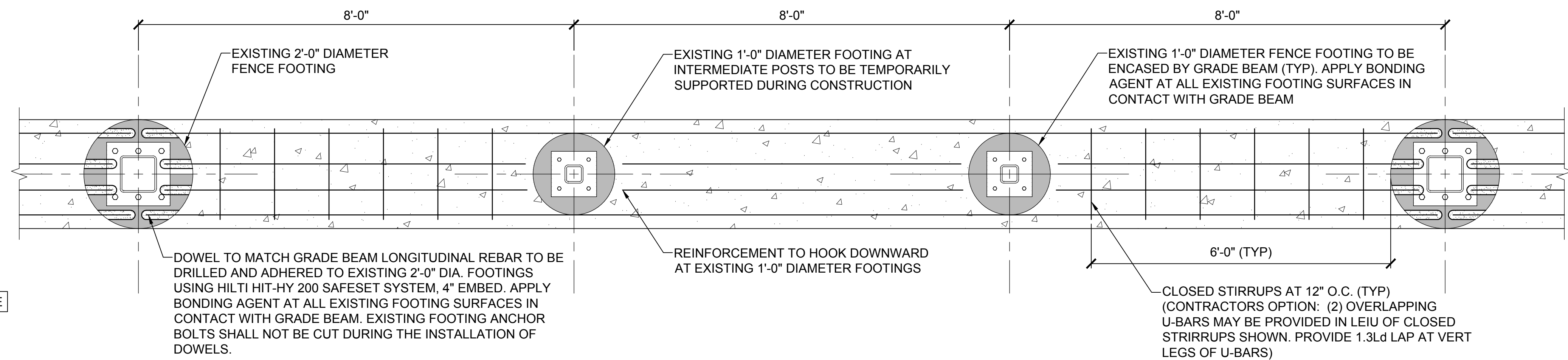

2 GRADE BEAM CONNECTION DETAIL AT EXISTING FENCE TO REMAIN
 1 1/2"=1'-0" 0 1' 1' 6"

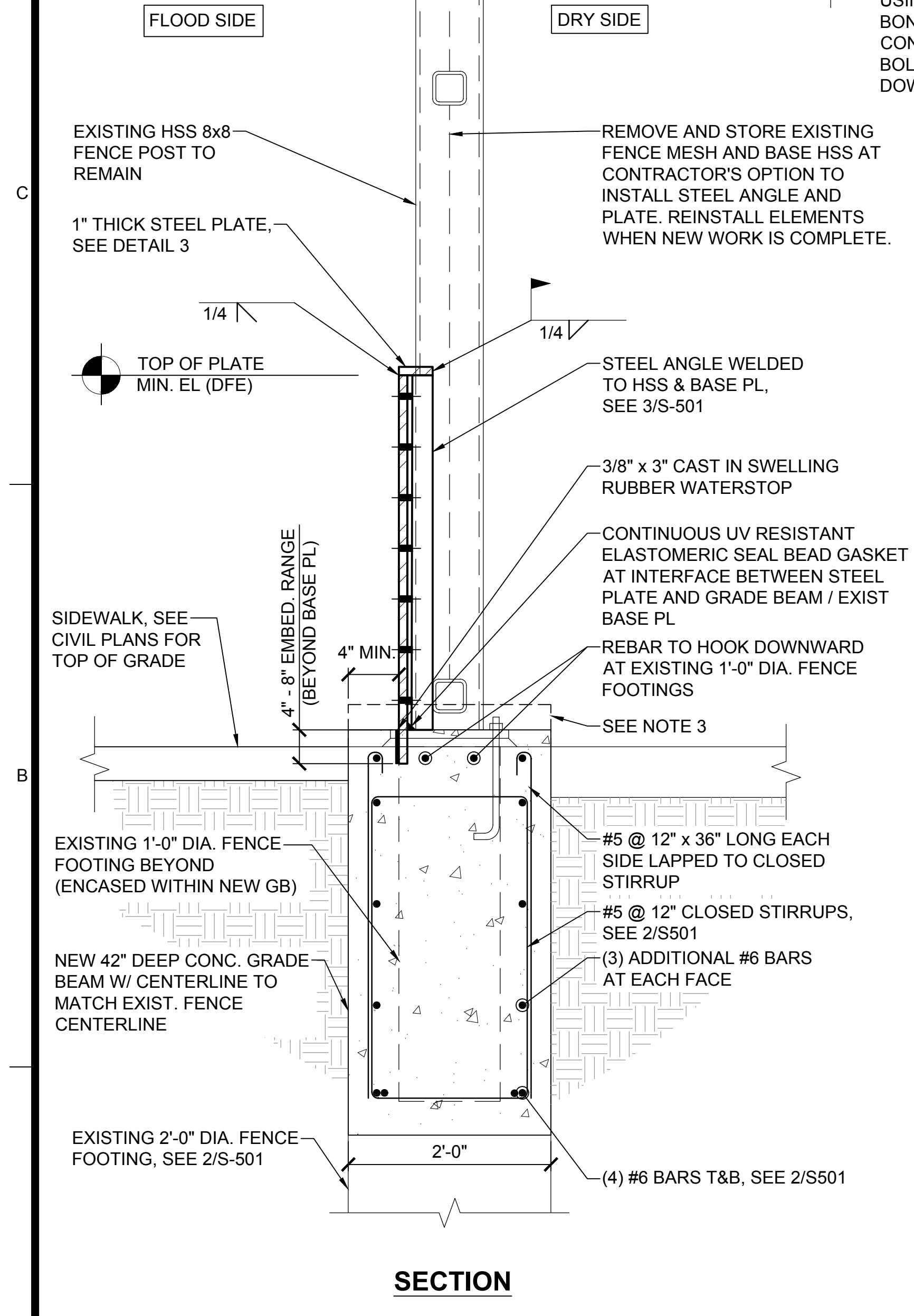

1 STEEL PLATE FLOOD WALL SECTION
 1"=1'-0" 0 1' 2'

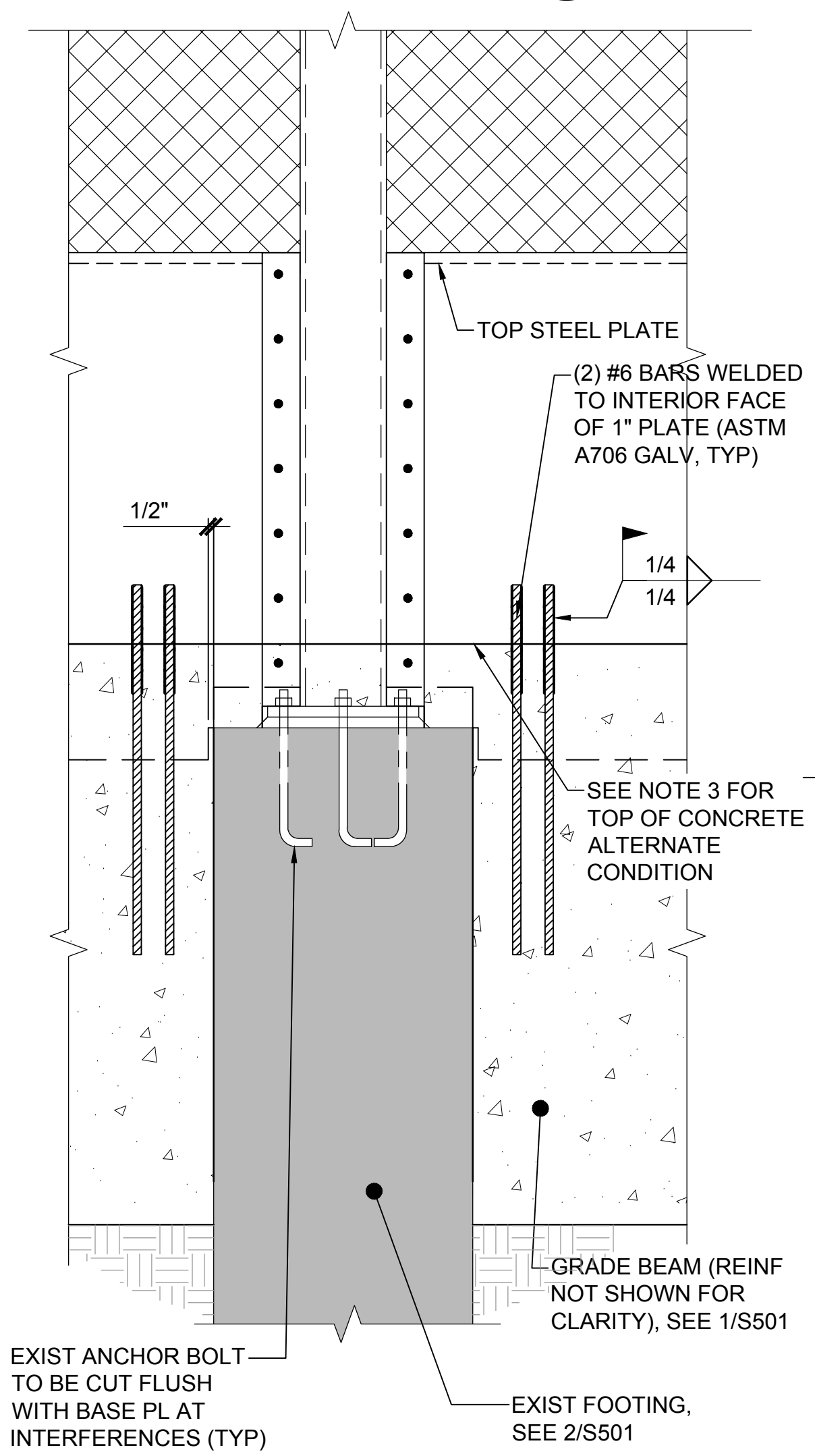

ELEVATION

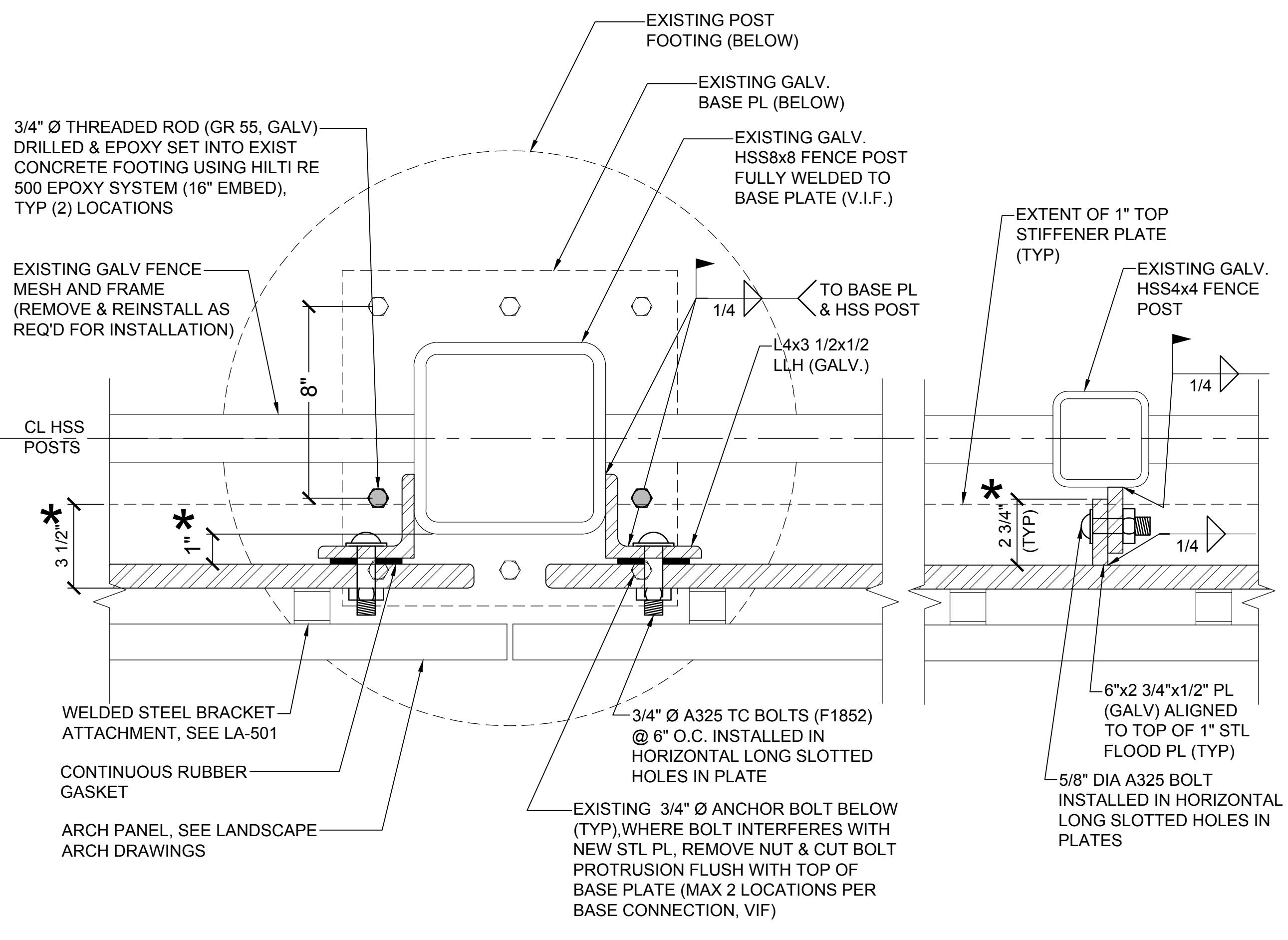

3 STEEL PLATE TO EXISTING POST CONNECTION DETAIL
 3"=1'-0" 0 3' 6' 9"

1 S-501
 1"=1'-0" 0 1' 2'

- NOTES:
- EXCAVATION DEPTH EXCEEDS DEPTH OF EXISTING HSS4x4 FENCE FOUNDATIONS. PROVIDE BRACING AS REQUIRED TO MAINTAIN STABILITY AND PLUMBNESS OF FENCE ELEMENTS DURING CONSTRUCTION. DESIGN OF BRACING ELEMENTS AND METHODOLOGY TO BE DETERMINED BY CONTRACTOR'S ENGINEER. SEE S-001 "SPECIAL CONSTRUCTION CONSIDERATIONS" NOTE 2.
 - WHERE STEEL PLATE FLOODWALL IS FACETED IN PLAN, PROVIDE BENT PLATES AT CONNECTION TO COLUMN IN LIEU OF ANGLES SHOWN.
 - IF TOP OF CONCRETE GRADE BEAM IS NOT A MINIMUM OF 4" ABOVE THE EXISTING FENCE BASE PLATE, PROVIDE LOCAL NOTCHING OF CONCRETE AS SHOWN IN DETAIL 1/S-508.
 - THE PROJECT INTENT IS FOR GRADE BEAM ALIGNMENT TO FOLLOW THE ALIGNMENT OF EXISTING HSS8x8 SONOTUBE FOOTINGS. THE MINIMUM COVER DIMENSION OF PLATE MUST BE MAINTAINED WHERE THERE ARE VARIATIONS IN EXISTING CONDITIONS.

- NOTES:
- ALL STEEL PLATE SEGMENTS MUST SPAN BETWEEN AND TERMINATE AT EXISTING OR NEW HSS8x8 POSTS WHERE THE FLOOD WALL IS NOT CONCRETE.
 - * REPRESENTS THE DIMENSION AT THE OUTERMOST POST IN A GIVEN STREET SEGMENT. THIS DIMENSION CAN GROW BY AN ADDITIONAL INCH TO ACCOUNT FOR LOCATION VARIATIONS. SHOULD THE REQUIRED SURVEY REVEAL LOCATION WHERE A 1" VARIATION IS EXCEEDED, INCREASE THE ANGLE LEG SIMILARLY TO ENSURE A PROPER CONNECTION. THE PROJECT INTENT IS FOR THE STEEL PLATE TO BE AS STRAIGHT AS POSSIBLE ON EACH STREET REGARDLESS OF VARIATIONS IN THE EXISTING FENCE POST LOCATION.

SEALS

PROJECT IDENTIFICATION
 NEW YORK STATE OF OPPORTUNITY
Battery Park City Authority
 BATTERY PARK CITY BALLFIELD AND COMMUNITY CENTER

MARK	DATE	DESCRIPTION	BY
C	11/01/19	ISSUED FOR BID- 95%	AC
B	10/18/19	75% DESIGN SUBMITTAL	AC
A	09/06/19	50% DESIGN SUBMITTAL	AC

ISSUE BLOCK

PROJECT NO.:	3019666
DESIGNED BY:	N. TOLLI
DRAWN BY:	N. TOLLI
CHECKED BY:	A. CERINO P.E.
APPROVED BY:	A. CERINO P.E.
COPYRIGHT:	STV, INC

SHEET TITLE
STEEL PLATE WALL SECTIONS AND DETAILS
 S-501

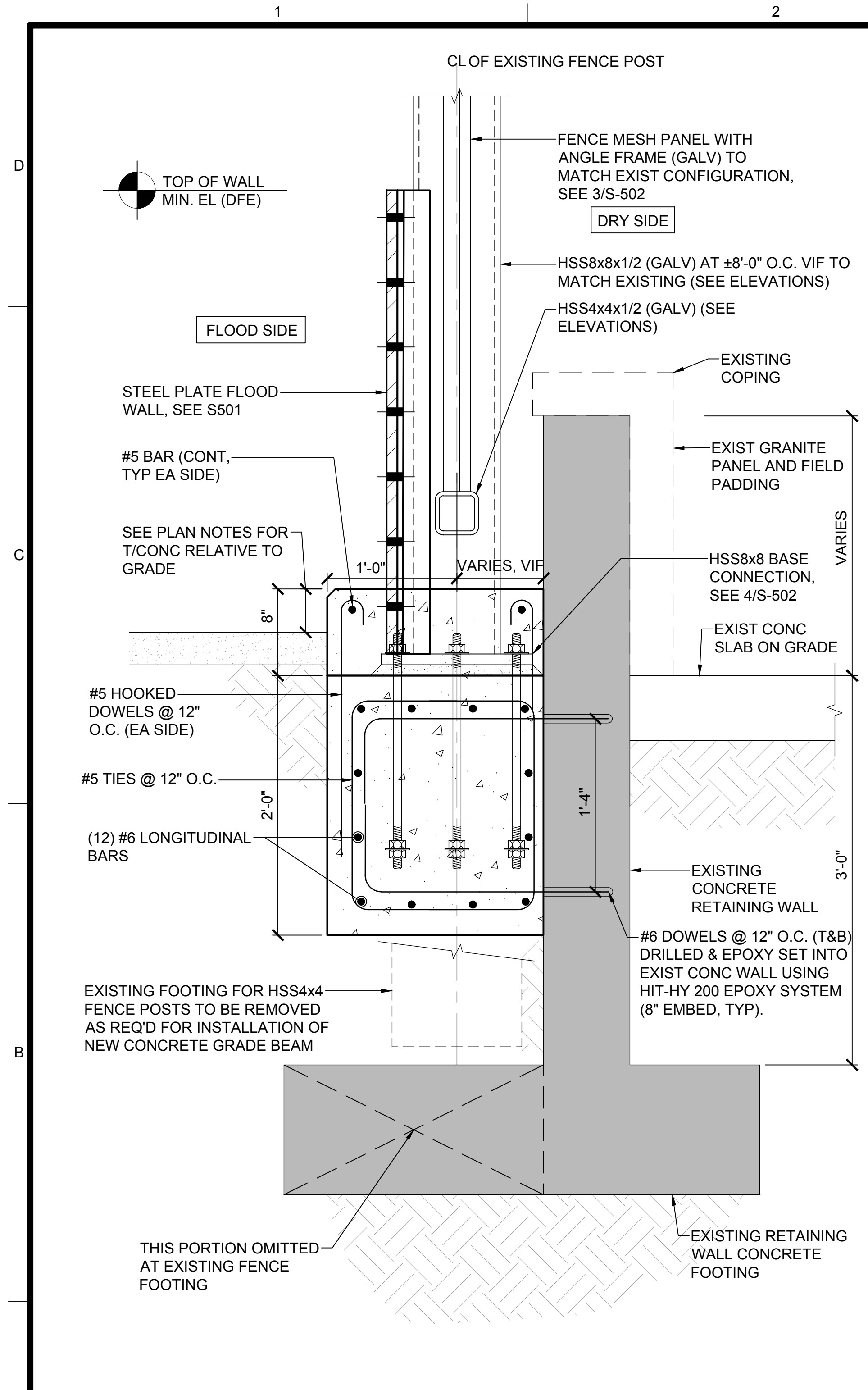

1 FLOODWALL DETAIL AT EXISTING 8'-0" FENCE
 S-502 1 1/2"=1'-0" 0 1' 1.6"

- NOTES:
- CONTRACTOR SHALL USE GROUND PENETRATING RADAR (GPR) TO IDENTIFY LOCATION OF EXISTING REINFORCEMENT IN ORDER TO AVOID CUTTING REINFORCEMENT DURING INSTALLATION OF NEW DOWELS.
 - DIMENSION FROM CENTERLINE OF POST TO FACE OF GRADE BEAM TO MATCH DIMENSION FROM CENTERLINE OF POST TO EXISTING FACE OF HSS8x8 SONOTUBE FOOTING AT RETAINING WALL WITH EXISTING 24'-0" FENCE PER EXISTING DRAWINGS.

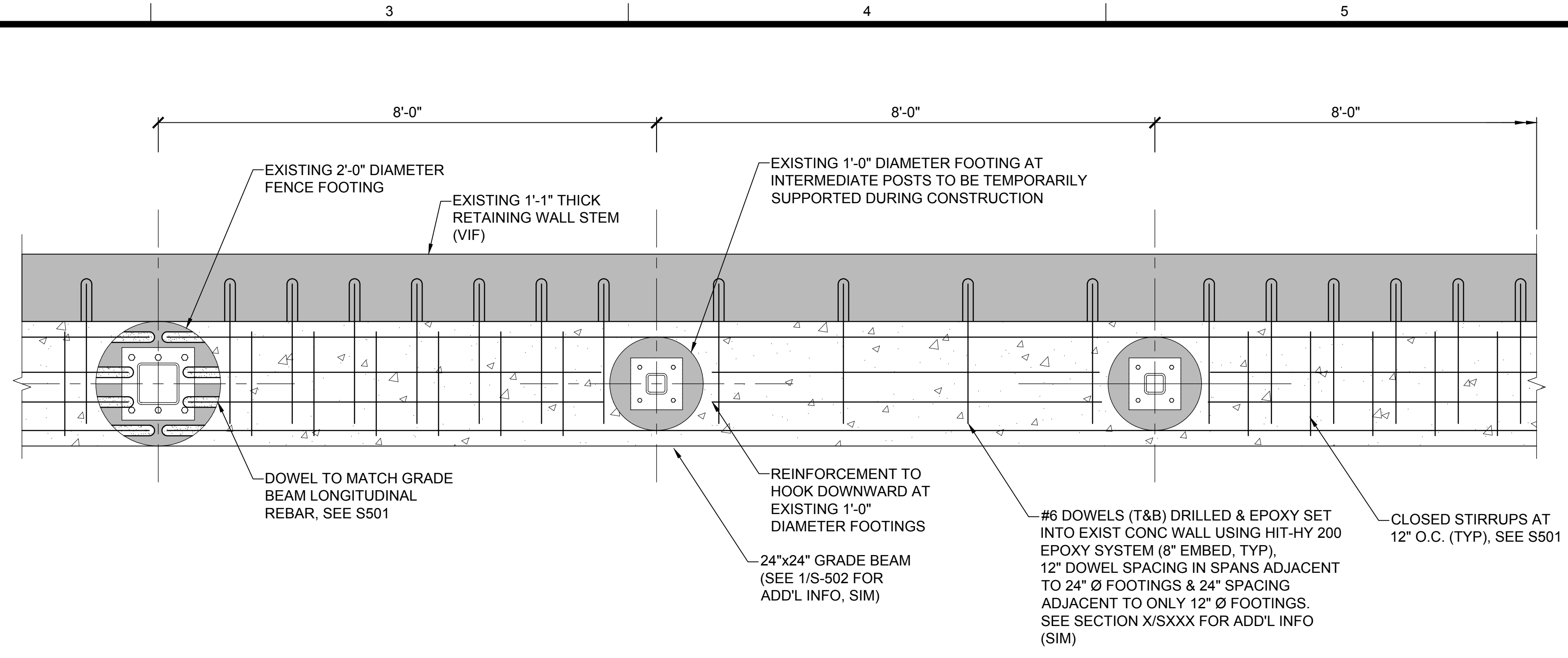

2 FOUNDATION REINFORCING DETAIL AT EXISTING RETAINING WALL AT 24'-0" FENCE
 S-502 3/4"=1'-0" 0 1' 2' 3"

- NOTES:
- REFER TO DETAIL 2/S501 FOR ADD'L INFORMATION NOT SHOWN.
 - CONTRACTOR SHALL USE GROUND PENETRATING RADAR (GPR) TO IDENTIFY LOCATION OF EXISTING REINFORCEMENT IN ORDER TO AVOID CUTTING REINFORCEMENT DURING INSTALLATION OF NEW DOWELS.

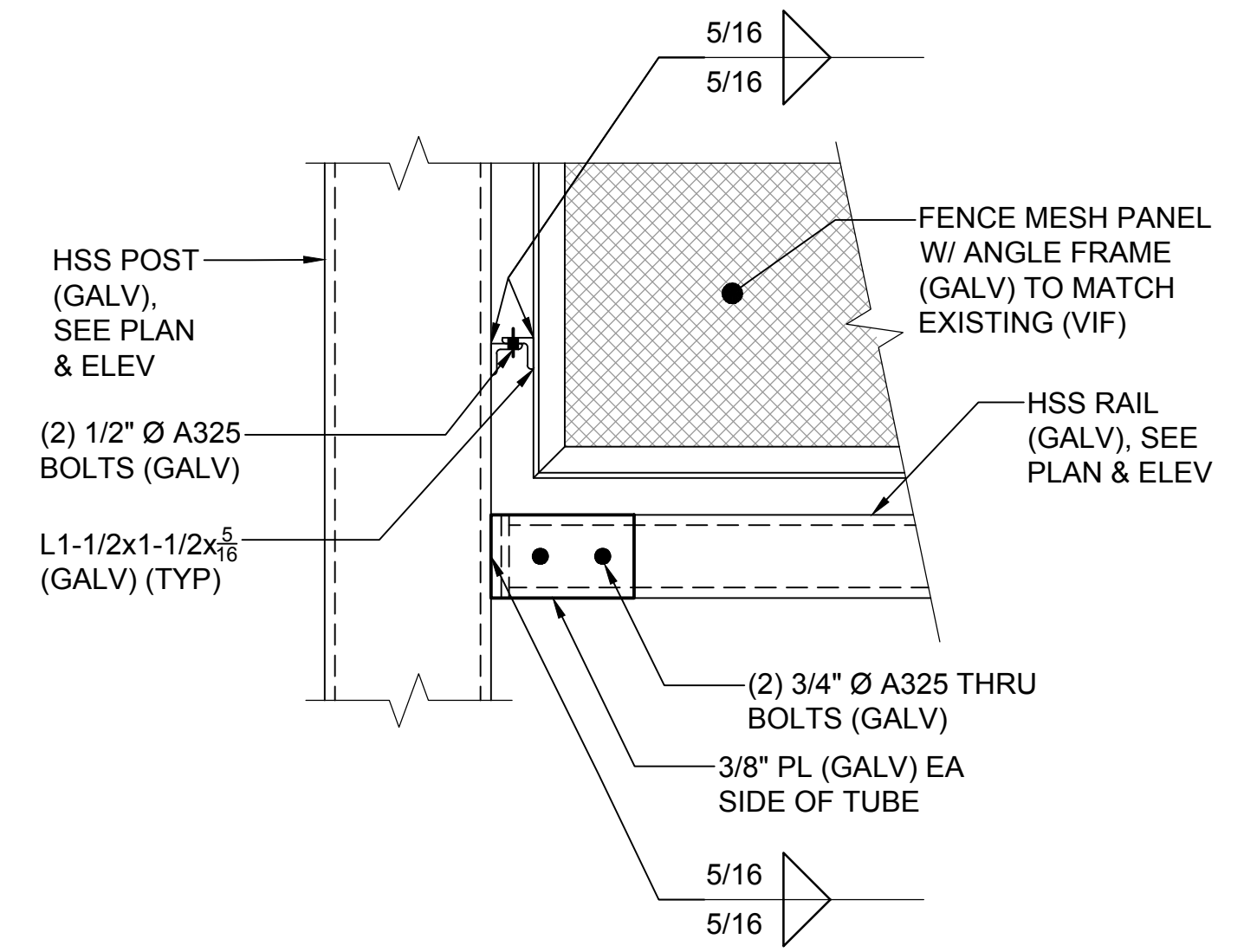

3 FENCE MESH CONNECTION DETAIL
 S-502 1"=1'-0" 0 1' 2"

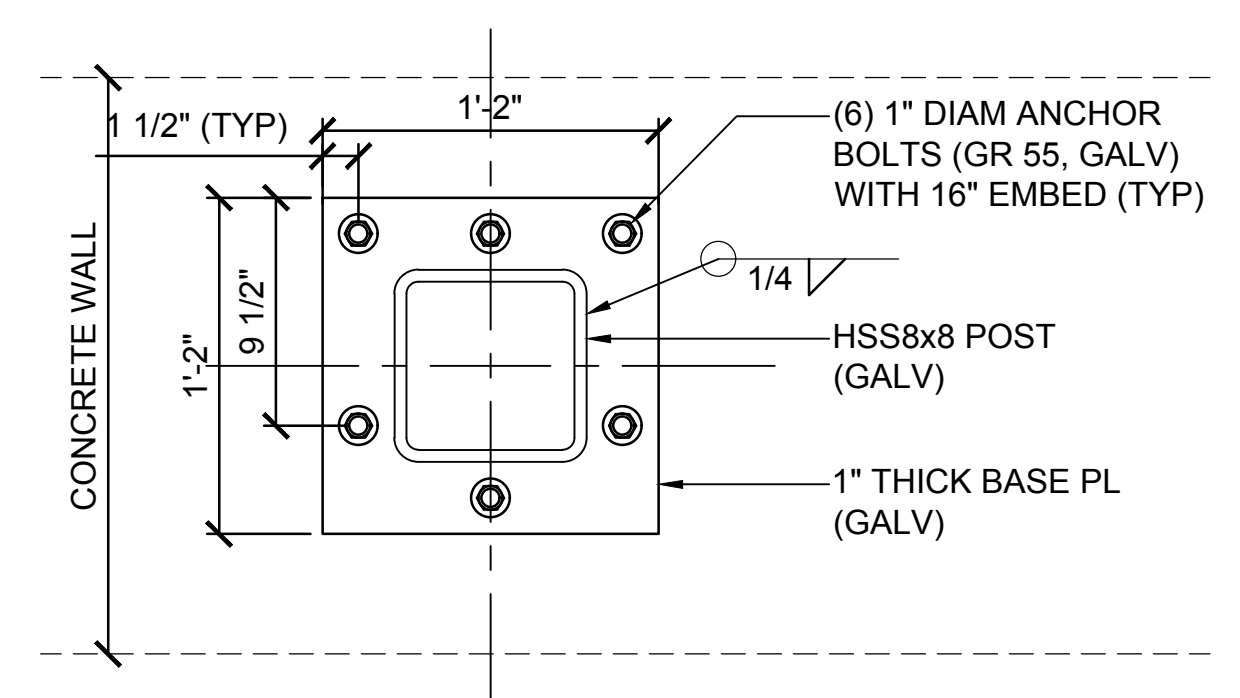

4 HSS8x8 BASE PLATE DETAIL
 S-502 1"=1'-0" 0 1' 2"

MARK	DATE	DESCRIPTION	BY
C	11/01/19	ISSUED FOR BID- 95%	AC
B	10/18/19	75% DESIGN SUBMITTAL	AC
A	09/06/19	50% DESIGN SUBMITTAL	AC

ISSUE BLOCK

PROJECT NO.:	3019666
DESIGNED BY:	N. TOLLI
DRAWN BY:	N. TOLLI
CHECKED BY:	A. CERINO P.E.
APPROVED BY:	A. CERINO P.E.
COPYRIGHT:	STV, INC

MARK	DATE	DESCRIPTION	BY
C	11/01/19	ISSUED FOR BID- 95%	AC
B	10/18/19	75% DESIGN SUBMITTAL	AC
A	09/06/19	50% DESIGN SUBMITTAL	AC

ISSUE BLOCK

PROJECT NO.:	3019666
DESIGNED BY:	N. TOLLI
DRAWN BY:	N. TOLLI
CHECKED BY:	A. CERINO P.E.
APPROVED BY:	A. CERINO P.E.
COPYRIGHT:	STV, INC

SHEET TITLE
CONCRETE WALL SECTIONS AND DETAILS

S-503

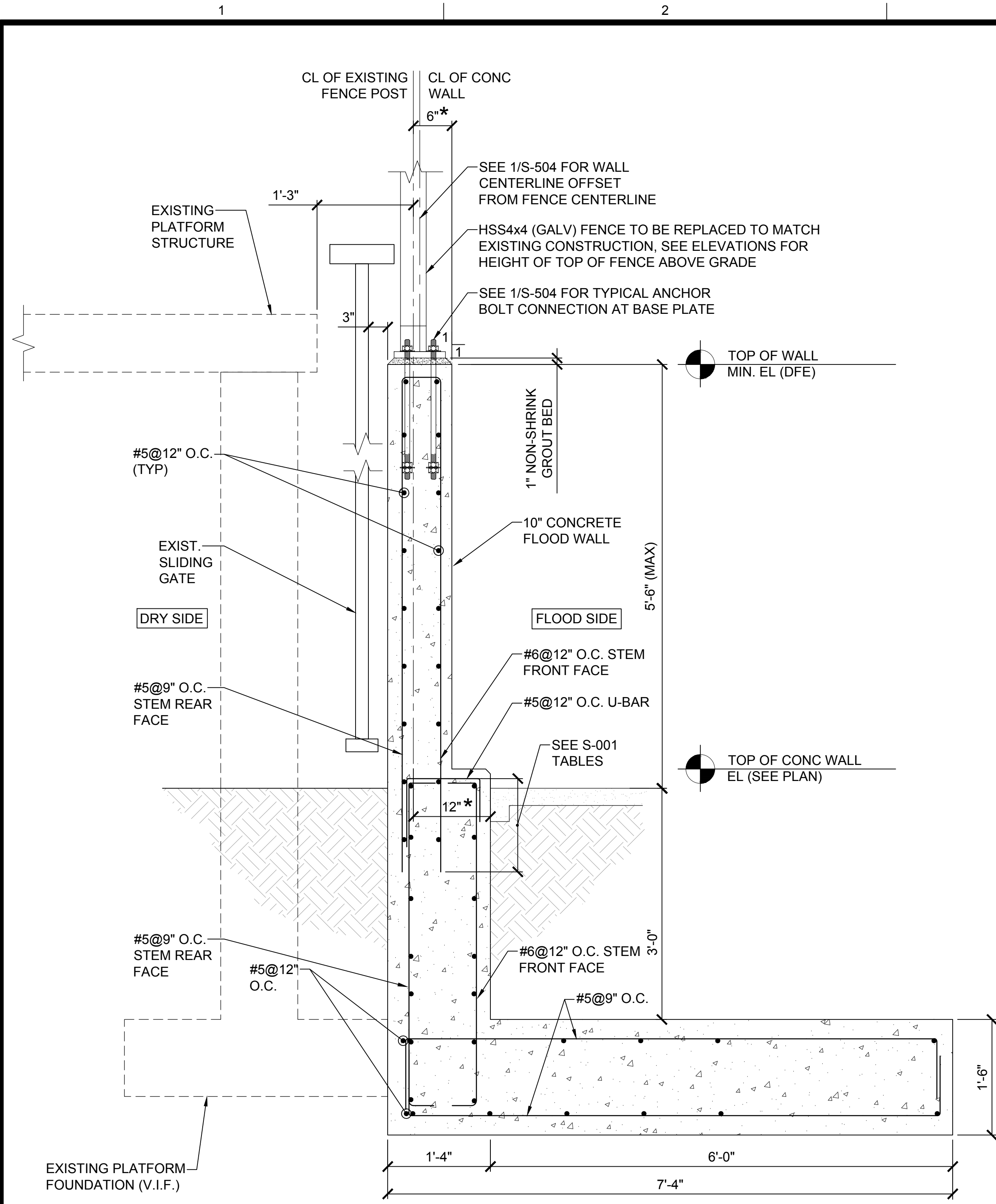

1 CONCRETE WALL SECTION
 S-503 1"=1'-0"

- NOTES:
- PROJECT INTENT IS FOR NEW SECURITY FENCE ALIGNMENT TO MATCH EXISTING FENCE ALIGNMENT AND FOR CONCRETE WALL FACE TO MATCH STEEL PLATE FACE ON EACH STREET SIDE.
 - * DIMENSIONS REPRESENT THE DIMENSION AT THE OUTERMOST POST IN A GIVEN STREET SEGMENT. THIS DIMENSION CAN GROW BY AN ADDITIONAL INCH TO ACCOUNT FOR LOCATION VARIATIONS. SHOULD THE REQUIRED SURVEY REVEAL LOCATIONS WHERE A 1" VARIATION IS EXCEEDED, THE ALIGNMENT OF THE CONCRETE WALL AND FENCE ON TOP OF CONCRETE WALL SHALL BE ADJUSTED TO ENSURE THE FACE OF THE STEEL PLATE AND CONCRETE WALL MATCH.
 - VERIFY CLEARANCE BETWEEN EXISTING ELECTRICAL EQUIPMENT PLATFORM FOUNDATIONS, SLIDING GATE FOUNDATIONS AND NEW CONCRETE WALL FOUNDATIONS.

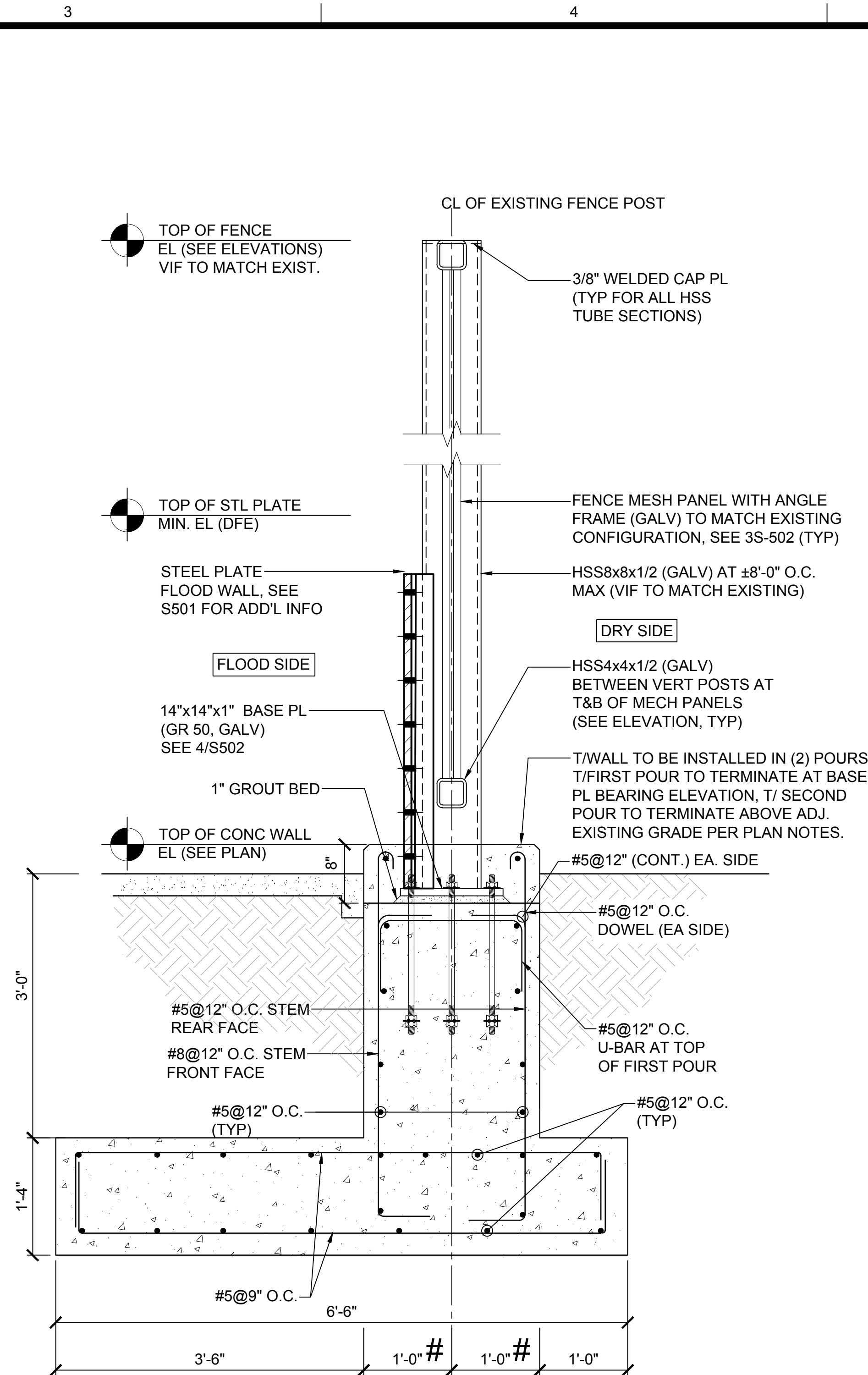

2 STEEL PLATE AT NEW FOUNDATION SECTION
 S-503 1"=1'-0"

- NOTES:
- PROJECT INTENT IS FOR NEW SECURITY FENCE ALIGNMENT TO MATCH EXISTING FENCE ALIGNMENT AND FOR CONCRETE WALL FACE TO MATCH STEEL PLATE FACE AT INTERFACE BETWEEN DETAILS. ALIGNMENT OF FOUNDATION CURB FACE SHOULD MATCH THE CURB FACE AT NEW GRADE BEAM AND NEW CONCRETE WALL SECTION.
 - # DIMENSIONS ASSUME THAT FOOTING LINES UP WITH A GRADE BEAM CENTERED ON THE EXISTING FENCE CENTERLINE. ALIGNMENT OF GRADE BEAM CAN VARY BASED ON WHETHER OR NOT THE EXISTING FENCE ARE CENTERED ON THEIR SONOTUBE FOUNDATIONS. SHOULD THE GRADE BEAM NOT BE CENTERED ON THE EXISTING FENCE CENTERLINE, THE ALIGNMENT OF THE FOOTING SHALL BE ADJUSTED TO HAVE FACE OF GRADE BEAM AND FACE OF FOOTING MATCH. SEE 1/S-501 FOR GRADE BEAM ALIGNMENT AND MINIMUM ALLOWABLE STEEL PLATE CONCRETE COVER.

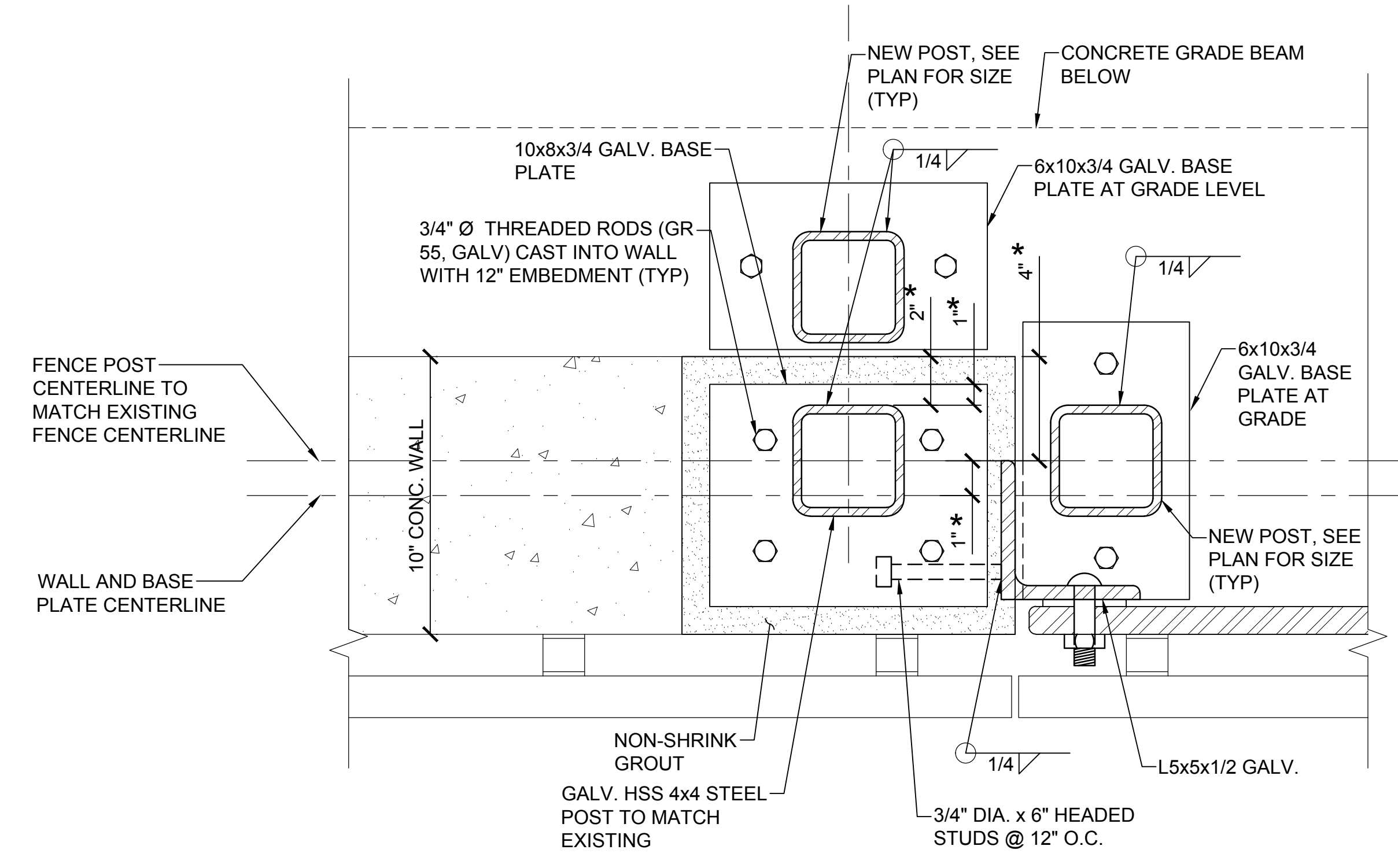

1 CONCRETE WALL TO STEEL PLATE TRANSITION DETAIL

S-504 1"=1'-0" 0 1' 2'

- NOTES:
- PROJECT INTENT IS FOR NEW SECURITY FENCE ALIGNMENT TO MATCH EXISTING FENCE ALIGNMENT AND FOR CONCRETE WALL FACE TO MATCH STEEL PLATE FACE ON EACH STREET SIDE.
 - * DIMENSIONS REPRESENTS THE DIMENSION AT THE OUTERMOST POST IN A GIVEN STREET SEGMENT. THIS DIMENSION CAN GROW BY AN ADDITIONAL INCH TO ACCOUNT FOR LOCATION VARIATIONS. SHOULD THE REQUIRED SURVEY REVEAL LOCATIONS WHERE A 1" VARIATION IS EXCEEDED, THE ALIGNMENT OF THE CONCRETE WALL AND FENCE ON TOP OF CONCRETE WALL SHALL BE ADJUSTED TO ENSURE THE FACE OF THE STEEL PLATE AND CONCRETE WALL MATCH.

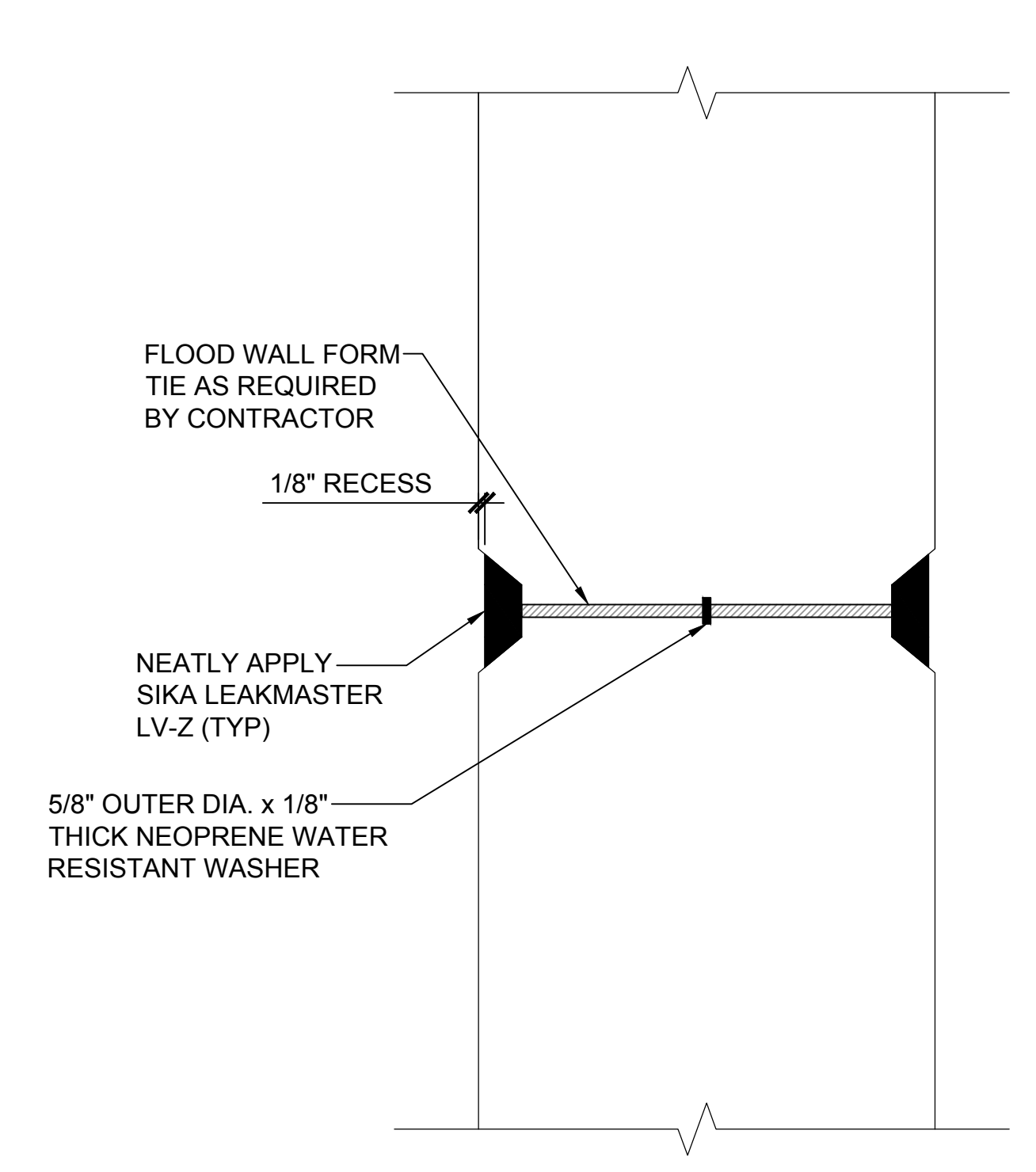

2 TYPICAL FORM TIE DETAIL

S-504 NOT TO SCALE

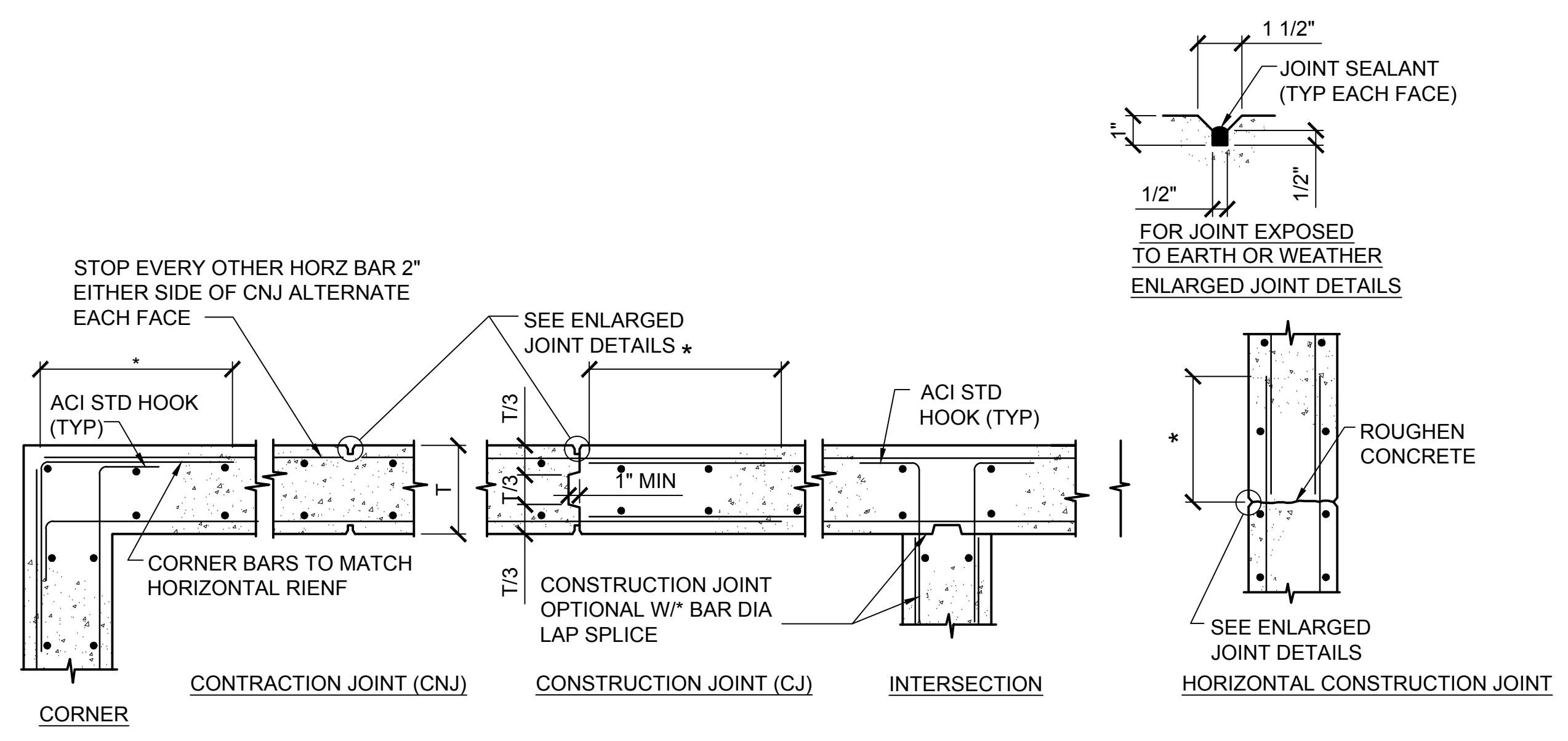

3 TYPICAL CONCRETE WALL JOINT DETAILS

S-504 NOT TO SCALE

- * REFER TO GENERAL NOTES FOR CONCRETE DEVELOPMENT LENGTH TABLE.
- PROVIDE V-GROOVE AT VERTICAL CONSTRUCTION JOINTS ONLY.
- T = WALL THICKNESS
- SEE ELEVATIONS FOR WALL JOINT LOCATIONS.

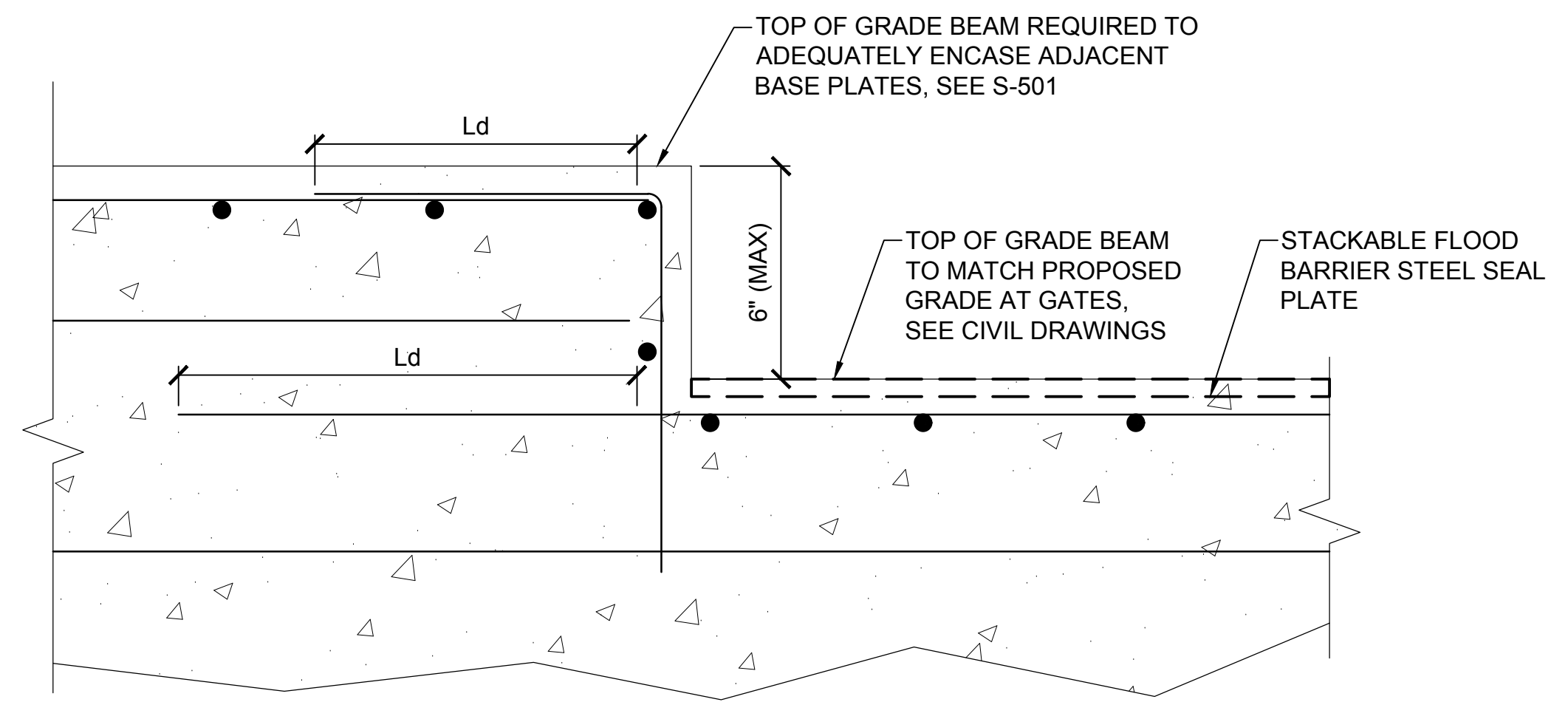

4 TYPICAL STEPPED FOUNDATION DETAIL AT GATES

S-504 NOT TO SCALE

STV 100 Years
 STV INCORPORATED
 225 PARK AVENUE SOUTH
 5TH FLOOR
 NEW YORK, NY 10003
 www.stvinc.com

CONSULTANTS
SITWORKS
 LANDSCAPE ARCHITECTURE, LLC
 150 WEST 28TH STREET
 SUITE 605
 NEW YORK, NY 10001
 www.sitworkscom.com

SEALS

PROJECT IDENTIFICATION
 NEW YORK STATE OF OPPORTUNITY
Battery Park City Authority
 BATTERY PARK CITY
 BALLFIELD AND COMMUNITY CENTER

MARK	DATE	DESCRIPTION	BY
C	11/01/19	ISSUED FOR BID- 95%	AC
B	10/18/19	75% DESIGN SUBMITTAL	AC
A	09/06/19	50% DESIGN SUBMITTAL	AC

ISSUE BLOCK

PROJECT NO.:	3019666
DESIGNED BY:	N. TOLLI
DRAWN BY:	N. TOLLI
CHECKED BY:	A. CERINO P.E.
APPROVED BY:	A. CERINO P.E.
COPYRIGHT:	STV, INC

SHEET TITLE
CONCRETE DETAILS

S-504

MARK	DATE	DESCRIPTION	BY
A	11/01/19	ISSUED FOR BID- 95%	AC

ISSUE BLOCK

PROJECT NO.:	3019666
DESIGNED BY:	
DRAWN BY:	
CHECKED BY:	A. CERINO P.E.
APPROVED BY:	A. CERINO P.E.
COPYRIGHT:	STV, INC

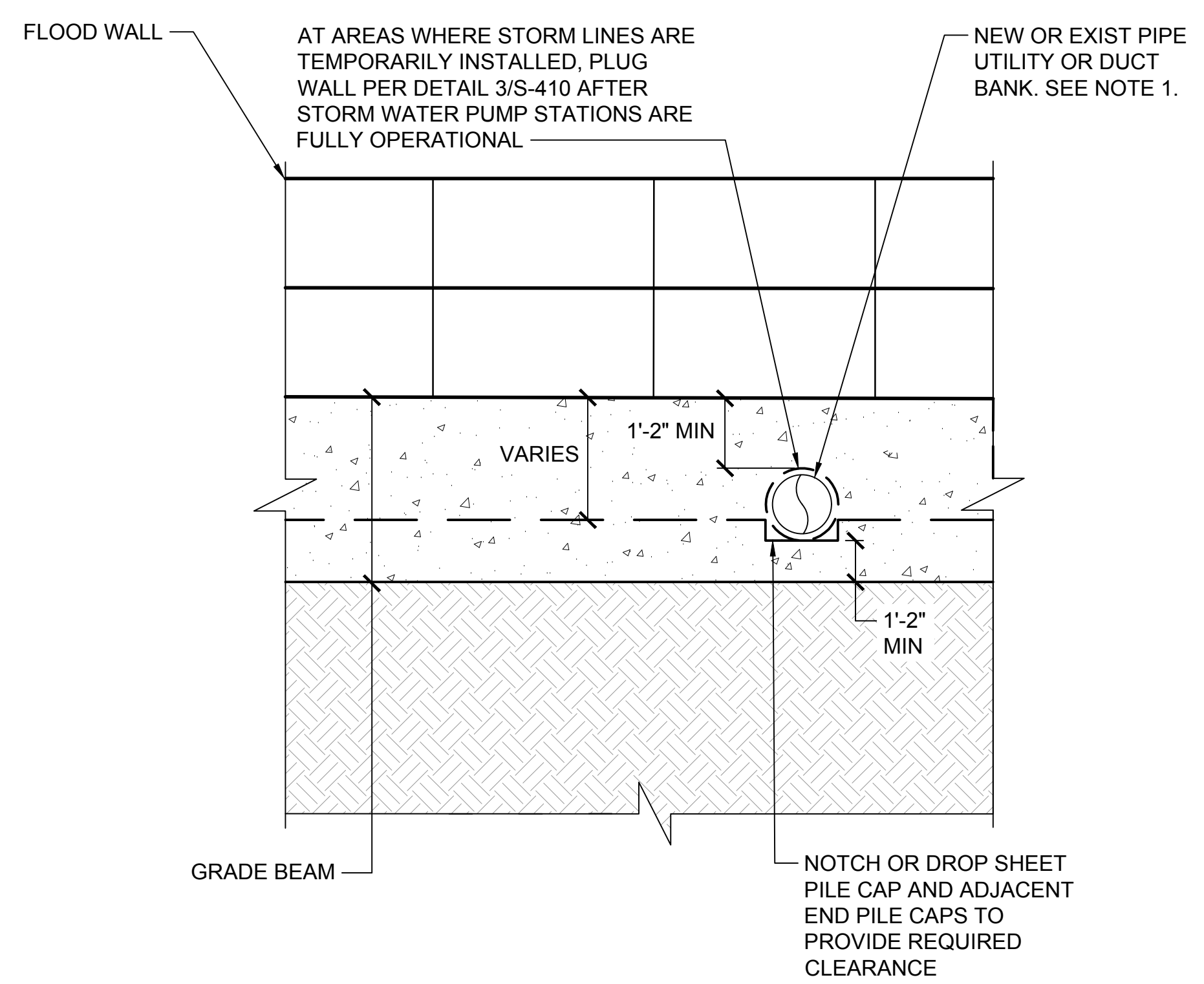

1 TYPICAL UTILITY SPAN THROUGH GRADE BEAM OR FOOTING
 S-505 NOT TO SCALE

- NOTES:
1. PROVIDE STANDARD WEIGHT PIPE SLEEVE AT EACH NEW AND EXISTING PIPE UTILITY. SEE PIPE SLEEVE DETAIL 2/S-505. FOR DETAIL AT DUCT BANK SEE 3/S-505.

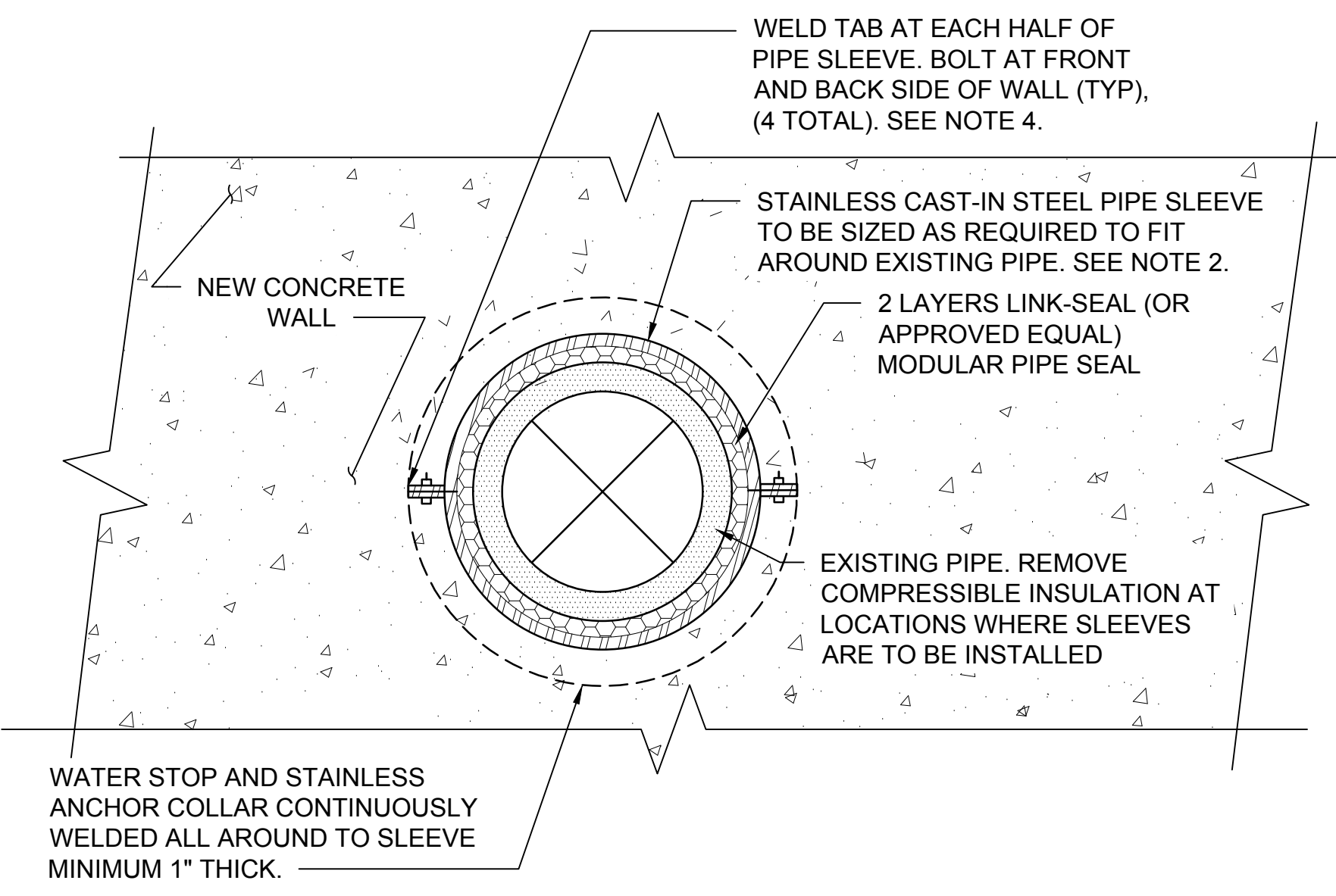

2 TYPICAL UTILITY SPAN THROUGH GRADE BEAM OR FOOTING
 S-505 NOT TO SCALE

- NOTES:
1. SLEEVE DETAIL SHALL APPLY FOR ALL PIPES LARGER THAN 2" IN DIAMETER AND HOT-OPERATING PIPES OF ALL SIZES. SMALLER COLD PIPES AND ALL CONDUITS SHALL BE ENCASED DIRECTLY IN CONCRETE.
 2. SEE LINK-SEAL (OR APPROVED EQUAL) MANUFACTURER SPECIFICATIONS FOR REQUIRED PIPE SLEEVE SIZE & APPROPRIATE LINK-SEAL PRODUCT FOR SPECIFIC PIPE MATERIAL, DIAMETER, AND TYPE.
 3. FOR UTILITY WIDTH LESS THAN 24", PROVIDE (1) ADDITIONAL FULL HEIGHT VERTICAL TENSION AND COMPRESSION BAR AT EACH SIDE OF UTILITY TO MATCH VERTICAL REINFORCEMENT. FOR UTILITY WIDTH UP TO 48", PROVIDE (2) VERTICAL TENSION AND COMPRESSION BARS EACH SIDE. PROVIDE (2) #6 BARS AT TOP AND BOTTOM OF UTILITY WITH FULL DEVELOPMENT LENGTH PAST EDGE OF UTILITY.
 4. CAST-IN STEEL PIPE MAY BE WELDED IN PLACE IN LIEU OF BOLTING BUT IS NOT PERMITTED AT GAS LINES.
 5. FOR UTILITIES LESS THAN 2" PENETRATING THROUGH FOUNDATION, PLACE OR BEND REINFORCEMENT TO AVOID UTILITY AND ENCASE UTILITY DIRECTLY IN CONCRETE.
 6. FOR UTILITIES LARGER THAN 14" IN DIAMETER, THE ENGINEER SHALL BE NOTIFIED.

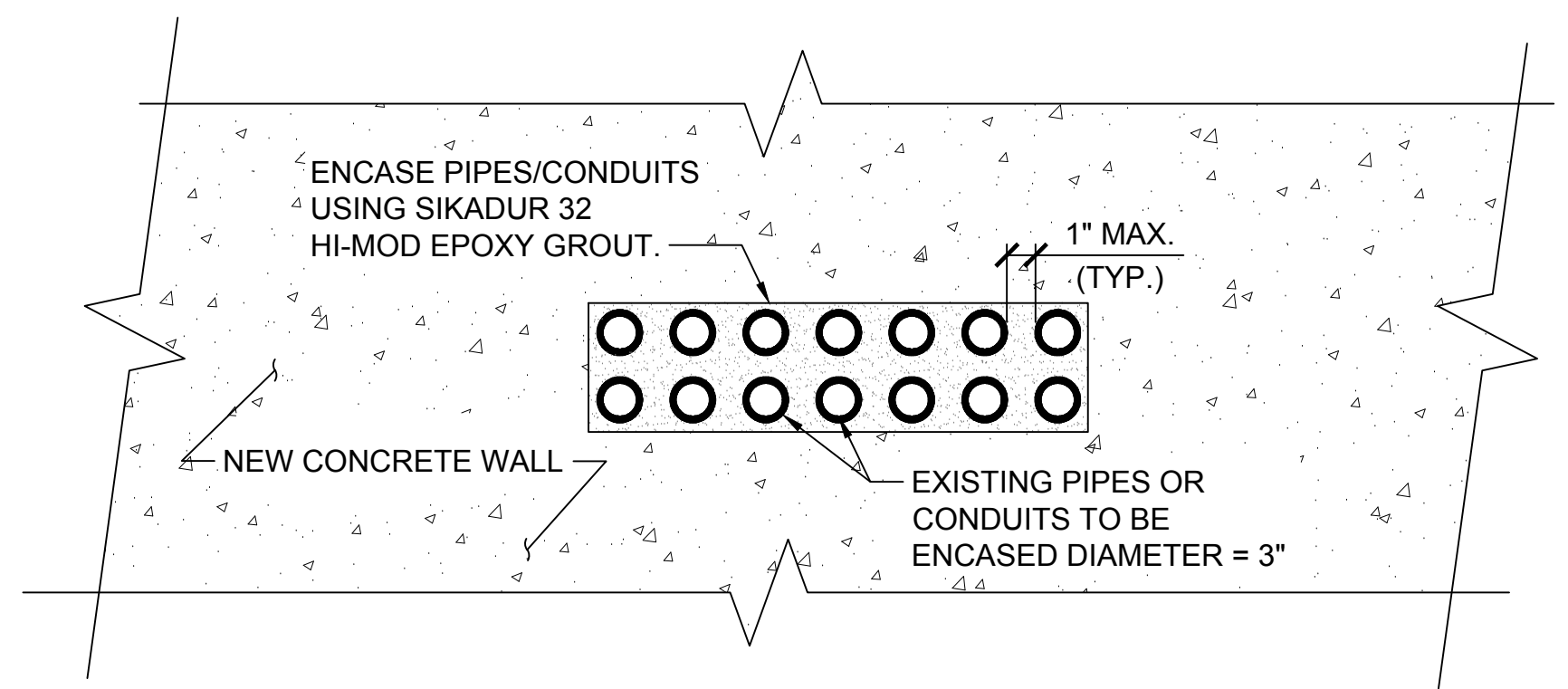

3 TYPICAL UTILITY GROUP PENETRATION DETAIL
 S-505 NOT TO SCALE

- NOTE:
1. FOR UTILITY GROUP WIDTH LESS THAN 24", PROVIDE (1) ADDITIONAL FULL HEIGHT VERTICAL TENSION AND COMPRESSION BAR AT EACH SIDE OF UTILITY GROUP TO MATCH VERTICAL WALL REINFORCEMENT. FOR UTILITY GROUP WIDTH UP TO 48", PROVIDE (2) VERTICAL TENSION AND COMPRESSION BARS EACH SIDE. PROVIDE (2) #6 BARS AT TOP AND BOTTOM OF UTILITY GROUP WITH FULL DEVELOPMENT LENGTH PAST EDGE OF UTILITY GROUP.

MARK	DATE	DESCRIPTION	BY
A	11/01/19	ISSUED FOR BID- 95%	AC

ISSUE BLOCK

PROJECT NO.:	3019666
DESIGNED BY:	N. TOLLI
DRAWN BY:	N. TOLLI
CHECKED BY:	A. CERINO P.E.
APPROVED BY:	A. CERINO P.E.
COPYRIGHT:	STV, INC

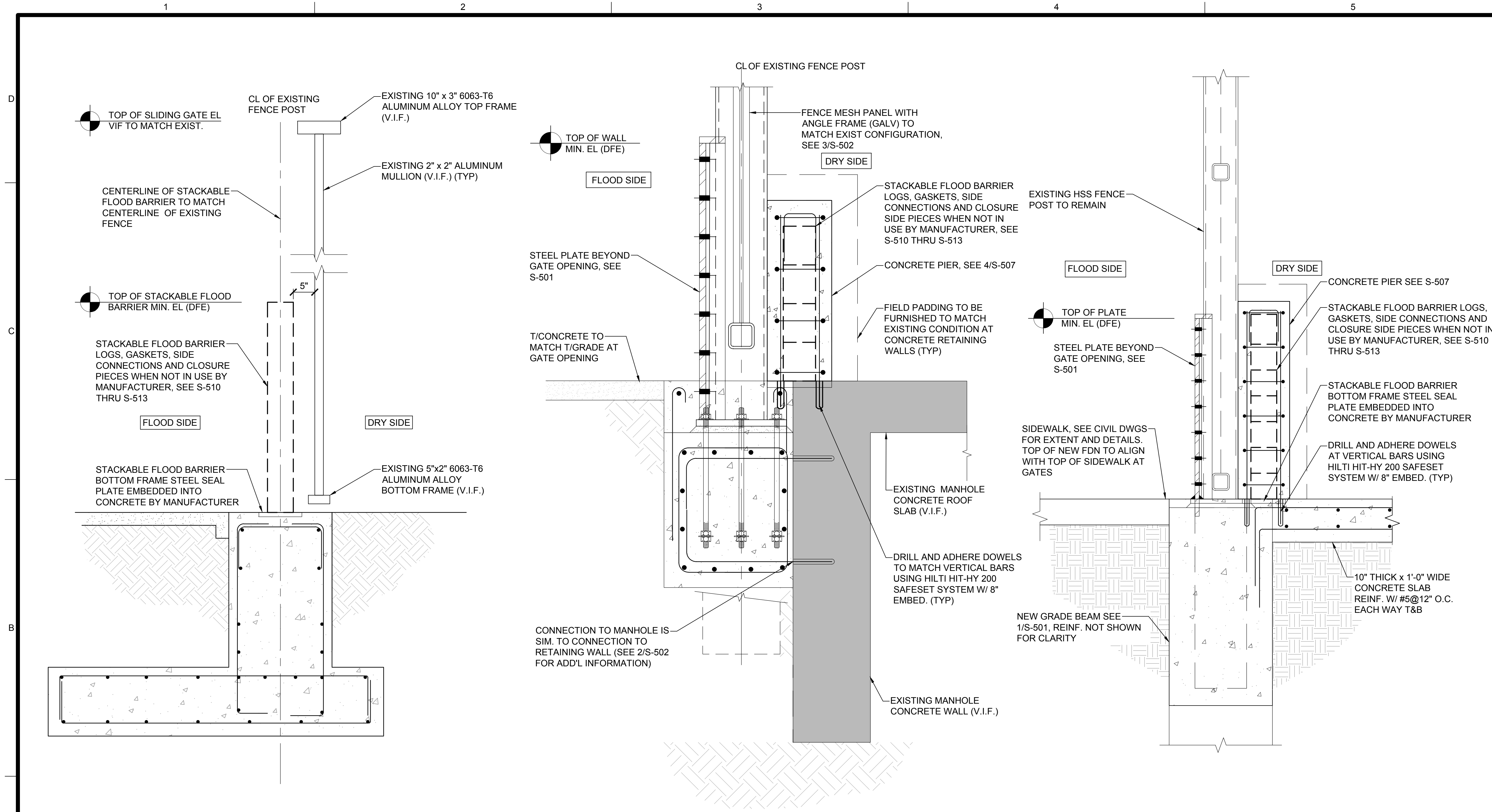

1 MURRAY STREET VEHICULAR GATE SECTION
 S-506 1"=1'-0" 0 1' 2'

NOTES:
 1. SEE 2/S-503 FOR ADDITIONAL INFORMATION NOT SHOWN.

2 MURRAY STREET PEDESTRIAN GATE SECTION
 S-506 1 1/2"=1'-0" 0 1' 1'6"

NOTES:
 1. SEE 1/S-502 FOR ADDITIONAL FOUNDATION INFORMATION NOT SHOWN.

3 WARREN STREET PEDESTRIAN GATE SECTION
 S-506 1"=1'-0" 0 1' 2'

NOTES:
 1. SEE S-501 FOR ADDITIONAL INFORMATION NOT SHOWN.

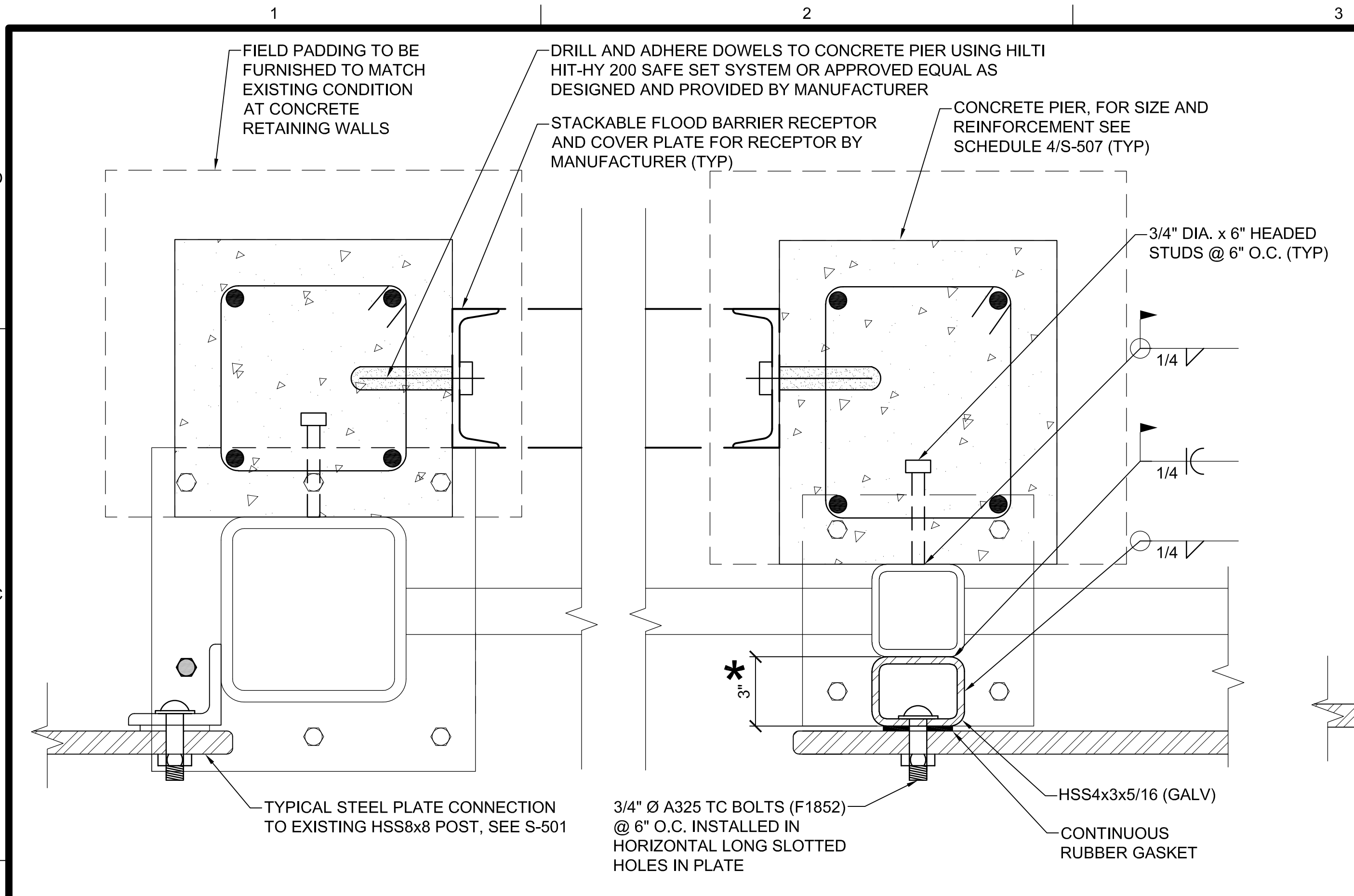

1 WARREN STREET PEDESTRIAN GATE PLAN DETAIL
 S-507 3"=1'-0" 0 3" 6" 9"

- NOTES:
1. TOP OF NEW HSS POST TO MATCH TOP OF STEEL PLATE. NEW HSS POST TO BE SEALED WITH A 3/8" CAP PLATE.
 2. * REPRESENTS THE DIMENSION AT THE OUTERMOST POST IN A GIVEN STREET SEGMENT. THIS DIMENSION CAN GROW BY AN ADDITIONAL INCH TO ACCOUNT FOR LOCATION VARIATIONS. SHOULD THE REQUIRED SURVEY REVEAL LOCATIONS WHERE A 1" VARIATION IS EXCEEDED, INCREASE THE STEEL TUBE SIZE SIMILAR TO ENSURE A PROPER CONNECTION. THE PROJECT INTENT IS FOR THE STEEL PLATE TO BE AS STRAIGHT AS POSSIBLE ON EACH STREET REGARDLESS OF VARIATIONS IN THE EXISTING FENCE POST LOCATION.

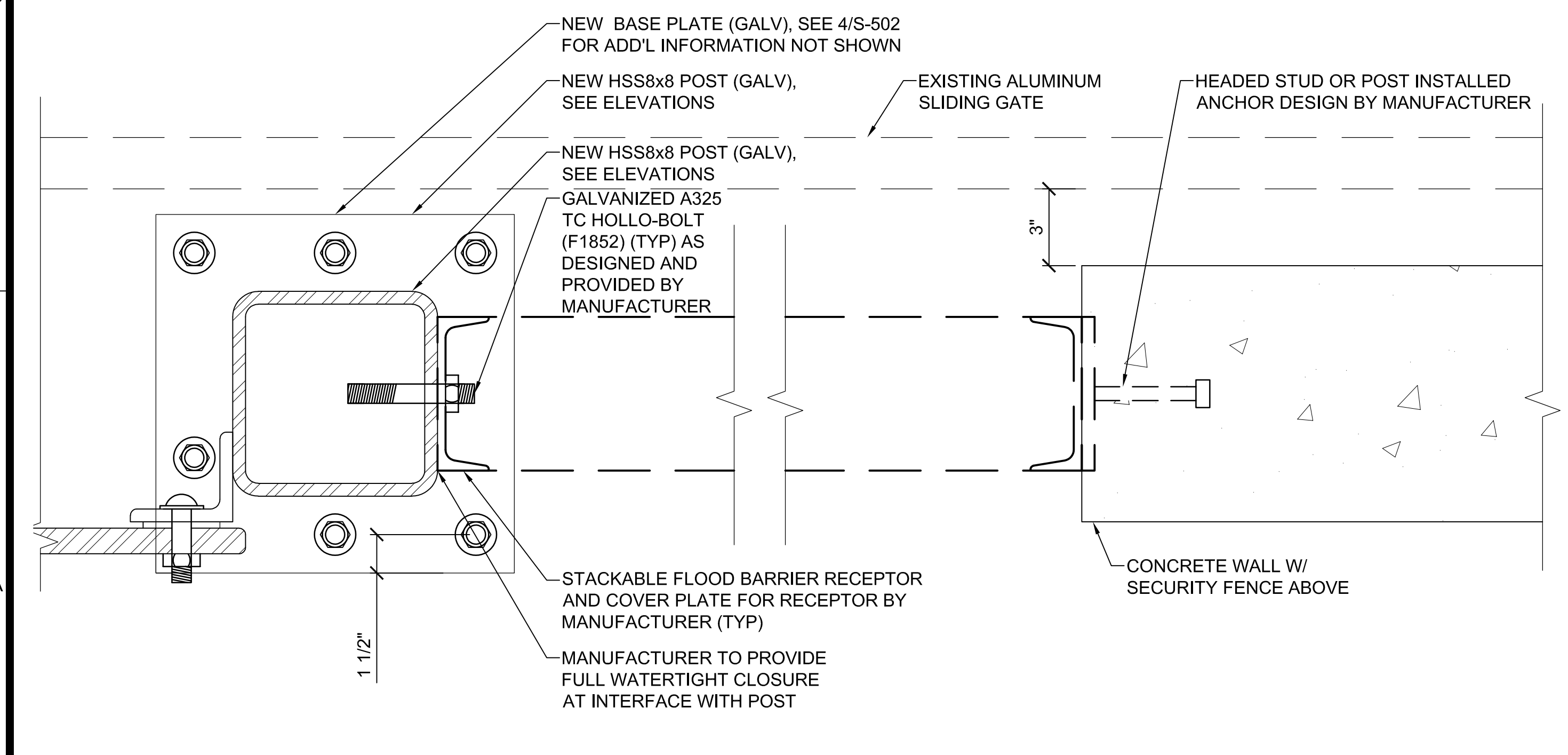

3 MURRAY STREET VEHICULAR GATE PLAN DETAIL
 S-507 3"=1'-0" 0 3" 6" 9"

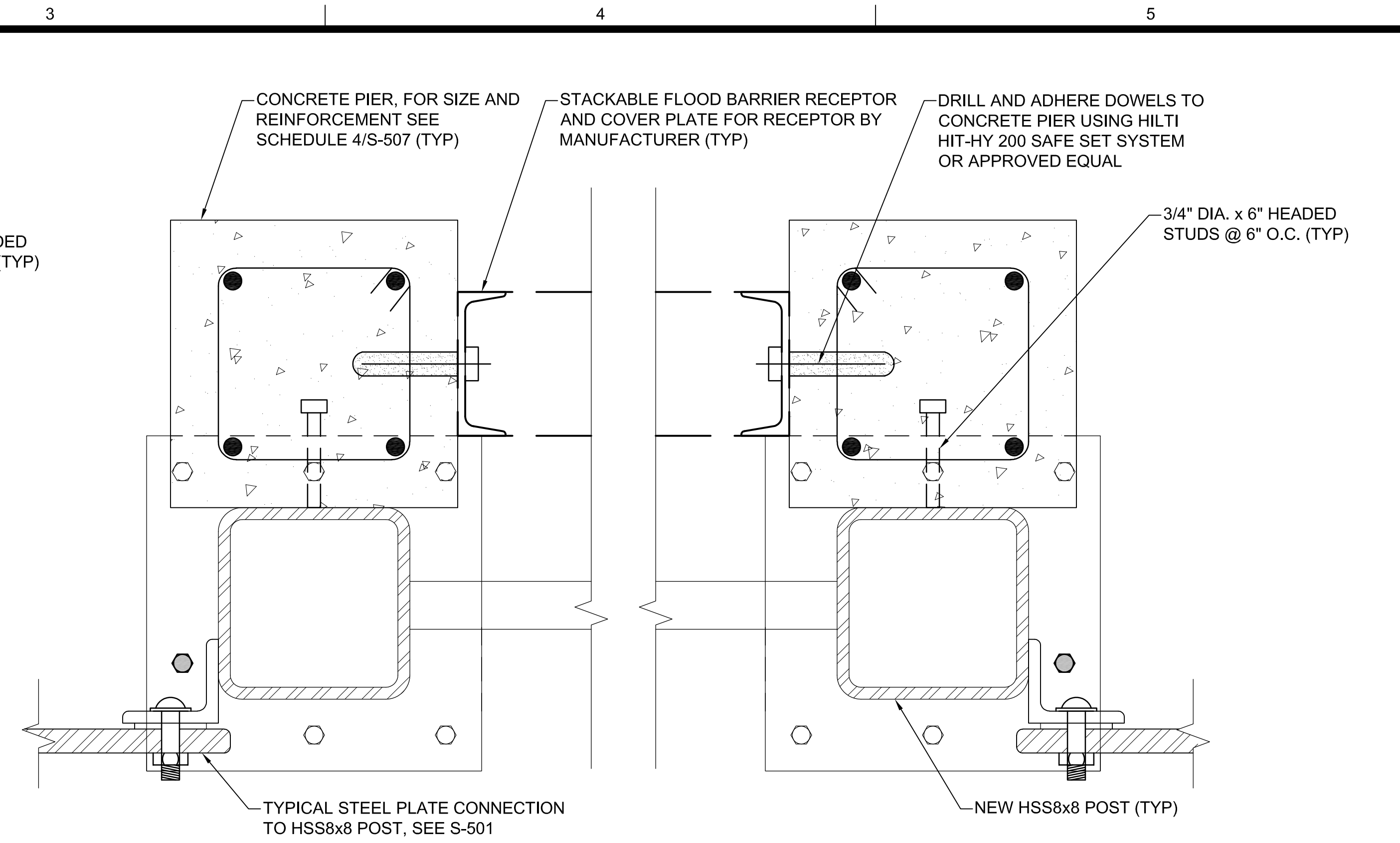

2 MURRAY STREET PEDESTRIAN GATE PLAN DETAIL
 S-507 3"=1'-0" 0 3" 6" 9"

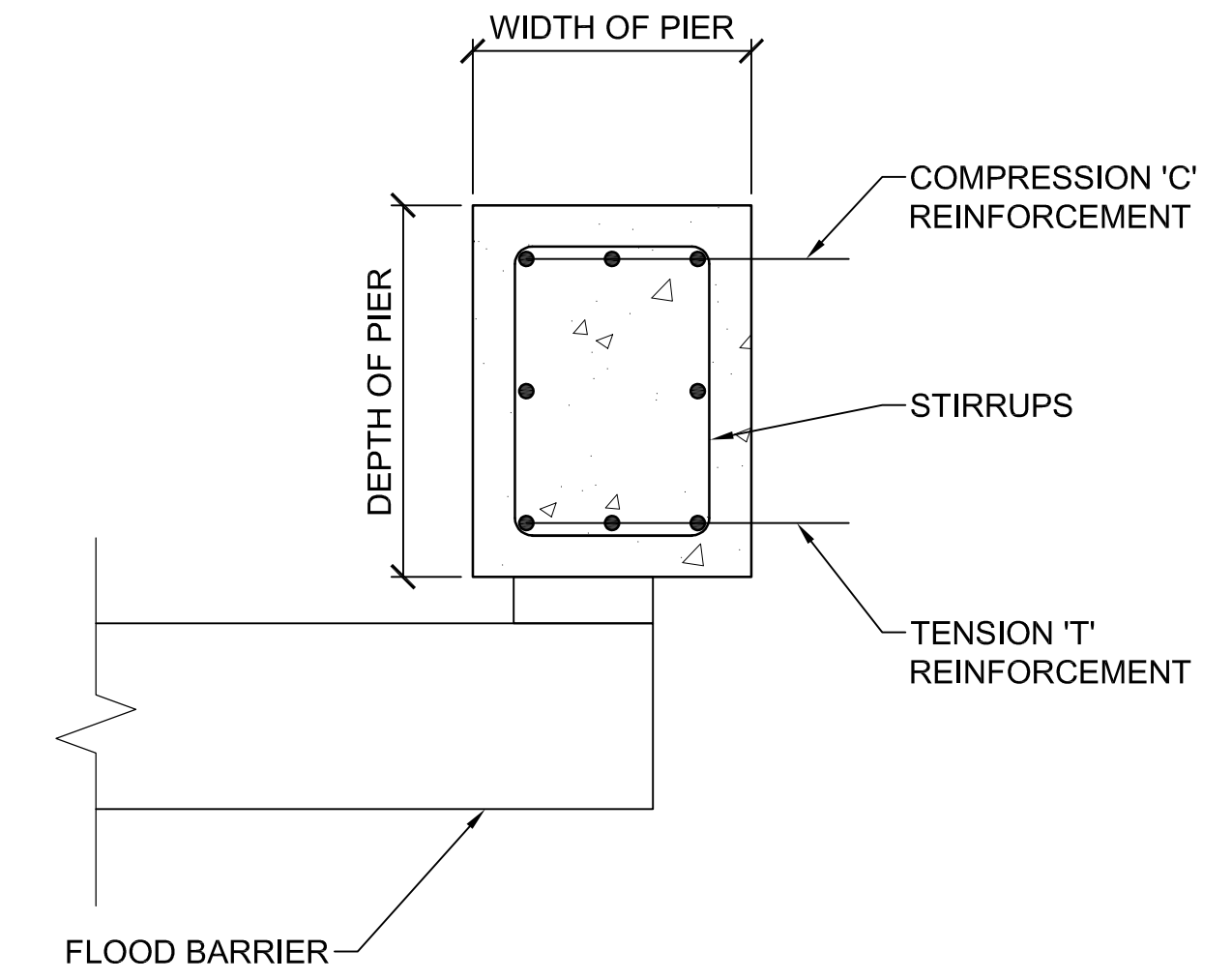

PIER SCHEDULE					
LOCATION	DIMENSIONS		REINFORCEMENT		
	WIDTH	DEPTH	REINF 'T'	REINF 'C'	STIRRUPS
MURRAY PEDESTRIAN EAST	8	8	2#5	2#5	2 LEGS #4@8"
MURRAY PEDESTRIAN WEST	8	8	2#5	2#5	2 LEGS #4@8"
WARREN PEDESTRIAN EAST	12	10	2#6	2#6	2 LEGS #4@8"
WARREN PEDESTRIAN WEST	12	12	2#6	2#6	2 LEGS #4@8"

4 CONCRETE PIER SCHEDULE
 S-507 1 1/2"=1'-0" 0 1' 1'6"

MARK	DATE	DESCRIPTION	BY
A	11/01/19	ISSUED FOR BID- 95%	AC

PROJECT NO.:	3019666
DESIGNED BY:	N. TOLLI
DRAWN BY:	N. TOLLI
CHECKED BY:	A. CERINO P.E.
APPROVED BY:	A. CERINO P.E.
COPYRIGHT:	STV, INC

MARK	DATE	DESCRIPTION	BY
A	11/01/19	ISSUED FOR BID- 95%	AC

PROJECT NO.:	3019666
DESIGNED BY:	N. TOLLI
DRAWN BY:	N. TOLLI
CHECKED BY:	A. CERINO P.E.
APPROVED BY:	A. CERINO P.E.
COPYRIGHT:	STV, INC

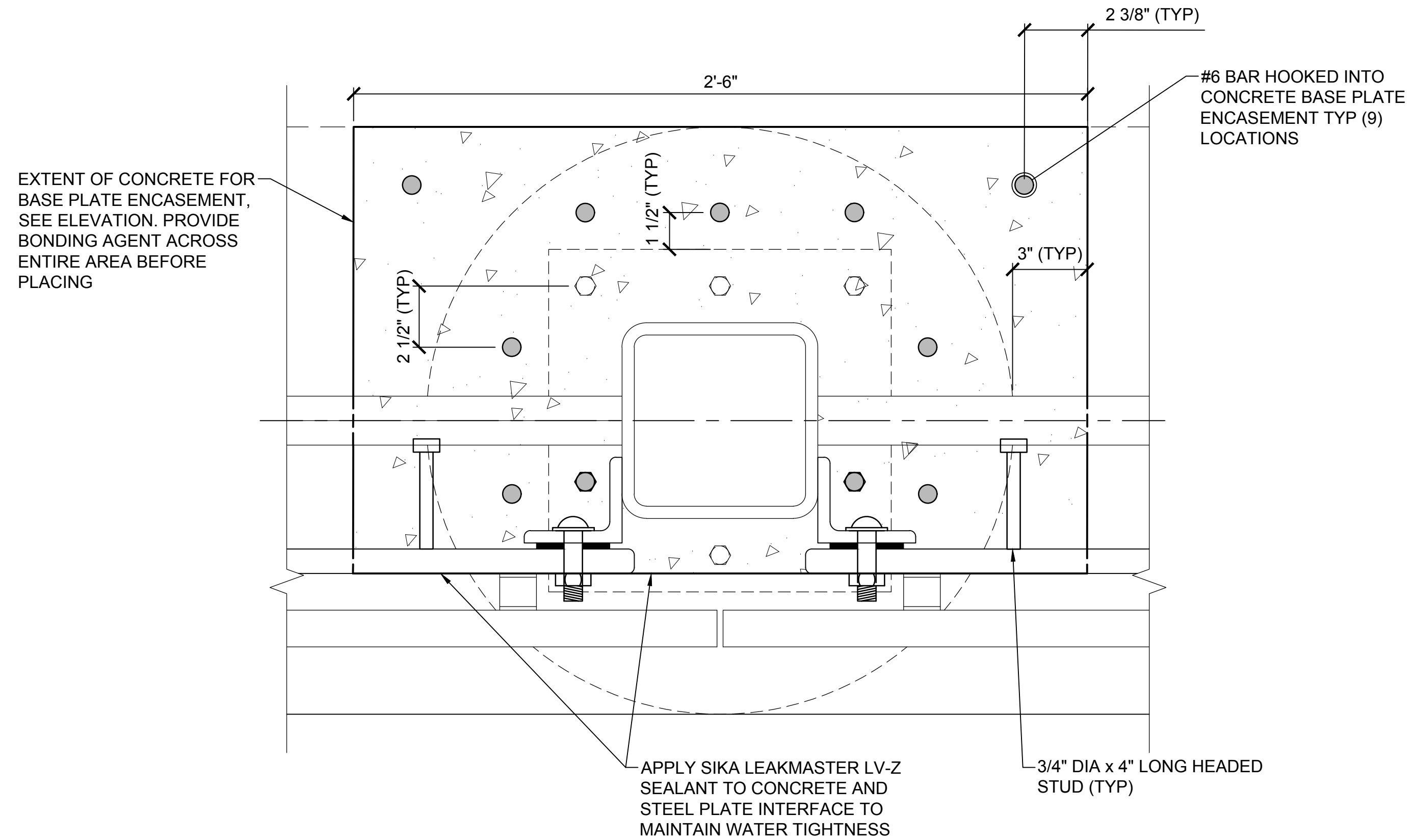

1 BASE PLATE ENCASEMENT PLAN DETAIL
S-508 3"=1'-0" 0 3" 6" 9"

- NOTES:
- REFER TO S-501 FOR ALL ADDITIONAL INFORMATION NOT SHOWN.
 - DETAIL TO BE USED WHEN TOP OF GRADE BEAM DOES NOT PROVIDE A MINIMUM OF 4" OF CONCRETE ABOVE TOP OF EXISTING FENCE BASE PLATE.

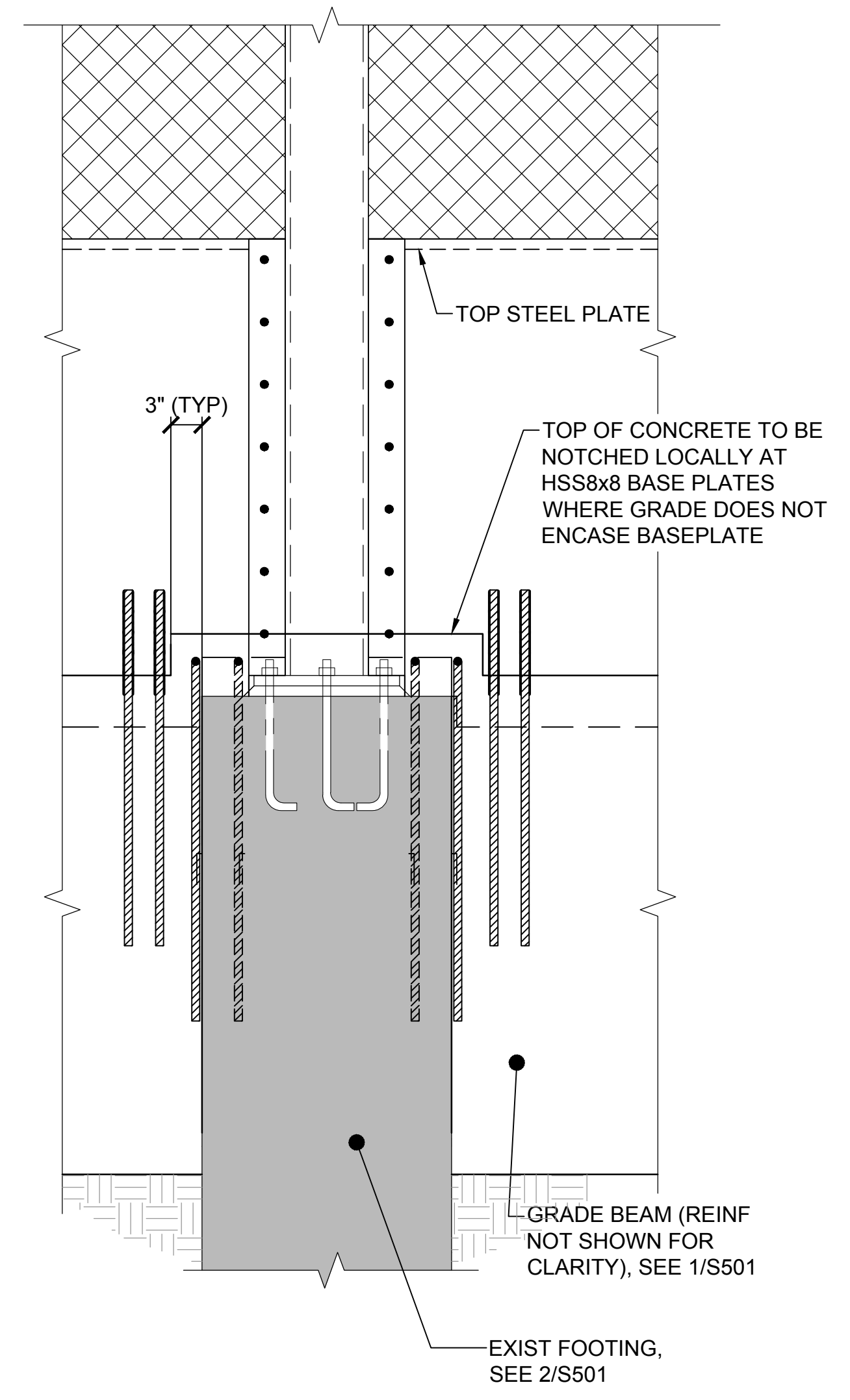

2 BASE PLATE ENCASEMENT ELEVATION
S-508 1"=1'-0" 0 1' 2'

- NOTES:
- REFER TO S-501 FOR ALL ADDITIONAL INFORMATION NOT SHOWN.
 - DETAIL TO BE USED WHEN TOP OF GRADE BEAM DOES NOT PROVIDE A MINIMUM OF 4" OF CONCRETE ABOVE TOP OF EXISTING FENCE BASE PLATE.

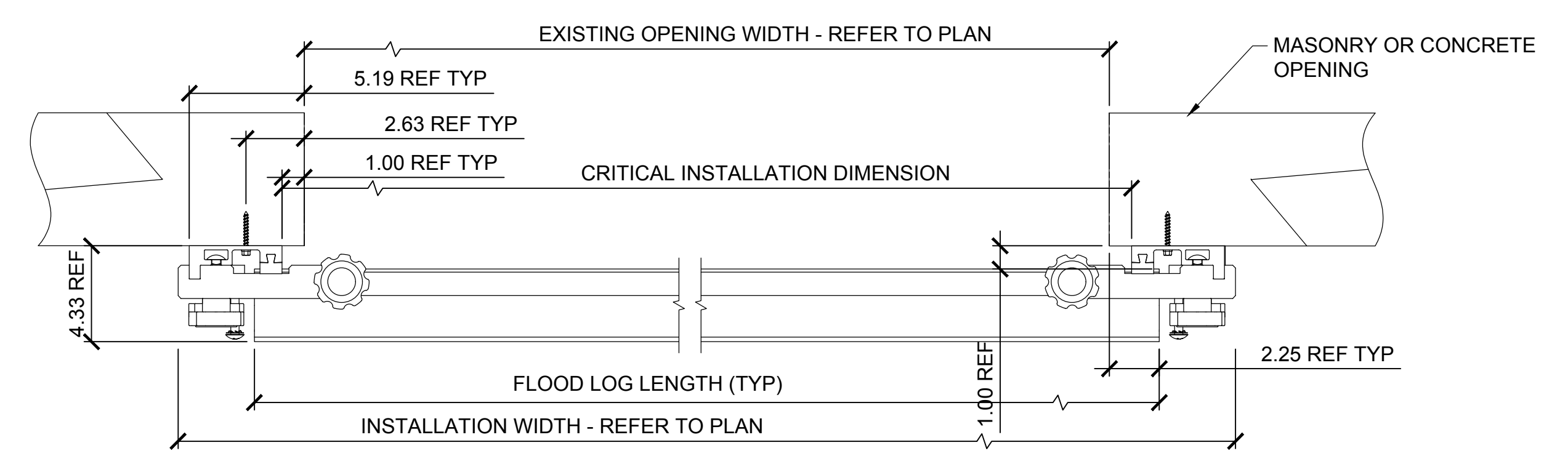

1 WATERSIDE PLAN DETAIL
 S-510 NOT TO SCALE

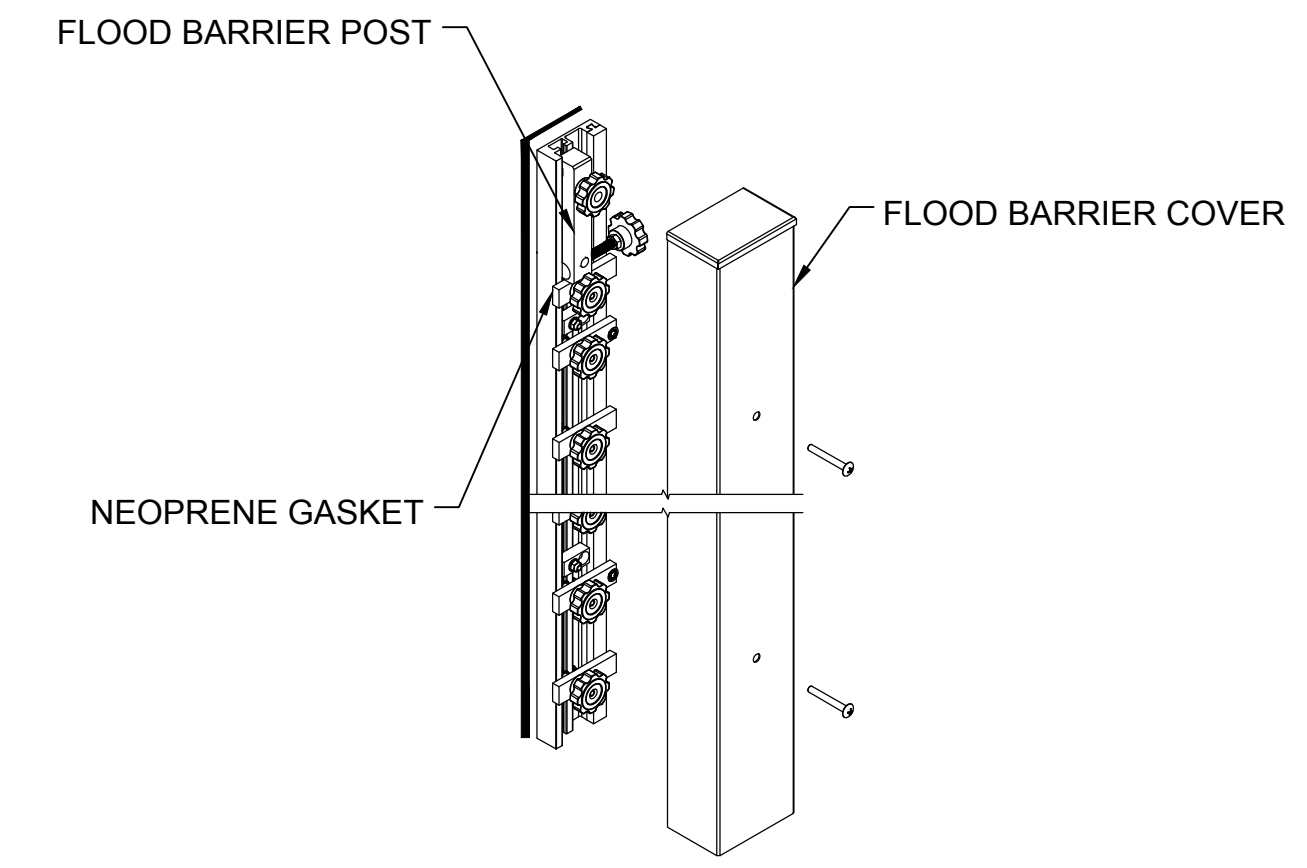

2 COVER DETAIL
 S-510 NOT TO SCALE

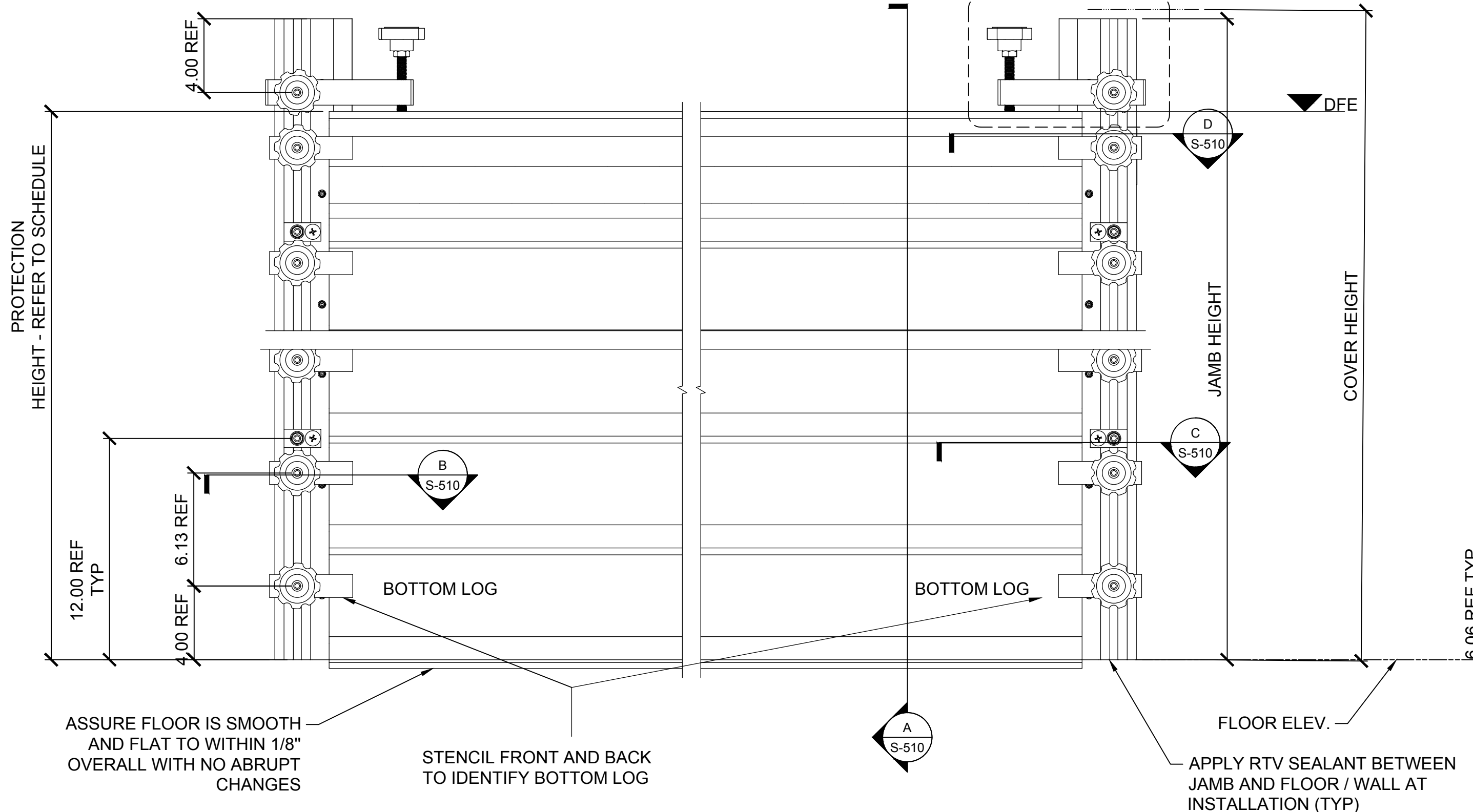

3 ELEVATION DETAIL
 S-510 NOT TO SCALE

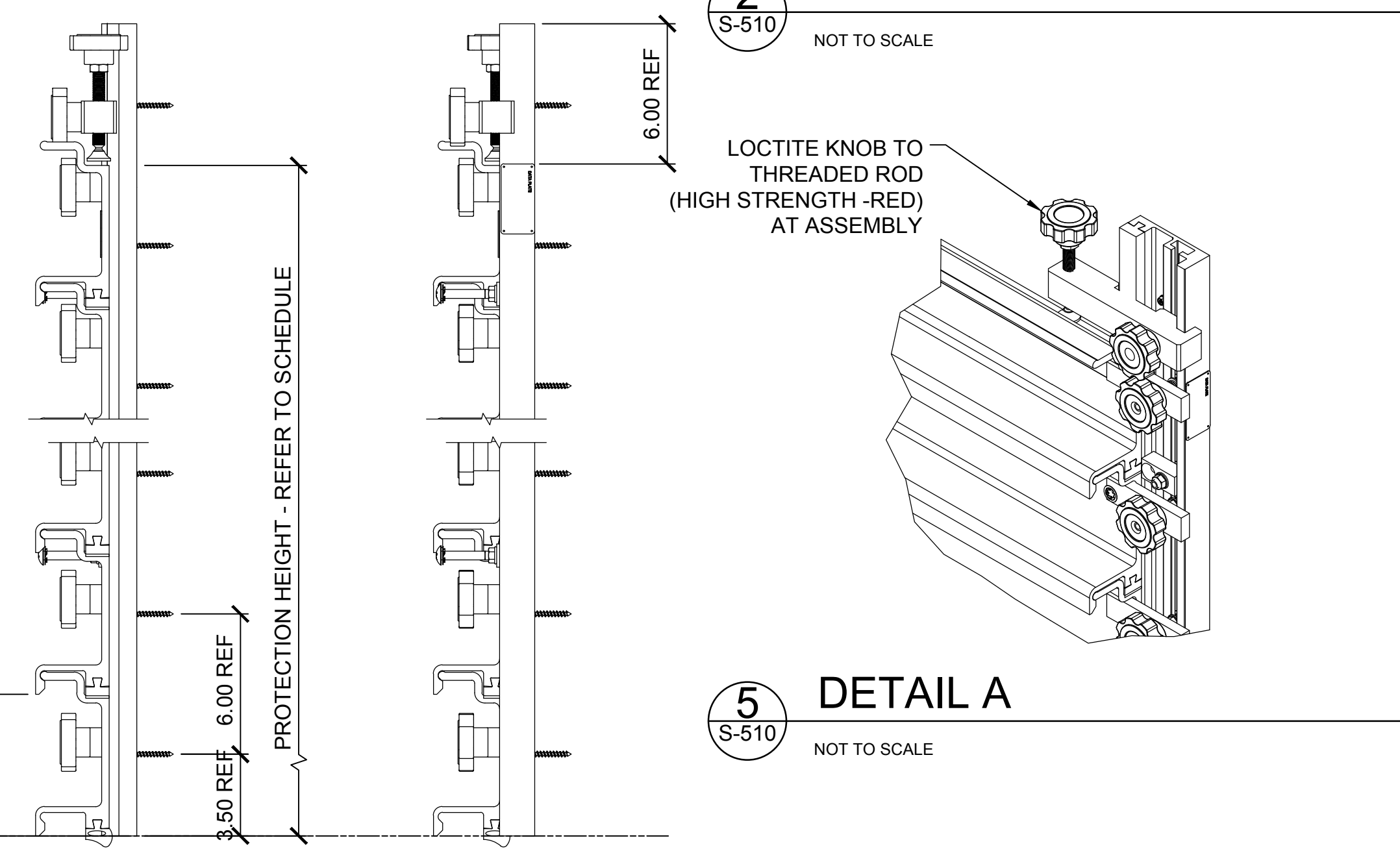

4 SECTION B-B
 S-510 NOT TO SCALE

ALL FLOOD BARRIER DETAILS SHOWN ON THIS SHEET ARE PROVIDED TO THE CONTRACTOR FOR BIDDING PURPOSES. THE FINAL DESIGN, LAYOUT AND COORDINATION OF THE BARRIER IS BY THE CONTRACTOR AND THE FLOOD BARRIER MANUFACTURER. CONTRACTOR'S ENGINEER IS RESPONSIBLE TO SUBMIT SIGNED & SEALED CALCULATIONS FOR THE FLOOD BARRIER.

NOTES:

1. DETAILS ARE BASED ON DEVICES BY PRESRAY CORP. WASSAIC, NEW YORK.
2. DIMENSIONS SHOWN AND LISTED AS "REF" ARE IN INCHES AND WILL BE DETERMINED BY MANUFACTURER IN THE SHOP DRAWINGS PROCESS FOR PROJECT SPECIFIC LOCATIONS.
3. SEALED SURFACES MUST BE SMOOTH WITHOUT DEVIATIONS OF GREATER THAN 0.015" AND FREE OF CRACKS.
4. CONTRACTOR SHALL FOLLOW MANUFACTURER RECOMMENDATION FOR INSTALLATION.

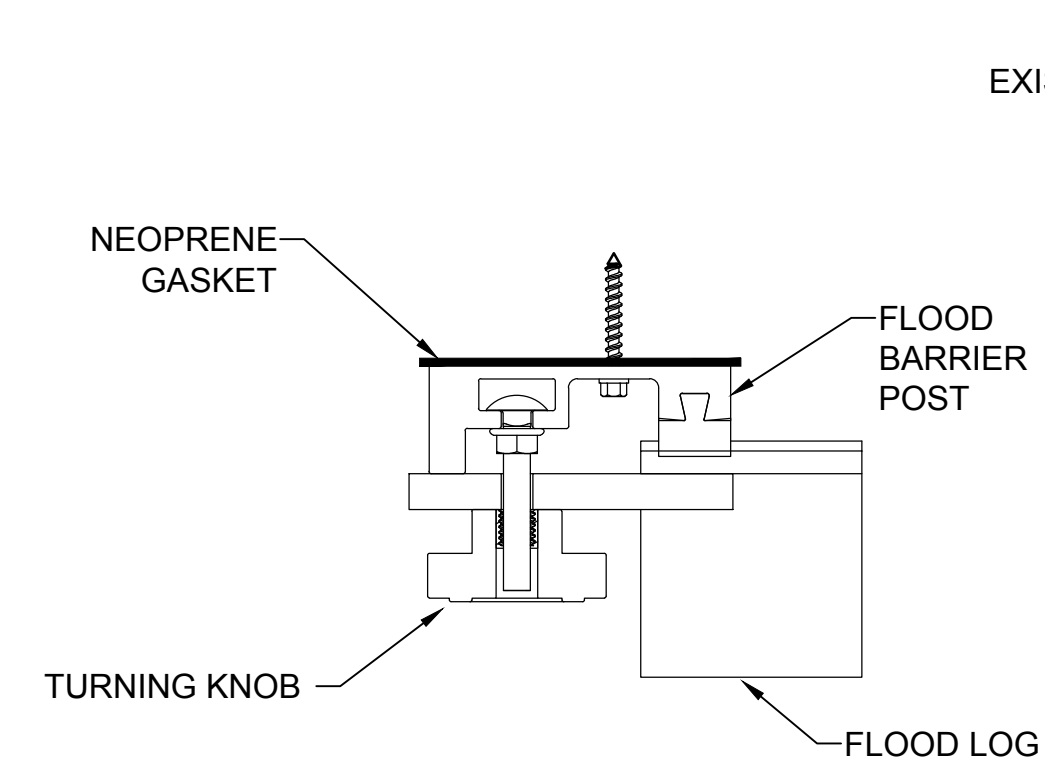

6 DETAIL D-D
 S-510 NOT TO SCALE

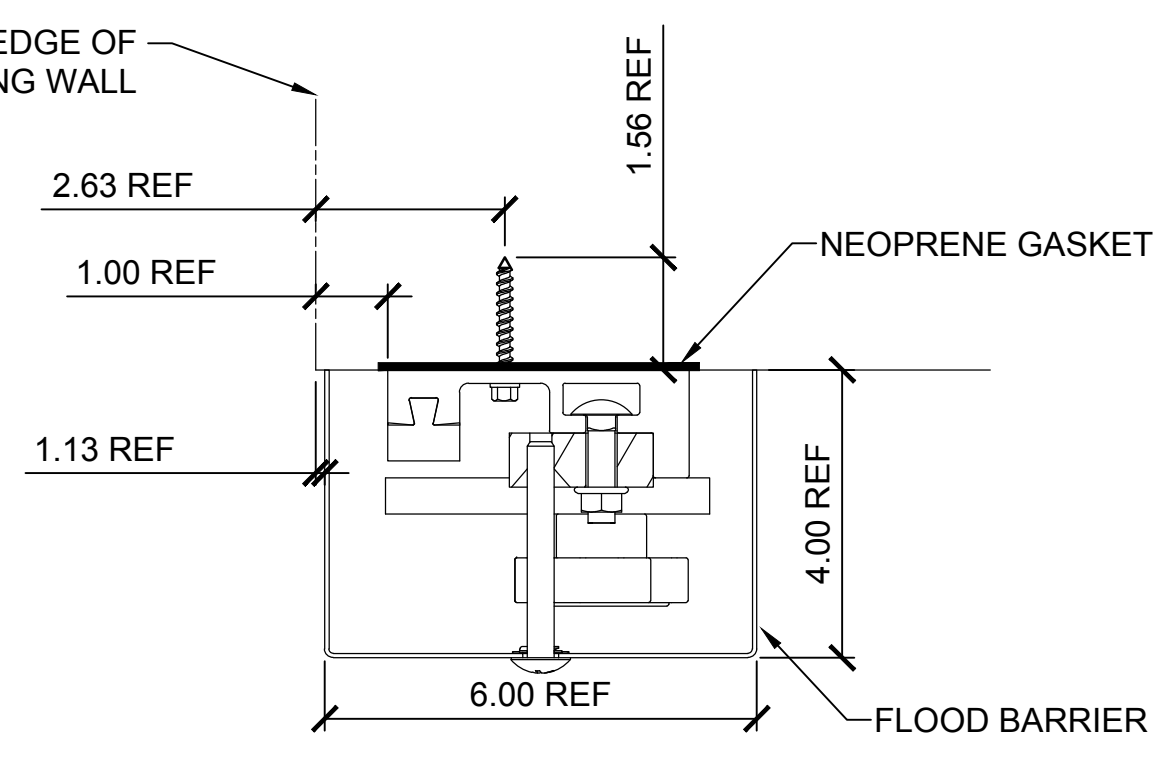

7 DETAIL C-C
 S-510 NOT TO SCALE

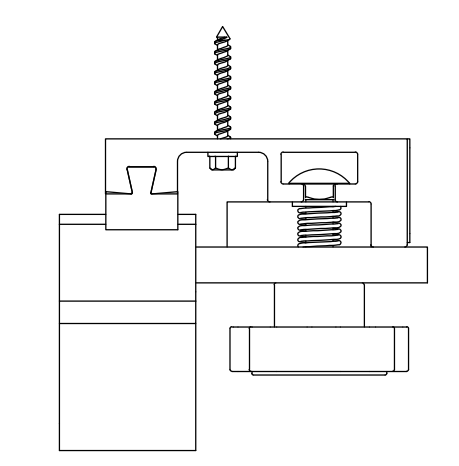

8 DETAIL E-E
 S-510 NOT TO SCALE

SEALS

PROJECT IDENTIFICATION

NEW YORK STATE OF OPPORTUNITY
Battery Park City Authority
 BATTERY PARK CITY
 BALLFIELD AND COMMUNITY CENTER

MARK	DATE	DESCRIPTION	BY
A	11/01/19	ISSUED FOR BID - 95%	AC

ISSUE BLOCK

PROJECT NO.:	3019666
DESIGNED BY:	N. TOLLI
DRAWN BY:	N. TOLLI
CHECKED BY:	A. CERINO, P.E.
APPROVED BY:	A. CERINO, P.E.
COPYRIGHT:	STV, INC

SHEET TITLE

STACKABLE FLOOD BARRIER REFERENCE DETAILS SHEET 1 OF 4

S-510

- NOTES:**
1. DETAILS ARE BASED ON DEVICES BY PRESRAY CORP. WASSAIC, NEW YORK.
 2. DIMENSIONS SHOWN AND LISTED AS "REF" ARE IN INCHES AND WILL BE DETERMINED BY MANUFACTURER IN THE SHOP DRAWINGS PROCESS FOR PROJECT SPECIFIC LOCATIONS.
 3. SEALED SURFACES MUST BE SMOOTH WITHOUT DEVIATIONS OF GREATER THAN 0.015" AND FREE OF CRACKS.
 4. CONTRACTOR SHALL FOLLOW MANUFACTURER RECOMMENDATION FOR INSTALLATION.

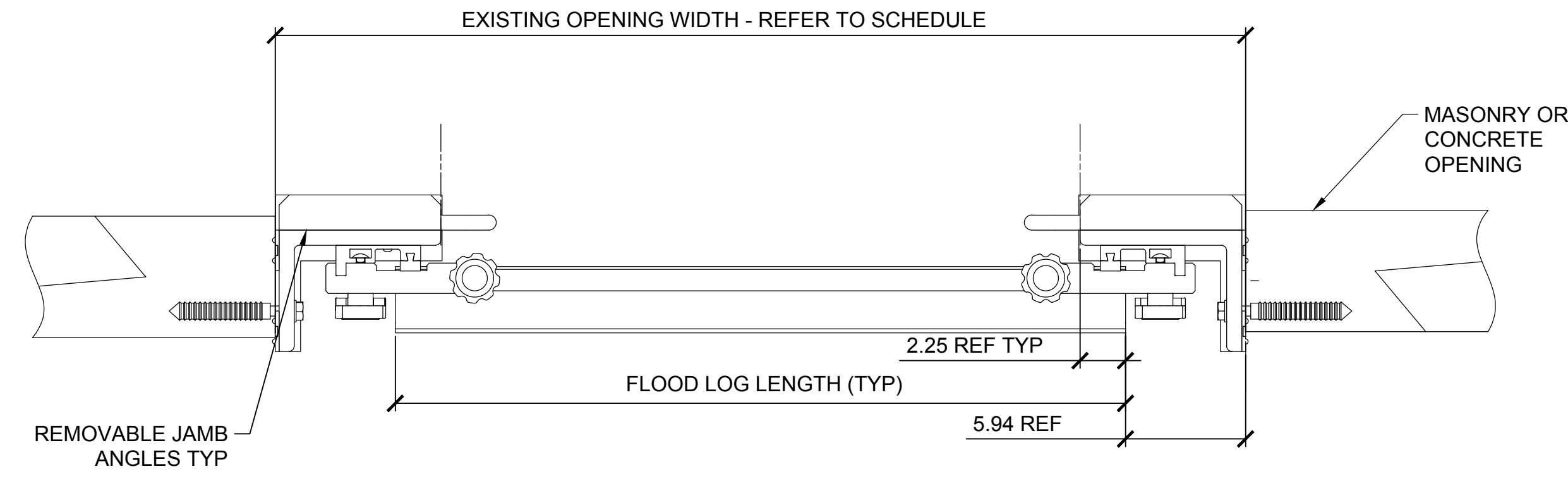

1 WATERSIDE PLAN DETAIL
 S-511 NOT TO SCALE

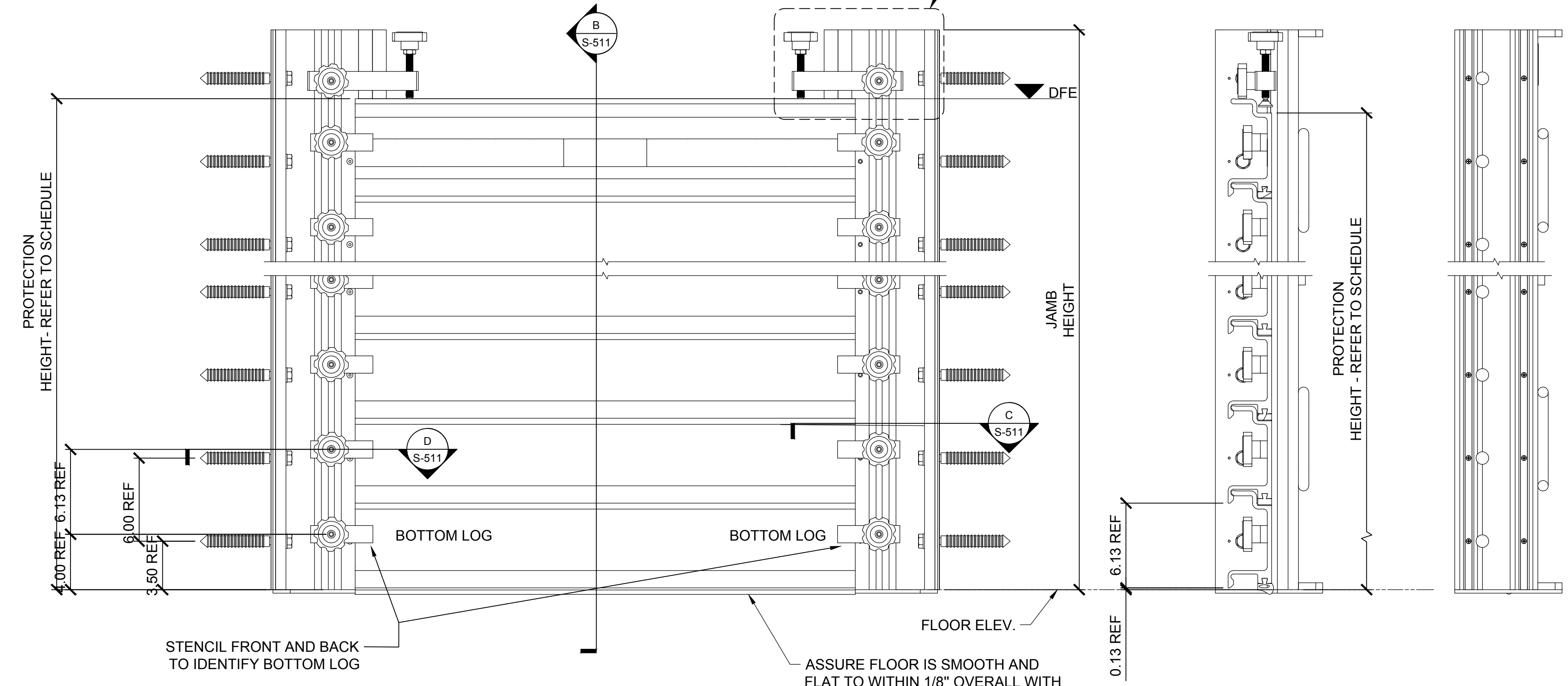

2 ELEVATION DETAIL
 S-511 NOT TO SCALE

3 SECTION B-B
 S-511 NOT TO SCALE

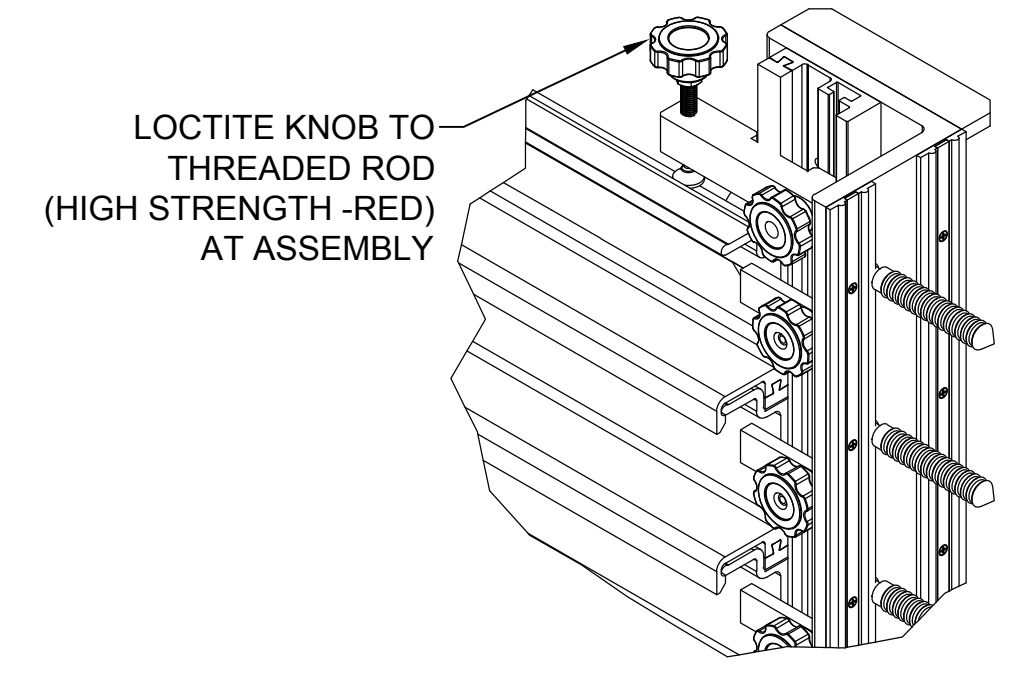

4 DETAIL A
 S-511 NOT TO SCALE

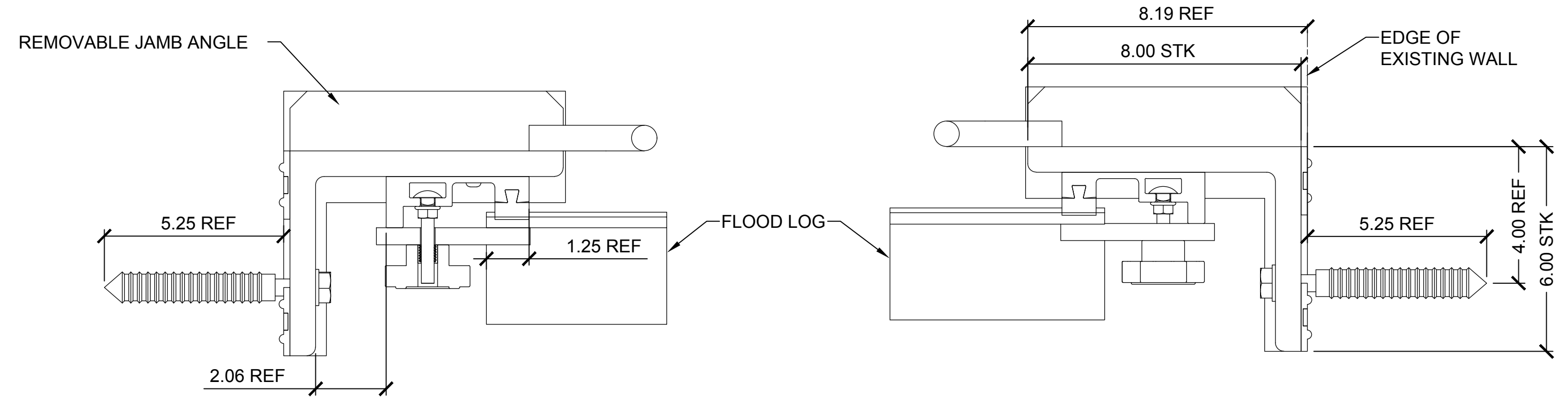

5 SECTION D-D
 S-511 NOT TO SCALE

6 SECTION C-C
 S-511 NOT TO SCALE

ALL FLOOD BARRIER DETAILS SHOWN ON THIS SHEET ARE PROVIDED TO THE CONTRACTOR FOR BIDDING PURPOSES. THE FINAL DESIGN, LAYOUT AND COORDINATION OF THE BARRIER IS BY THE CONTRACTOR AND THE FLOOD BARRIER MANUFACTURER. CONTRACTOR'S ENGINEER IS RESPONSIBLE TO SUBMIT SIGNED & SEALED CALCULATIONS FOR THE FLOOD BARRIER.

SEALS

PROJECT IDENTIFICATION
 NEW YORK STATE OF OPPORTUNITY
Battery Park City Authority
 BATTERY PARK CITY BALLFIELD AND COMMUNITY CENTER

MARK	DATE	DESCRIPTION	BY
A	11/01/19	ISSUED FOR BID - 95%	AC

ISSUE BLOCK

PROJECT NO.:	3019666
DESIGNED BY:	N. TOLLI
DRAWN BY:	N. TOLLI
CHECKED BY:	A. CERINO, P.E.
APPROVED BY:	A. CERINO, P.E.
COPYRIGHT:	STV, INC

SHEET TITLE
STACKABLE FLOOD BARRIER REFERENCE DETAILS SHEET 2 OF 4

S-511

NOTES:

1. DETAILS ARE BASED ON DEVICES BY PRESRAY CORP.
2. WALL MOUNT COULD BE FACE, JAMB OR A COMBINATION OF BOTH.
3. DIMENSIONS SHOWN AND LISTED AS "REF" ARE IN INCHES AND WILL BE DETERMINED BY MANUFACTURER IN THE SHOP DRAWINGS PROCESS FOR PROJECT SPECIFIC LOCATIONS.
4. SEALED SURFACES MUST BE SMOOTH WITHOUT DEVIATIONS OF GREATER THAN 0.015" AND FREE OF CRACKS.
5. CONTRACTOR SHALL FOLLOW MANUFACTURER RECOMMENDATION FOR INSTALLATION.
6. THE CONTRACTOR SHALL PROVIDE SHOP DRAWINGS FROM DEPLOYABLE FLOOD BARRIER MANUFACTURE WHICH SHALL BE SIGNED AND SEALED BY NYS PROFESSIONAL STRUCTURAL ENGINEER.
7. DEPLOYABLE FLOOD BARRIER CENTER MULLIONS MAY BE INSTALLED IN SLOPED SURFACE. CONTRACTOR TO PROVIDE EXISTING GRADE/SLOPE TO MANUFACTURE FOR SHOP DRAWINGS.
8. NUMBER OF DEPLOYABLE FLOOD BARRIER CENTER MULLIONS MAY VARY PER MANUFACTURE SHOP DRAWINGS AND RECOMMENDATIONS.

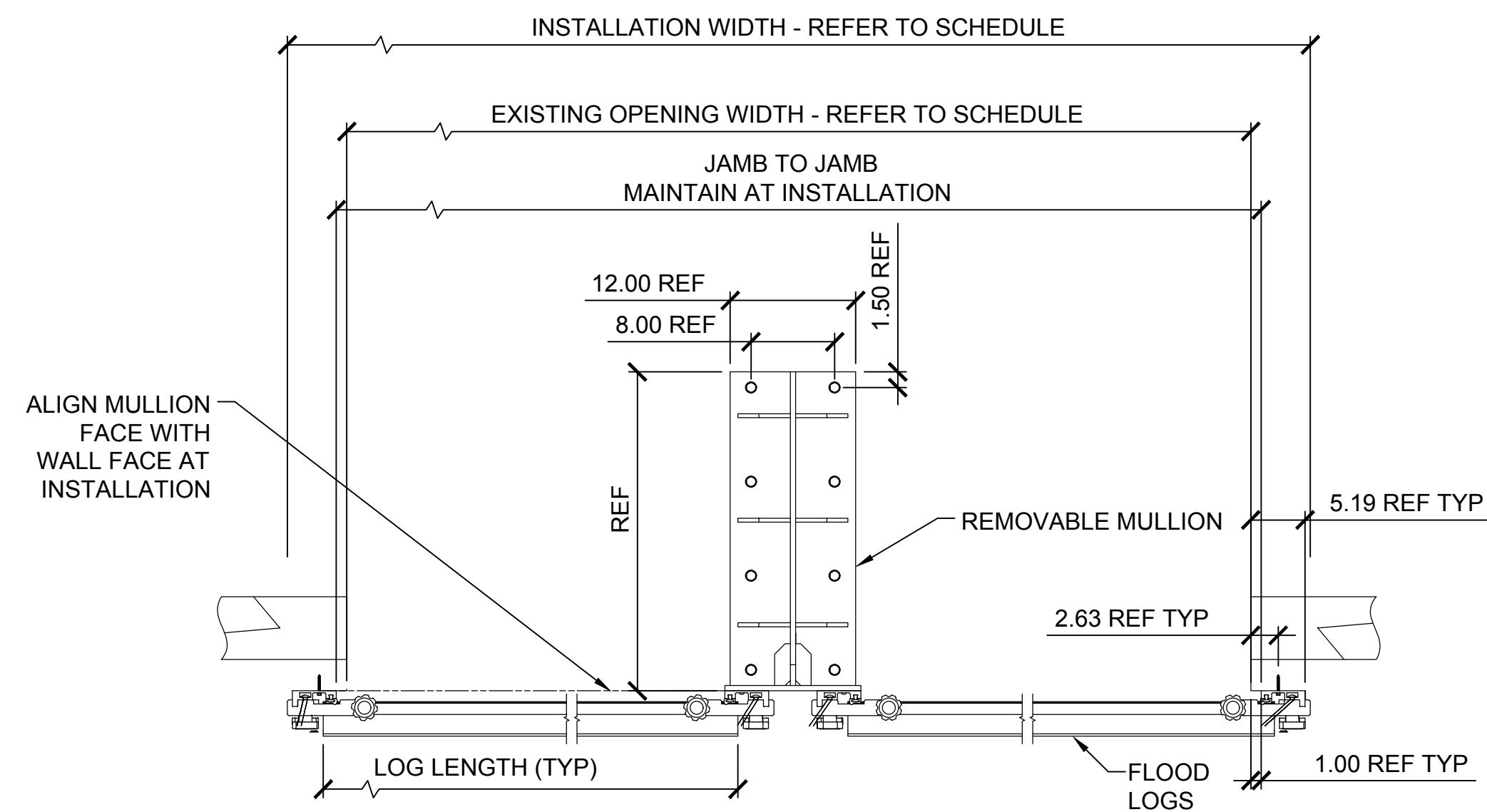

1 WATERSIDE PLAN DETAIL
 S-512 NOT TO SCALE

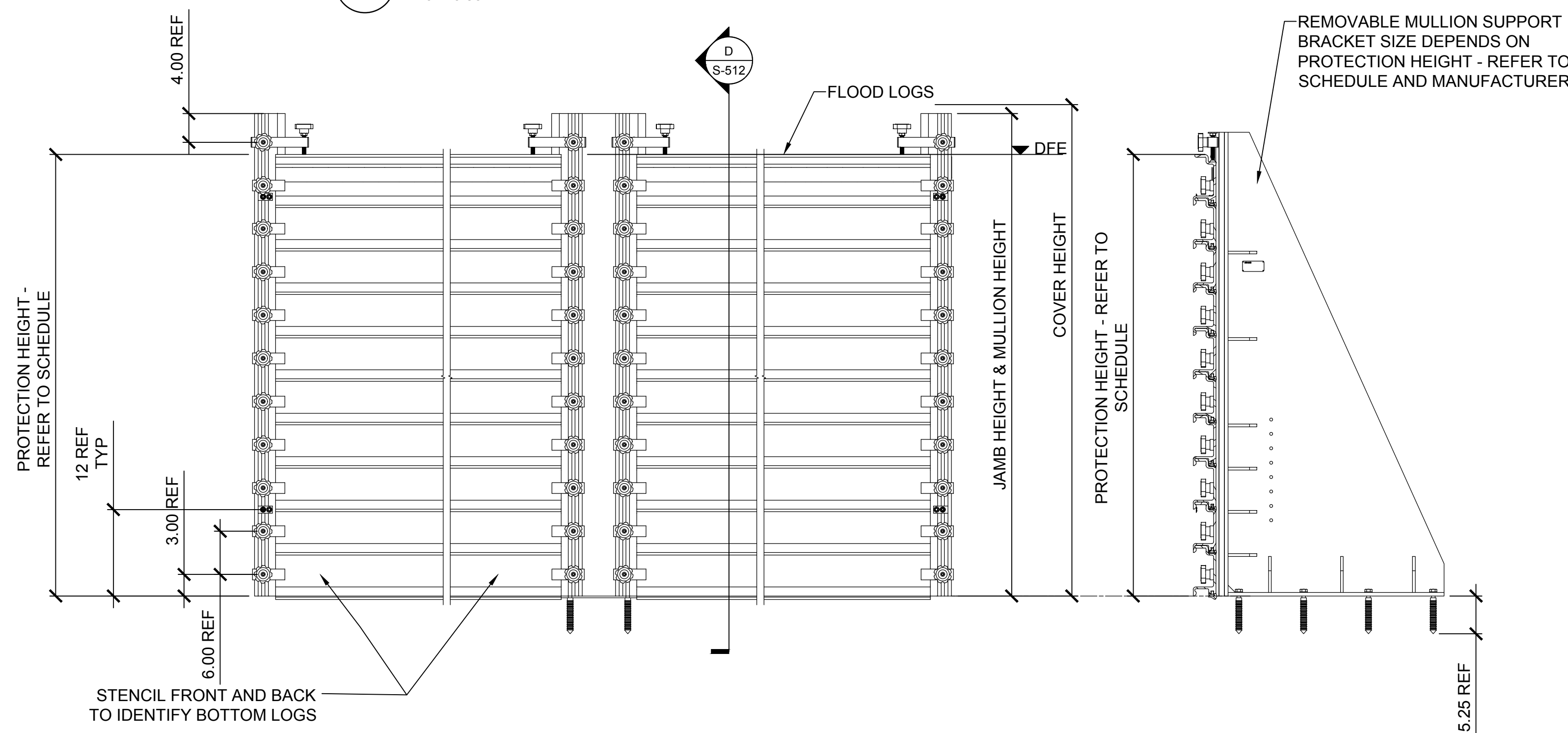

2 ELEVATION DETAIL
 S-512 NOT TO SCALE

3 SECTION D-D
 S-512 NOT TO SCALE

ALL FLOOD BARRIER DETAILS SHOWN ON THIS SHEET ARE PROVIDED TO THE CONTRACTOR FOR BIDDING PURPOSES. THE FINAL DESIGN, LAYOUT AND COORDINATION OF THE BARRIER IS BY THE CONTRACTOR AND THE FLOOD BARRIER MANUFACTURER. CONTRACTOR'S ENGINEER IS RESPONSIBLE TO SUBMIT SIGNED & SEALED CALCULATIONS FOR THE FLOOD BARRIER.

SEALS

PROJECT IDENTIFICATION

NEW YORK STATE OF OPPORTUNITY
Battery Park City Authority
 BATTERY PARK CITY
 BALLFIELD AND COMMUNITY
 CENTER

MARK	DATE	DESCRIPTION	BY
A	11/01/19	ISSUED FOR BID- 95%	AC

ISSUE BLOCK

PROJECT NO.:	3019666
DESIGNED BY:	N. TOLLI
DRAWN BY:	N. TOLLI
CHECKED BY:	A. CERINO, P.E.
APPROVED BY:	A. CERINO, P.E.
COPYRIGHT:	STV, INC

SHEET TITLE

STACKABLE FLOOD
 BARRIER REFERENCE
 DETAILS SHEET 3 OF 4

MARK	DATE	DESCRIPTION	BY
A	11/01/19	ISSUED FOR BID- 95%	AC

ISSUE BLOCK

PROJECT NO.:	3019666
DESIGNED BY:	N. TOLLI
DRAWN BY:	N. TOLLI
CHECKED BY:	A. CERINO, P.E.
APPROVED BY:	A. CERINO, P.E.
COPYRIGHT:	STV, INC

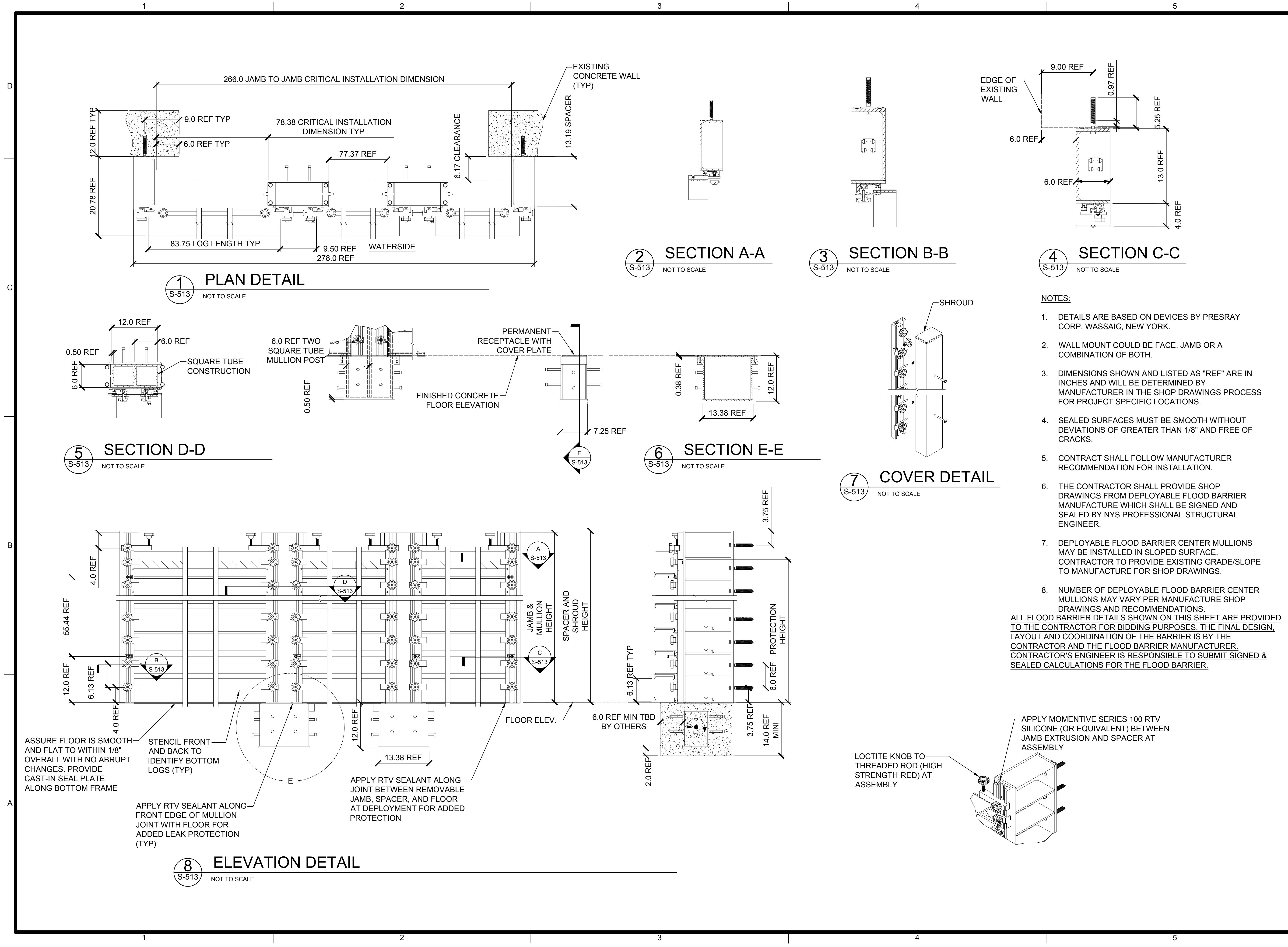

- NOTES:**
1. DETAILS ARE BASED ON DEVICES BY PRESRAY CORP. WASSAIC, NEW YORK.
 2. WALL MOUNT COULD BE FACE, JAMB OR A COMBINATION OF BOTH.
 3. DIMENSIONS SHOWN AND LISTED AS "REF" ARE IN INCHES AND WILL BE DETERMINED BY MANUFACTURER IN THE SHOP DRAWINGS PROCESS FOR PROJECT SPECIFIC LOCATIONS.
 4. SEALED SURFACES MUST BE SMOOTH WITHOUT DEVIATIONS OF GREATER THAN 1/8" AND FREE OF CRACKS.
 5. CONTRACT SHALL FOLLOW MANUFACTURER RECOMMENDATION FOR INSTALLATION.
 6. THE CONTRACTOR SHALL PROVIDE SHOP DRAWINGS FROM DEPLOYABLE FLOOD BARRIER MANUFACTURE WHICH SHALL BE SIGNED AND SEALED BY NYS PROFESSIONAL STRUCTURAL ENGINEER.
 7. DEPLOYABLE FLOOD BARRIER CENTER MULLIONS MAY BE INSTALLED IN SLOPED SURFACE. CONTRACTOR TO PROVIDE EXISTING GRADE/SLOPE TO MANUFACTURE FOR SHOP DRAWINGS.
 8. NUMBER OF DEPLOYABLE FLOOD BARRIER CENTER MULLIONS MAY VARY PER MANUFACTURE SHOP DRAWINGS AND RECOMMENDATIONS.
- ALL FLOOD BARRIER DETAILS SHOWN ON THIS SHEET ARE PROVIDED TO THE CONTRACTOR FOR BIDDING PURPOSES. THE FINAL DESIGN, LAYOUT AND COORDINATION OF THE BARRIER IS BY THE CONTRACTOR AND THE FLOOD BARRIER MANUFACTURER. CONTRACTOR'S ENGINEER IS RESPONSIBLE TO SUBMIT SIGNED & SEALED CALCULATIONS FOR THE FLOOD BARRIER.

SECTION 00 0010 - TABLE OF CONTENTS

SECT. NO.	SECTION TITLE	REMARKS
00 0000	Cover	
00 0010	Table Of Contents	
DIVISION 00	PROCUREMENT AND CONTRACTING REQUIREMENTS	
DIVISION 01	GENERAL REQUIREMENTS	
015639	Temporary Tree And Plant Protection	
DIVISION 02	EXISTING CONDITIONS	
021000	General Demolition	
DIVISION 03	CONCRETE	
031000	Concrete Formwork	
032000	Concrete Reinforcement	
033000	Cast-in-Place Concrete	
DIVISION 05 - METALS		
051200	Structural Steel	
DIVISION 08	OPENINGS	
083919	Flood Panels And Barriers	
DIVISION 09	FINISHES	
099113	Exterior Painting	
DIVISION 31 - EARTHWORK		
311000	Site Clearing	
311500	Excavation Support And Protection	
312000	Earthwork Moving	
312319	Dewatering	

SECT. NO.	SECTION TITLE	REMARKS
DIVISION 32	EXTERIOR IMPROVEMENTS	
323120	Decorative Metal Panels	
329113	Soil Preparation	
32 9300	Plants	

END OF SECTION 00 0010

SECTION 015639 - TEMPORARY TREE AND PLANT PROTECTION

PART 1 - GENERAL

1.1 RELATED DOCUMENTS

- A. Drawings and general provisions of the Contract, including General and Supplementary Conditions and Division 01 Specification Sections, apply to this Section.

1.2 SUMMARY

- A. Section includes general protection and pruning of existing trees and plants that are affected by execution of the Work, whether temporary or permanent construction.
- B. Related Requirements:
 - 1. Division 01 "Temporary Facilities and Controls" for temporary site fencing.
 - 2. Section 311000 "Site Clearing" for removing existing trees and shrubs.

1.3 DEFINITIONS

- A. Caliper: Diameter of a trunk measured by a diameter tape or the average of the smallest and largest diameters at a height 6 inches above the ground for trees up to and including 4-inch size at this height and as measured at a height of 12 inches above the ground for trees larger than 4-inch size.
- B. Caliper (DBH): Diameter breast height; diameter of a trunk as measured by a diameter tape or the average of the smallest and largest diameters at a height 54 inches above the ground line for trees with caliper of 8 inches or greater as measured at a height of 12 inches above the ground.
- C. Plant-Protection Zone: Area surrounding individual trees, groups of trees, shrubs, or other vegetation to be protected during construction and indicated on Drawings.
- D. Tree-Protection Zone: Area surrounding individual trees or groups of trees to be protected during construction and defined by a circle concentric with each tree with a radius 12 times the tree's caliper size and with a minimum radius of 96 inches unless otherwise indicated .
- E. Vegetation: Trees, shrubs, groundcovers, grass, and other plants.

1.4 PREINSTALLATION MEETINGS

- A. Preinstallation Conference: Conduct conference at Project site .
 - 1. Review methods and procedures related to temporary tree and plant protection including, but not limited to, the following:
 - a. Tree-service firm's personnel, and equipment needed to make progress and avoid delays.

- b. Arborist's responsibilities.
- c. Quality-control program.
- d. Coordination of Work and equipment movement with the locations of protection zones.
- e. Trenching by hand or with air spade within protection zones.
- f. Field quality control.

1.5 ACTION SUBMITTALS

- A. Product Data: For each type of product.
- B. Shop Drawings:
 1. Include plans, elevations, sections, and locations of protection-zone fencing and signage, showing relation of equipment-movement routes and material storage locations with protection zones.
 2. Detail fabrication and assembly of protection-zone fencing and signage.
 3. Indicate extent of trenching by hand or with air spade within protection zones.
- C. Tree Pruning Schedule: Written schedule detailing scope and extent of pruning of trees to remain that interfere with or are affected by construction.
 1. Species and size of tree.
 2. Location on site plan. Include unique identifier for each.
 3. Reason for pruning.
 4. Description of pruning to be performed.
 5. Description of maintenance following pruning.

1.6 INFORMATIONAL SUBMITTALS

- A. Qualification Data: For arborist and tree service firm.
- B. Certification: From arborist, certifying that trees indicated to remain have been protected during construction according to recognized standards and that trees were promptly and properly treated and repaired when damaged.
- C. Maintenance Recommendations: From arborist, for care and protection of trees affected by construction during and after completing the Work.
- D. Existing Conditions: Documentation of existing trees and plantings indicated to remain, which establishes preconstruction conditions that might be misconstrued as damage caused by construction activities.
 1. Use sufficiently detailed photographs or video recordings.
 2. Include plans and notations to indicate specific wounds and damage conditions of each tree or other plants designated to remain.
- E. Quality-control program.

1.7 QUALITY ASSURANCE

- A. Arborist Qualifications: Certified Arborist as certified by ISA .
- B. Tree Service Firm Qualifications: An experienced tree service firm that has successfully completed temporary tree and plant protection work similar to that required for this Project and that will assign an experienced, qualified arborist to Project site during execution of the Work.
- C. Quality-Control Program: Prepare a written program to systematically demonstrate the ability of personnel to properly follow procedures and handle materials and equipment during the Work without damaging trees and plantings. Include dimensioned diagrams for placement of protection zone fencing and signage, the arborist's and tree-service firm's responsibilities, instructions given to workers on the use and care of protection zones, and enforcement of requirements for protection zones.

1.8 FIELD CONDITIONS

- A. The following practices are prohibited within protection zones:
 - 1. Storage of construction materials, debris, or excavated material.
 - 2. Moving or parking vehicles or equipment.
 - 3. Foot traffic.
 - 4. Erection of sheds or structures.
 - 5. Impoundment of water.
 - 6. Excavation or other digging unless otherwise indicated.
 - 7. Attachment of signs to or wrapping materials around trees or plants unless otherwise indicated.
- B. Do not direct vehicle or equipment exhaust toward protection zones.
- C. Prohibit heat sources, flames, ignition sources, and smoking within or near protection zones and organic mulch.

PART 2 - PRODUCTS

2.1 MATERIALS

- A. Backfill Soil: Stockpiled soil mixed with planting soil or Planting soil of suitable moisture content and granular texture for placing around tree; free of stones, roots, plants, sod, clods, clay lumps, pockets of coarse sand, concrete slurry, concrete layers or chunks, cement, plaster, building debris, and other extraneous materials harmful to plant growth.
 - 1. Planting Soil: Planting soil as specified in Section 329115 "Soil Preparation (Performance Specification)."
- B. Organic Mulch: Free from deleterious materials and suitable as a top dressing for trees and shrubs, consisting of one of the following:

1. Type: Shredded hardwood or wood and bark chip .
 2. Size Range: 3 inches maximum, 1/2 inch minimum .
 3. Color: Natural.
- C. Protection-Zone Fencing: Fencing fixed in position and meeting one of the following requirements:
1. Chain-Link Protection-Zone Fencing: Galvanized-steel fencing fabricated from minimum 2-inch opening, 0.148-inch- diameter wire chain-link fabric; with pipe posts, minimum 2-3/8-inch- OD line posts, and 2-7/8-inch- OD corner and pull posts ; with 1-5/8-inch- OD top rails and 0.177-inch- diameter bottom tension wire; with tie wires, hog ring ties, and other accessories for a complete fence system.
 - a. Height: 72 inches .
 2. Gates: Single- swing access gates matching material and appearance of fencing, to allow for maintenance activities within protection zones; leaf width 36 inches .
- D. Protection-Zone Signage: Shop-fabricated, rigid plastic or metal sheet with attachment holes prepunched and reinforced; legibly printed with nonfading lettering and as follows:
1. Size and Text: 18 inches by 18 inches .
 2. Lettering: 3-inch high minimum, black characters on red background.

PART 3 - EXECUTION

3.1 EXAMINATION

- A. Erosion and Sedimentation Control: Examine the site to verify that temporary erosion- and sedimentation-control measures are in place. Verify that flows of water redirected from construction areas or generated by construction activity do not enter or cross protection zones.
- B. Prepare written report, endorsed by arborist, listing conditions detrimental to tree and plant protection.

3.2 PREPARATION

- A. Locate and clearly identify trees, shrubs, and other vegetation to remain . Flag or Tie a 1-inch blue vinyl tape around each tree trunk at 54 inches above the ground.
- B. Protect tree root systems from damage caused by runoff or spillage of noxious materials while mixing, placing, or storing construction materials. Protect root systems from ponding, eroding, or excessive wetting caused by dewatering operations.
- C. Tree-Protection Zones: Mulch areas inside tree-protection zones and other areas indicated. Do not exceed indicated thickness of mulch.
 1. Apply 4-inch uniform thickness of organic mulch unless otherwise indicated. Do not place mulch within 6 inches of tree trunks.

3.3 PROTECTION ZONES

- A. Protection-Zone Fencing: Install protection-zone fencing along edges of protection zones before materials or equipment are brought on the site and construction operations begin in a manner that will prevent people from easily entering protected areas except by entrance gates. Construct fencing so as not to obstruct safe passage or visibility at vehicle intersections where fencing is located adjacent to pedestrian walkways or in close proximity to street intersections, drives, or other vehicular circulation.
 - 1. Chain-Link Fencing: Install to comply with ASTM F 567 and with manufacturer's written instructions.
 - 2. Posts: Set or drive posts into ground one-third the total height of the fence without concrete footings. Where a post is located on existing paving or concrete to remain, provide appropriate means of post support acceptable to Architect.
 - 3. Access Gates: Install where indicated ; adjust to operate smoothly, easily, and quietly; free of binding, warp, excessive deflection, distortion, nonalignment, misplacement, disruption, or malfunction throughout entire operational range. Confirm that latches and locks engage accurately and securely without forcing or binding.
- B. Protection-Zone Signage: Install protection-zone signage in visibly prominent locations in a manner approved by Architect. Install one sign spaced approximately every 20 feet on protection-zone fencing, but no fewer than four signs with each facing a different direction.
- C. Maintain protection zones free of weeds and trash.
- D. Maintain protection-zone fencing and signage in good condition as acceptable to Architect and remove when construction operations are complete and equipment has been removed from the site.
 - 1. Do not remove protection-zone fencing, even temporarily, to allow deliveries or equipment access through the protection zone.
 - 2. Temporary access is permitted subject to preapproval in writing by arborist if a root buffer effective against soil compaction is constructed as directed by arborist. Maintain root buffer so long as access is permitted.

3.4 EXCAVATION

- A. General: Excavate at edge of protection zones and for trenches indicated within protection zones according to requirements in Section 312000 "Earth Moving" unless otherwise indicated.
- B. Trenching within Protection Zones: Where utility trenches are required within protection zones, excavate under or around tree roots by hand or with pneumatic excavation device, or tunnel under the roots by drilling, auger boring, or pipe jacking. Do not cut main lateral tree roots or taproots; cut only smaller roots that interfere with installation of utilities. Cut roots as required for root pruning. If excavating by hand, use narrow-tine spading forks to comb soil and expose roots.
- C. Redirect roots in backfill areas where possible. If encountering large, main lateral roots, expose roots beyond excavation limits as required to bend and redirect them without breaking. If encountered immediately adjacent to location of new construction and redirection is not practical, cut roots approximately 3 inches back from new construction and as required for root pruning.

- D. Do not allow exposed roots to dry out before placing permanent backfill. Provide temporary earth cover or pack with peat moss and wrap with burlap. Water and maintain in a moist condition. Temporarily support and protect roots from damage until they are permanently relocated and covered with soil.

3.5 ROOT PRUNING

- A. Prune tree roots that are affected by temporary and permanent construction. Prune roots as follows:
 - 1. Cut roots manually by digging a trench and cutting exposed roots with sharp pruning instruments; do not break, tear, chop, or slant the cuts. Do not use a backhoe or other equipment that rips, tears, or pulls roots.
 - 2. Cut Ends: Do not paint cut root ends .
 - 3. Temporarily support and protect roots from damage until they are permanently redirected and covered with soil.
 - 4. Cover exposed roots with burlap and water regularly.
 - 5. Backfill as soon as possible according to requirements in Section 312000 "Earth Moving."
- B. Root Pruning at Edge of Protection Zone: Prune tree roots 6 inches inside of the protection zone by cleanly cutting all roots to the depth of the required excavation.
- C. Root Pruning within Protection Zone: Clear and excavate by hand or with air spade to the depth of the required excavation to minimize damage to tree root systems. If excavating by hand, use narrow-tine spading forks to comb soil to expose roots. Cleanly cut roots as close to excavation as possible.

3.6 CROWN PRUNING

- A. Prune branches that are affected by temporary and permanent construction. Prune branches as directed by arborist.
 - 1. Prune to remove only injured, broken, dying, or dead branches unless otherwise indicated. Do not prune for shape unless otherwise indicated.
 - 2. Do not remove or reduce living branches to compensate for root loss caused by damaging or cutting root system.
 - 3. Pruning Standards: Prune trees according to ANSI A300 (Part 1).
- B. Unless otherwise directed by arborist and acceptable to Architect, do not cut tree leaders.
- C. Cut branches with sharp pruning instruments; do not break or chop.
- D. Do not paint or apply sealants to wounds.
- E. Provide subsequent maintenance pruning during Contract period as recommended by arborist.
- F. Chip removed branches and stockpile in areas approved by Architect or dispose of off-site.

3.7 REGRADING

- A. Lowering Grade: Where new finish grade is indicated below existing grade around trees, slope grade beyond the protection zone. Maintain existing grades within the protection zone.
- B. Lowering Grade within Protection Zone: Where new finish grade is indicated below existing grade around trees, slope grade away from trees as recommended by arborist unless otherwise indicated.
 - 1. Root Pruning: Prune tree roots exposed by lowering the grade. Do not cut main lateral roots or taproots; cut only smaller roots. Cut roots as required for root pruning.
- C. Raising Grade: Where new finish grade is indicated above existing grade around trees, slope grade beyond the protection zone. Maintain existing grades within the protection zone.
- D. Minor Fill within Protection Zone: Where existing grade is 3 inches or less below elevation of finish grade, fill with backfill soil. Place backfill soil in a single uncompacted layer and hand grade to required finish elevations.

3.8 FIELD QUALITY CONTROL

- A. Inspections: Engage a qualified arborist to direct plant-protection measures in the vicinity of trees, shrubs, and other vegetation indicated to remain and to prepare inspection reports.

3.9 REPAIR AND REPLACEMENT

- A. General: Repair or replace trees, shrubs, and other vegetation indicated to remain or to be relocated that are damaged by construction operations, in a manner approved by Architect.
 - 1. Submit details of proposed pruning and repairs.
 - 2. Perform repairs of damaged trunks, branches, and roots within 24 hours according to arborist's written instructions.
 - 3. Replace trees and other plants that cannot be repaired and restored to full-growth status, as determined by Architect.
- B. Trees: Remove and replace trees indicated to remain that are more than 25 percent dead or in an unhealthy condition before the end of the corrections period or are damaged during construction operations that Architect determines are incapable of restoring to normal growth pattern.
 - 1. Small Trees: Provide new trees of same size and species as those being replaced for each tree that measures 4 inches or smaller in caliper size.
 - 2. Large Trees: Provide two new tree(s) of 3 inch caliper size for each tree being replaced that measures more than 6 inches in caliper size.
 - a. Species: As selected by Architect .
 - 3. Plant and maintain new trees as specified in Section 329300 "Plants."
- C. Excess Mulch: Rake mulched area within protection zones, being careful not to injure roots. Rake to loosen and remove mulch that exceeds a 4-inch uniform thickness to remain.

- D. Soil Aeration: Where directed by Architect, aerate surface soil compacted during construction. Aerate 10 feet beyond drip line and no closer than 36 inches to tree trunk. Drill 2-inch- diameter holes a minimum of 12 inches deep at 24 inches o.c. Backfill holes with an equal mix of augured soil and sand.

3.10 DISPOSAL OF SURPLUS AND WASTE MATERIALS

- A. Disposal: Remove excess excavated material, displaced trees, trash, and debris and legally dispose of them off Owner's property.

END OF SECTION 015639

SECTION 021000 - GENERAL DEMOLITION

PART 1 - GENERAL

1.1 RELATED DOCUMENTS

- A. Drawings, conditions of the Contract (including General, Supplementary, and Special Conditions), Division 01 Specification Sections and all other Contract Documents apply to work of this Section.

1.2 SUMMARY

A. Section Includes

1. The Contractor shall furnish all tools, equipment, materials, and supplies and shall perform all labor as required for the demolition, salvage, relocation, and removal of electrical and mechanical equipment, structures, bulkhead and facilities as indicated on the Contract Drawings and as specified herein.
2. The Work of this Section shall include, but shall not be limited to, the following items:
 - a. Demolition of asphalt pavement, concrete, and other features as required to install new pavements, utilities, equipment and other structures (such as the Steel Sheet Pile bulkhead).
 - b. Demolition, salvage, relocation, and removal of existing facilities, equipment, structures, pads and utilities as indicated on the Contract Drawings.
 - c. Abandonment of existing structures and facilities as specified on the Contract Drawings.
 - d. All items shown or specified to be demolished on Contract Documents.

B. Related Requirements

1. The following is a list of Specifications which may be related to this Section:
 - a. Section 312000 - Earth Moving
 - b. Section 311000 - Site Clearing

1.3 DEMOLITION COORDINATION

- A. The Contractor shall carefully coordinate the extent of demolition in areas where existing utilities are to be reconnected to new facilities and where existing facilities are to remain operational.
- B. While work is being performed, the Contractor shall provide adequate access to all operating equipment for routine operation and maintenance. The Contractor shall erect and maintain fences, warning signs, barricades, and other devices as required for the protection of the Contractor's employees, Battery Park City Authority's personnel and the general public. The Contractor shall remove all such protection when the work is completed or as directed by the Engineer.
- C. The Contractor shall coordinate all demolition and construction work with the Engineer.

1.4 SUBMITTALS

- A. Submittals for items specified herein shall be submitted by the Contractor and shall be in accordance with the Contract Documents.
 - 1. A copy of this specification section, with any addendum updates included, and all referenced and applicable sections, with any addendum updates included, shall be submitted with each paragraph check-marked to indicate specification compliance or marked to indicate requested deviations from specification requirements. Check marks (✓) shall denote full compliance with a paragraph as a whole. If deviations from the specifications are indicated, and therefore requested by the Contractor, each deviation shall be underlined and denoted by a number in the margin to the right of the identified paragraph. The remaining portions of the paragraph not underlined will signify compliance on the part of the Contractor with the specifications. The submittal shall be accompanied by a detailed, written justification for each deviation. Failure to include a copy of the marked-up specification sections, along with justification(s) for any requested deviations to the specification requirements, with the submittal shall be sufficient cause for rejection of the entire submittal with no further consideration.
- B. Submittals shall be provided to confirm that materials to be used comply with information specified herein.
- C. Demolition and equipment removal procedures shall be submitted to the Engineer for review and approval at least fourteen (14) calendar days prior to beginning work. The procedures shall provide for safe conduct of the Work, careful removal and disposition of materials and equipment, protection of facilities property which are to remain undisturbed, coordination with existing facilities to remain in service, and timely disconnection of utility services. The procedures shall include a detailed description of the methods and equipment to be used for each operation, and the sequence of operation.
- D. Deactivating Existing Facilities. The Contractor shall advise the Engineer in writing not less than fourteen (14) calendar days in advance of the time of any necessary deactivation of existing facilities or equipment which are to be removed, abandoned, modified, or connected to the new work.

1.5 REPAIR OF DAMAGE

- A. Any damage to remaining equipment, structures to remain, and other existing facilities to remain, as caused by the Contractor's operations shall be repaired at the Contractor's expense.
- B. Damaged items shall be repaired or replaced with new materials as required to re-store damaged items or surfaces to a condition equal to and matching that existing prior to damage or start of work of this Contract.

1.6 PROTECTION OF EXISTING UTILITIES AND WORK

- A. Before beginning any cutting, excavation/trenching or demolition work, the Contractor shall carefully survey the existing work and examine the Contract Drawings and Specifications to determine the extent of the Work. The Contractor shall take all necessary precautions to prevent damage to existing facilities which are to remain in place and in operation.

- B. The Contractor shall be responsible for any damages to existing facilities, which are caused by the operations of the Contractor. Damages to such work shall be re-paired or replaced to its existing condition at no additional cost to the Battery Park City Authority.
- C. The Contractor shall carefully coordinate the Work of this Section with all other work and construction and shall provide shoring, bracing, and supports, as required.
- D. The Contractor shall protect all aboveground and subsurface utilities within the limits of the demolition; in particular, removal of subsurface soils and dewatering may affect the bearing soils of nearby utility structures – these work will be coordinated with the Engineer to assess and provide input on the effect of the excavation of soils or dewatering (where warranted) and measures to protect these structures, at no additional expense to Battery Park City Authority and the Client.
- E. The Contractor shall ensure that structural elements are not overloaded and shall be responsible for increasing structural supports or adding new supports as may be required as a result of any cutting, removal, or demolition work performed under any part of this Contract.
- F. The Contractor shall remove all temporary protection when the Work is complete or when so authorized by the Engineer.
- G. The Contractor shall carefully consider all bearing loads and capacities for place-ment of equipment and material on site. In the event of any questions as to whether an area to be loaded has adequate bearing capacity, the Contractor shall consult with the Engineer prior to the placement of such equipment or material.

1.7 BURNING

- A. The use of burning at the project site for the disposal of refuse, debris, and waste materials resulting from demolition and site clearing operations will not be permit-ted.

1.8 ELECTRICAL DEMOLITION

- A. All electrical demolition work shall at all times be conducted by the Contractor in a safe and proper manner to avoid injury from electrical shock to the Battery Park City Authority's personnel and Contractor's personnel.
- B. Intermediate and final electrical systems shall meet the requirements of the New York City Electrical Code. Electrical equipment to be shut off for a period of time shall be tagged and locked-out. At no time shall live electrical wiring or connec-tions or those which can become energized be accessible to Contractor, Battery Park City Authority, or other personnel without suitable protection and warning signs.

PART 2 - EXECUTION

2.1 DEMOLITION

- A. The Contractor shall remove the existing bulkhead after installation of the new steel sheet pile bulkhead.

- B. Disposal of all materials shall be performed in compliance with all applicable local, State, and Federal codes and requirements. No trace of these structures shall remain prior to placing of backfill in the areas from which structures were removed.
- C. The Contractor shall note that the Contract Drawings used in this Contract to indicate demolition are based on Contract Drawings of the existing facilities. The Contract Drawings have been included to clarify the scope of work, although the Contractor must rely on his/her own inspection to determine the true arrangement and location of items.
- D. Contract Drawings identify the major equipment, utilities and structures and facilities to be demolished. Auxiliary systems such as water, auxiliary equipment, drainage, electrical wiring, controls, and instrumentation are not necessarily shown. In association with the major electrical equipment demolition, the following work shall also be performed at no additional cost to the Battery Park City Authority.
 - 1. All exposed electrical conduits, raceways, and conductors associated with demolished or relocated equipment, devices, and instruments shall ultimately be removed. Reuse of existing exposed conduits is not acceptable except where explicitly shown on the Contract Drawings. All resulting holes in structures from any demolition activity shall be repaired.
 - 2. Connection to existing underground conduits, demolition, and repair of surfaces shall meet all of the applicable requirements of Division 16 - Electrical.
 - 3. All electrical supports for demolished equipment including concrete pads, baseplates, mounting bolts, instrumentation supports and brackets, and support hangers shall be removed. Any damage to the existing structure shall be repaired as specified herein.
 - 4. The area and equipment shall be thoroughly cleaned, repaired, and touched up such that little or no evidence of the previous equipment installation remains.
- E. Wiring demolition shall be performed by licensed Electricians. Before removing or cutting wiring, check to be sure that it is wiring intended to be cut or removed, and label wiring which is to remain. Labels shall be fully documented on wiring diagrams, interconnection diagrams, elementary diagrams, and conduit and wire schedules. Wire bundles shall be rolled up and placed "out of the way" to the extent practicable.
- F. Where existing materials and equipment are removed or relocated, remove all materials no longer used such as studs, straps, conduits, and wires. Remove or cut off concealed or embedded conduit, boxes, or other materials and equipment to a point at least 3/4 inch below the final finished surface.
- G. Asphalt and/or concrete pavement shall be removed as necessary to perform the specified work. The limits of removal shall be neatly sawcut and dust mitigation shall be performed by the Contractor.
- H. When the required improvements have been constructed, new concrete and/or asphalt pavement shall be constructed as specified.
- I. Where cobblestones and/or decorative pavers are present within the limits of the excavation, these items shall be removed carefully and stored at the appropriate facility where it is not degraded or compromised. These items shall be installed similar to their original condition, style and orientation.

- J. Where existing pipes and electrical conduits, supports, or hangers are removed from existing structures, the Contractor shall fill all resulting holes in the structures and repair any resulting damage such that the finished rehabilitated structure shall appear as a new homogeneous unit with little or no indication of where the new and old materials join.
- K. The holes, gaps and or open joints in utility vaults or structures shall be sealed or filled with non-shrink grout to be watertight and reinforced as required, or as shown on the Contract Drawings.
- L. At all locations where the surface of the seal or grout will be exposed to view, the seal or non-shrink grout shall be recessed to approximately 1/2-inch back of the exposed surface and the recessed area filled with cement mortar grout.
- M. Perimeter work fence and gates shall be maintained at all times to ensure security.

2.2 SALVAGED MATERIA

- A. Existing materials and equipment to be salvaged shall remain the property of the Battery Park City Authority. Salvage to be reinstalled in the Work shall be refurbished as shown or specified before reinstallation.
- B. Salvaged material shall be carefully removed and handled in such a manner as to avoid damage and shall be cleaned prior to their delivery.

2.3 DISPOSAL

- A. The Contractor shall be responsible for the removal from the job site and disposal of all demolition refuse and debris not specifically identified for salvage by the Battery Park City Authority. In addition, the Contractor shall be responsible for disposal of all items associated with equipment to be demolished such as fuel, antifreeze, oil etc. The Contractor shall in doing so comply with all applicable laws, codes, ordinances and regulations, and shall obtain and pay for all necessary permits. Demolition materials removed from the site for legal disposal and not specifically identified for salvage by the Battery Park City Authority shall be the property of the Contractor.

END OF SECTION 021000

THIS PAGE INTENTIONALLY LEFT BLANK

SECTION 031000 - CONCRETE FORMWORK

PART 1 - GENERAL

1.1 DESCRIPTION OF WORK

- A. Provide design, supply, installation and removal of forms wherever necessary to confine concrete and shape it to required dimensions. Provide special formwork or form liners for concrete with smooth or special finishes. Provide all required bracing, shoring and reshoring.

1.2 RELATED SECTIONS

- A. Concrete Reinforcement.....Section 03200
- B. Cast-in-Place Concrete.....Section 03300

1.3 REFERENCES

- A. References and industry standards listed in this Section are applicable to the Work. Unless more stringent criteria or differing requirements are explicitly stated in the Specifications, or mandated by governing codes or regulations, the recommendations, suggestions, and requirements described in the referenced standards shall be deemed mandatory and applicable to the Work.

American Concrete Institute (ACI) standards, latest editions.

- 1. ACI 301 Specifications for Structural Concrete for Buildings.
- 2. ACI 347 Guide to Formwork for Concrete.

1.4 DESIGN REQUIREMENTS

- A. The design and engineering of the formwork, as well as its construction, is the responsibility of the Contractor.
- B. Design formwork in accordance with ACI 347 and Section BC 1906 of the 2014 NYC Building Code.

1.5 SUBMITTALS

- A. Product Data - Submit manufacturers' information for the following:
 - 1. Overlaid plyform formwork or form liners
 - 2. Ties, each type and where to be used
 - 3. Form-release agent. Form-release agent to be submitted for review only.

- B. Samples

Submit 12" x 12" samples of the following items:

1. Overlaid plyform formwork or form liners
- C. Shop Drawings
1. Prepare and submit formwork shop drawings and calculations prepared and sealed by a Professional Engineer licensed in the State of New York for review when required by Section BC 1906.3 of the 2014 NYC Building Code.
- D. Quality Control Submittals
1. Contractor Qualifications: Provide proof of Formwork Installer qualifications specified under "Quality Assurance".
- 1.6 QUALITY ASSURANCE
- A. Qualifications
1. Company specializing in performing the Work of this Section shall have three years minimum experience.
 2. Person responsible for inspection of formwork shall be a qualified person as defined in Section BC 3302.1 of the 2014 NYC Building Code.
- B. Regulatory Requirements
1. Building Code: Work of this Section shall conform to all requirements of the NYC Building Code. Where more stringent requirements than those contained in the Building Code are given in this Section and ACI 347, the requirements of this Section and ACI 347 shall govern.
 2. Industrial Code Rule #23 of the Department of Labor, paragraphs 23.10.1 to 23-10.5 inclusive.
 3. ACI 347.
- 1.7 DELIVERY, STORAGE, AND HANDLING
- A. Protection
1. Protect formwork materials before, during and after installation.
 2. Protect installed work and materials of other trades.
- B. Replacement
1. Repair or replace damaged formwork as approved by the Owner/Developer.
 2. Repair overlaid plyform formwork as per manufacturer's instructions. Replace pieces when number of manufacturer recommended reuses is up or when finish deteriorates.

PART 2 - PRODUCTS

2.1 MATERIALS

- A. Rough Formwork Shall be Commercial Douglas Fir, DFPA: 5/8" thick minimum or modular metal units.
- B. Overlaid Plyform Formwork
 - 1. Plywood with thermosetting phenolic resin or urethane coating bonded to it to provide a flat matte finish. Shall be equal to B-Matte Formguard by Simpson Timber Company.
- C. Smooth Form Finish Form liner
 - 1. Shall be equal to #340 Smooth Face by Greenstreak.
 - 2. Nails and staples used to attach form liner to formwork are to be Type 304 stainless steel.
- D. Left-in-Place Forms: Galvanized per ASTM A653, coating designation G90, and not less than 20 gage.
- E. Release Agent
 - 1. VOC compliant material such as those of the Cresset Chemical Company for coating forms. Shall be compatible with material or finish to be subsequently applied and free of deleterious effects on final surfaces. Form oils shall not contain castor oil. Release agents shall not discolor concrete where concrete is to be exposed to view.
- F. Form Sealers: Shall be guaranteed by manufacturer to be non-staining and to not impair the bond of paint, waterproofing or other required surface coatings.
 - 1. Sealer for lumber surfaces and plywood edges shall be clear polyurethane.
 - 2. Sealer for board forms shall be penetrating, non-staining and not leave a surface coating.
- G. Form Ties
 - 1. Form ties for exposed concrete shall be adjustable.
 - 2. Form ties for exposed concrete and concrete to receive membranes shall be a break-off type and leave no metal closer than 1¹/₂-inch to the surface.
 - 3. Form ties for concrete stated in 2 above shall be free of devices which leave holes or depressions larger than 7/8"-inch back of exposed surface.
 - 4. Wire ties not permitted.
 - 5. Ties shall have a minimum capacity of 3000 pounds.

PART 3 - EXECUTION

3.1 PREPARATION OF FORMWORK SURFACES

- A. Clean all surfaces of forms and embedded items of any accumulated mortar or grout from previous concreting and other foreign material before concrete is placed in them. Clean, repair and patch reused forms as required to return them to acceptable condition. Repair or replace any formwork as required.
- B. Before placing either reinforcing steel or concrete, cover the surfaces of the rough or overlaid plyform formwork (when used) with an approved form release agent that will effectively prevent absorption of moisture, prevent bond with the concrete, and which will not stain the concrete surfaces. Coat steel forms with a non-staining, rust-preventative releasing agent. Material shall be carefully applied at the amount recommended by the release agent manufacturer to obtain the desired finish. Do not apply oil or release agents on formwork for concrete to receive coatings such as membrane waterproofing, plaster, or additional concrete (such as at construction joints). Follow manufacturer's recommendations for alternatives. For the overlaid plyform formwork, release agent should be a chemically reactive agent compatible with the factory treatment. Do not allow excess form coating material to stand in puddles in the forms nor allow coating to come in contact with hardened concrete against which fresh concrete is to be placed.

3.2 CONSTRUCTION AND DETAILS

- A. Contractor shall be solely responsible for the design, construction, erection, removal, safety and adequacy of all concrete formwork, falsework, shoring, reshoring and the like. Design, erect, support, brace, and maintain formwork to support vertical and lateral, static and dynamic loads that might be applied, until such loads can be supported by the concrete structure. Design formwork to be readily removable without impact, shock, or damage to cast in place concrete surfaces and adjacent materials.
- B. Adequately support and substantially brace formwork to hold lines, shape, alignment, plumbness and position.
- C. Formwork shall be tight jointed to prevent leakage of mortar from the concrete.
- D. Place chamfer strips in the corners of forms to produce beveled edges (chamfers) on permanently exposed surfaces (such as exposed columns). Do not provide beveled edge for interior corners of such surfaces and where members are flush with partitions or walls, unless required by Drawings or specified elsewhere.
- E. Set slab-forms with camber of 1/4-inch per 10 feet of span to maintain tolerances. For two way slabs the lesser span dimension shall govern.
- F. Provide positive means of adjustment (wedges or jacks) for shores and struts to take up all settlement during concrete placing operations. Fasten wedges used for final adjustment of forms prior to concrete placement in position after final check. Securely brace forms against lateral deflection.
- G. Provide mud sills where shores rest on compressible materials.

- H. Provide temporary openings to permit cleaning and inspection. Provide ample time for proper inspection before placement of concrete.
- I. Provide "Rough Form Finish" for surfaces not exposed to view. Use plywood or metal forms coated with a release agent.
- J. Provide "Smooth Form Finish" for surfaces exposed to view. Use dress, square-edged lumber with form liner or overlaid plyform forms with applicable release agent. Do not exceed manufacture's recommendations for number of re-uses for the form liner or overlaid plyform. Arrange the forms or form liner in an orderly and symmetrical fashion, keeping the number of seams to a practical minimum. Items indicated as "Architectural Concrete" or Architectural Finish" shall use specially designed formwork to attain the desired finish and shall have a CS 1 surface finish as developed by the Cresset Chemical Company, or other special finish specified. Other exposed concrete shall have CS3 or better surface finish.
- K. Provide openings in formwork to accommodate work of other trades. Form holes for pipes, pipe sleeves, electric outlets, electric conduits, etc. as required. Construct wood forms for wall forms to facilitate loosening, if necessary, to counteract swelling of forms.
- L. Provide runways for moving equipment with struts or legs, which shall be supported directly on the formwork or structural member without resting on the reinforcing steel.
- M. Provide for rebates, offsets, sinkages, keyways, moldings, blocking, bulkheads, anchorages, embeds, reglets, grooves keys, pockets, ground nailers, projections and other built-in work prior to placement of concrete. Install reglets as per manufacturer's instructions.
- N. Install dovetail slots, concrete inserts, and other metal fabrications. Secure to inside forms and space as shown on Drawings.
- O. At construction joints, contact surface of the form sheathing for flush surfaces exposed to view shall overlap the hardened concrete in the previous placement by not more than 1". The forms shall be held against the hardened concrete to prevent offsets or loss of mortar at the construction joint and to maintain a true surface.
- P. Form accessories to be partially or wholly embedded in the concrete, such as ties and hangers, shall be of a commercially manufactured type. Use of non-fabricated wire is not permitted. Construct form ties so that the ends or end fasteners can be removed without causing appreciable spalling at the faces of the concrete. After the ends or end fasteners of the form ties have been removed, terminate the embedded portion of the ties not less than 2 diameters or twice the minimum dimension of the tie from the formed faces of concrete to be permanently exposed to view, except that in no case shall this distance be less than 3/4".
When the formed face of the concrete is not to be permanently exposed to view, form ties may be cut off flush with the formed surfaces.
- Q. Carefully check all forms before placement of concrete.
- R. Notify the Engineer of Record if openings are required but not shown on the Drawings, who will issue instructions accordingly.

- S. Provide top forms for inclined surfaces where slope is too steep to place concrete with bottom forms only.
- T. Provide form ties at spacing as required to hold formwork readily and eliminate visible deflection and building of formwork surfaces as well as safely resist all applied loads. Ties shall be coated with an approved bond breaker.
- U. Fabricate forms for easy removal without hammering or prying against concrete surfaces. Provide crush plates or wrecking plates where stripping may damage cast concrete surfaces. Kerf wood inserts for forming keyways, reglets, recesses, and the like, to prevent swelling and for easy removal.
- V. For concrete exposed to view locate ties in level and plumb lines in an arrangement acceptable to the architect.
- W. Provide square exposed corners and edges as indicated on architectural drawings, using wood, metal, or PVC strips fabricated to produce uniform smooth lines and tight edge joints.

3.3 REMOVAL OF FORMS AND SHORING

- A. Remove forms in such a manner as to assure the complete safety of the structure as required by Section BC 1906.2 of the 2014 NYC Building Code. In no case remove forms or shoring supporting the weight of concrete in beams, slabs or structural members until the members have reached the minimum compressive strength specified on the Drawings or as permitted by the Engineer of Record.
- B. Contractor shall be solely responsible for proper and safe removal of forms, shoring, and removal of reshoring. Contractor shall do cost of tests and/or calculations needed to determine such techniques, timing and sequences without expense to Owner, Architect or Engineer.
- C. Formwork for columns, walls, sides of beams, and other parts not supporting the weight of the concrete may be removed as soon as the concrete has hardened sufficiently to resist damage from removal operations and as required by D below. For temperatures not less than 50 deg F this shall be a minimum of 36 hours after placement. Provide effective curing and protection.
- D. Unless reshoring is used, formwork supporting weight of concrete, such as beam soffits, joists, slabs, and other structural elements, may not be removed in less than the time period specified in ACI 347, paragraph 3.7.2.3 unless concrete has attained 75 percent of specified compressive strength at an earlier time. Determine compressive strength of in place concrete by testing field cured cylinders representative of concrete location or members. The Contractor shall pay the cost of such testing.
- E. When repair of surface defects or finishing is required at an early age, remove forms as soon as the concrete has hardened sufficiently to resist damage from removal operations.

- F. Remove top forms on sloping surfaces of concrete as soon as the concrete has attained sufficient stiffness to prevent sagging. Perform any needed repairs or treatment required on such sloping surfaces at once and follow it with the specified curing.
- G. Loosen wood forms for wall openings as soon as this can be accomplished without damage
- H. Contractor shall replace or repair, at Engineer's direction, any and all work damaged by improper removal or reshoring operations.

3.4 TOLERANCES

- A. Construct formwork so that concrete surfaces will conform to the tolerance limits listed in ACI 117.
- B. Establish and maintain in an undisturbed condition and until final completion and acceptance of the project sufficient control points and bench marks to be used for reference purposes to check tolerances.
- C. Regardless of the tolerances listed, do not extend any portion of the concrete work beyond the lot or street line.

3.5 INSPECTION

- A. Under the requirements of Section BC 1906 of the 2014 NYC Building Code, formwork, including shores, braces, and other supports shall be inspected by a qualified person engaged by the Contractor. The qualified person shall make inspections prior to placement of steel to verify correct sizes of members formed and subsequently periodically after placement and during placement of concrete to detect incipient problems. Maintain a record of all inspections.
- B. Under the requirements of Section 1704.4 of the Building Code, the Owner/Developer will assign a Special Inspector to inspect formwork for size of members and to verify in-situ concrete strengths prior to removal of formwork and shores from beams and slabs.
- C. During and after concrete placement, check elevations, camber, and vertical alignment of formwork systems using tell-tale devices.
- D. Keep a record of all inspections, the name of the persons making them, and the name of the foreman in charge of formwork at the site. Submit to the Owner/Developer's representative on the site a copy of the inspection records prior to each concrete placement.

END OF SECTION -031000

SECTION 032000 - CONCRETE REINFORCEMENT

PART 1 - GENERAL

1.1 DESCRIPTION OF WORK

- A. Provide and install all reinforcement, stud rails, reinforcing supports and associated items required for cast-in-place.

1.2 RELATED SECTIONS

- A. Concrete Formwork.....Section 03100
- B. Cast-in-Place Concrete.....Section 03300

1.3 REFERENCES

References and industry standards listed in this Section are applicable to the Work. Unless more restrictive criteria or differing requirements are explicitly stated in the Specifications, or mandated by governing codes or regulations, the recommendations, suggestions, and requirements described in the referenced standards shall be deemed mandatory and applicable to the Work.

- A. American Society of Testing and Materials (ASTM) standards, latest editions.
 - A82 Standard Specification for Steel Wire, Plain, for Concrete Reinforcement.
 - A185 Standard Specification for Steel Welded Wire Reinforcement, Plain, for Concrete Reinforcement.
 - A1064 Standard Specification for Steel Wire, Deformed, for Concrete Reinforcement.
 - A615 Standard Specifications for Deformed and Plain Billet-Steel Bars for Concrete Reinforcement.
 - A706 Standard Specifications for Low-Alloy Steel Deformed and Plain Bars for Concrete reinforcement
 - A767 Standard Specifications for Zinc-Coated (Galvanized) Steel Bars for Concrete Reinforcement
 - A775 Standard Specifications for Epoxy-Coated Reinforcing Steel Bars
 - A780 Standard Specifications for Repair of Damaged and Uncoated Areas of Hot-Dip Galvanized Coatings
- B. American Concrete Institute (ACI) standards, latest editions.
 - ACI 301 "Specification for Structural Concrete for Buildings."
 - ACI Detailing Manual SP66 (Includes ACI 315 & 315R)

ACI 318-11 "Building Code Requirements for Reinforced Concrete".

- C. "Placing Reinforcing Bars - CRSI-WCRSI Recommended Practices", latest edition. Concrete Reinforcing Steel Institute.
- D. "Structural Welding Code - Reinforcing Steel" D1.4 - American Welding Society (AWS).

1.4 DESIGN REQUIREMENTS

- A. Detailing requirements for reinforced concrete structures shall meet the structural integrity requirements as set in Section BC 1916 of the 2014 NYC Building Code.

1.5 SUBMITTALS

A. Product Data

Submit manufacturers' information for the following:

1. Steel welded wire fabric
2. Steel welded wire reinforcement.
3. Supports
4. Mechanical connectors

B. Shop Drawings

1. Submit shop drawings to the Engineer for acceptance in accordance with the requirements of the Contract Documents. Engineer shall have ten business days to review submittal packages from day after submittal arrives in Engineer's office until day that submittal is sent returned by Engineer. Submit drawings gradually and not all at the same time so that sufficient time is allowed for checking and approval.
2. At least two weeks prior to the first shop drawing submittal Contractor shall provide Engineer with a comprehensive list of all shop drawing submittals, and a schedule indicating when all submittals are to be sent to Engineer. If Contractor deviates from this schedule, Engineer shall be allowed additional time to review shop drawings
3. Shop drawings shall conform to the highest standards of the construction industry. Include enough plans, elevations, sections and details at adequate scale to completely describe all work to be provided. All detailing work shall be in accordance with ACI 315 and shall be not less complete than examples given in ACI SP 04. Improperly prepared and incomplete shop drawings will be disapproved without review.
4. Submit shop drawings to Engineer in coordinated packages so that all required information is in hand at time of review. Prior to resubmission of shop drawings, all changes from prior issue shall be clearly circled and identified. Do not fabricate before shop drawings have been reviewed and returned to Contractor marked "No Exceptions Taken" or "Make Corrections Noted" only.
5. Contractor shall coordinate and cross check for accuracy, completeness and correct relationship to the work of other sections, each shop drawing prepared for the work of this Section, including each shop drawing prepared by accepted subcontractors. Show and dimension holes required for passage of work of other sections through

- cast in place concrete. Engineer's review of shop drawings does not relieve Contractor from these responsibilities.
6. Prior to sending submittals to Engineer, Contractor and Construction Manager (if applicable) shall coordinate and cross-check for accuracy and completeness each shop drawing prepared for work of this Section with the approved Construction Documents and Specifications. Shop drawings shall bear the stamp of Contractor and Construction Manager indicating that this review has been performed. Engineer will not review submittals for which Contractor and Construction Manager have not performed this review.
 7. Reinforcing detail drawings shall include, but not be limited to the following:
 - a. Setting plans, wall elevations, detailed bending diagrams, cutting lists and other information so as to completely demonstrate the location, spacing, size, length, bending, shape of all reinforcing steel, and position and length of all splices.
 - b. The yield strength and ASTM designation of all reinforcing.
 - c. All control, expansion and construction joints including keys and waterstops.
 - d. Cover for reinforcing, indicated and shown on every shop drawing.
 - e. Wall reinforcing detailed on wall elevations, not on plans.
 - f. All openings, depressions, trenches, sleeves, embedded inserts and any other project requirements affecting reinforcing details and placing.
 - g. Type, size and location of all metal and plastic accessories required for the proper assembling, placing and support of the reinforcement.
 8. Reinforcing steel shop drawings must provide all information, sections, details and marks so that reinforcing steel can be easily placed without the use of any other drawings or information. Reproduction of Structural Drawings, in entirety or part, for use as shop drawing is not permitted.
 9. Detail reinforcing steel for curbs, pads, trenches, openings and the like from information given in Landscape Architectural, Civil, and other Contract Documents.
 10. Provide all reinforcement shown or scheduled in the Drawings, including that required by typical details and general notes, but not less than required by ACI Code minimums.
 11. Detailing of reinforcement shall consider the arrangement, shape and size of individual bars, including hooks and lap splices, so as to preclude interference between bars, and embedded items and to provide clear spacing and concrete cover as required by ACI 318. Provide placing sequence information when required to properly install reinforcement in the field. Provide enough sections and enlarged details, whether they are given on Structural Drawings or not, to fully illustrate placement locations.
 12. Fieldwork drawings shall be submitted for review of and acceptance for all work required to accommodate field conditions.
 13. Shop drawings will be checked for size of material and spacing by the Engineer of Record, which shall not render the Engineer responsible for any errors in construction dimensions, quantities, bends, etc. that have been made in preparation of the shop drawings. The Contractor shall assume full responsibility for the correctness of quantities, dimensions and fit.

C. Quality Control Submittals

1. Certificates

a. Submit to Testing Agency and Engineer certified copies of mill test reports for all steel reinforcement, including bars, welded wire fabric, stud rails, prestressing bars and strands.

2. Contractor Qualifications: Provide proof of Installer and Detailer qualifications specified under "Quality Assurance".

1.6 QUALITY ASSURANCE

A. Qualifications

1. Rebar Installer: Company specializing in performing the Work of this Section shall have three years minimum experience on successful projects of similar size and type.

2. Rebar Detailer: Company shall be specialized in the detailing of reinforcing bar shop drawings with a minimum of three years of experience on successful projects of similar size and type.

B. Regulatory Requirements

1. Building Code

Work of this section shall conform to all requirements of the NYC Building Code. Deliveries will be rejected unless:

a. All reinforcing bars are identifiable as to point of origin, grade of steel, and size.

b. All bundles or rolls of cold drawn steel wire reinforcement are securely tagged to identify the manufacturer, the grade of steel, and the size.

Where more severe requirements than those contained in the Building Code are given in this Section and ACI 318, the requirements of this Section and ACI 318 shall govern.

2. Industry Standards

Details of Concrete reinforcement not covered herein shall be in accordance with "Building Code Requirements for Reinforced Concrete" (ACI 318) and "Details and Detailing of Concrete Reinforcement" (ACI 315), latest editions and the Concrete Reinforcing Steel Institute Manual on "Placing Reinforcing Bars" (CRSI).

1.7 DELIVERY, STORAGE, AND HANDLING

A. Store in location to prevent rusting, etc.

B. Protect reinforcement before, during, and after installation.

- C. Insure proper identification after bundles are broken.

PART 2 - PRODUCTS

2.1 MATERIALS

A. Reinforcing Bars

1. All reinforcing bars, except those to be welded, shall be of deformed type of new billet steel conforming to current requirements of ASTM A615, and where not noted shall be Grade 60. No rail or re-rolled steel will be permitted. Reinforcement to be welded shall conform to the requirements of ASTM A706.
2. Grade or yield strength of reinforcing bars is indicated on Drawings.

B. Welded Steel Wire Fabric

1. Wire Fabric shall conform to the requirements of ASTM A185.
2. Required net area, placement details, and other requirements are indicated on Drawings.

C. Supports for Reinforcement

1. Supports for reinforcement supported by formwork or deck shall consist of metal bolsters and chairs of adequate strength, size, and number. Provide CRSI Class C supports (plastic tipped) for formed concrete surfaces and Class A (bright basic) for metal deck.
2. Support for reinforcement of footings/pile-caps shall consist of the above supports or precast concrete block, 4" square, having a compressive strength equal to that of the concrete being placed.

D. Mechanical Tension Splices for Reinforcing Bars: Cadweld Rebar Splices or Lenton Couplers by Erico Products, Inc., BarGrip by BarSplice Products Inc., or equivalent accepted by Engineer.

E. Mechanical Compression Splices for Reinforcing Bars: Speed-Sleeve Splices by Erico Products, Inc. or equivalent accepted by Engineer.

F. Shear Reinforcement: Studrails by Decon

G. Structural Macro Fibers: ASTM C 1116, minimum of 2 inches (50mm) length, aspect ratio of 50 to 90, minimum toughness rating of R10, 50 = 60 (approximate) according to ASTM C 1018. Manufacturer: The Euclid Chemical Company, "Tuf-Strand SF" or W.R. Grace "Strux 90.40".

2.2 FABRICATION

A. Fabricate reinforcing bars in accordance with fabricating allowances given in ACI 315 and accepted shop drawings.

1. Partially embedded reinforcement shall not be bent or re-bent without the express written acceptance of the engineer. Offset bars shall be bent before placing.

PART 3 - EXECUTION

3.1 PLACEMENT

A. General

1. Place reinforcement in accordance with CRSI "Placing Reinforcement Bars" and Section BC 1907.5 of the 2014 NYC Building Code.
2. Unless otherwise permitted, welding of crossing bars (tack welding) for assembly of reinforcement is prohibited.
3. Avoid cutting or puncturing vapor barrier during placement.
4. Clean reinforcement of loose rust and mill scale, earth, ice and other bond inhibiting materials.
5. Accurately position as shown on accepted shop drawings. Support and secure reinforcement against displacement by formwork, construction, or concrete placement operations. Locate and support reinforcing by metal chairs, runners, bolsters, spacers, and hangers, as required.

B. Supports

1. Support and fasten together all reinforcement to prevent displacement by construction loads or placing of concrete. Set wire ties so ends are directed into concrete, not toward exposed concrete surfaces. Tie wire ends shall not fall within required clear concrete cover.
2. Provide supports specified in Article 2.01.
3. Provide Continuous High Chair Upper (CHCU) or Continuous Support (CS) for welded wire fabric in the metal deck and place every four feet (4') parallel to the supporting beams.
4. Lifting of bars and welded wire fabric into position during placement of concrete is not permitted.
5. Where the concrete surface will be exposed to the weather in the finished structure, the portions of all accessories within 1/2" of the concrete surface shall be non-corrosive or protected against corrosion.
6. Neither top nor bottom bars shall be allowed to sag below tolerances specified herein.
7. For #8 bars and smaller, separate adjacent layers of parallel bars with short length of #8 bars, securely tied to the layers. For #9 bars and larger, separator bar shall be of the largest bar size separated.

C. Cover

1. Provide minimum protective cover given in Section 1907.7 of the 2014 NYC Building Code if not indicated on Drawings.
2. Place reinforcement to obtain at least minimum coverages for concrete protection as required.

D. Splices

1. All splices not shown on the Project Drawings shall be shown on the shop drawings and approved by the Engineer of Record.

2. Provide welded splices where indicated on Drawings. All welding shall conform to AWS D1.4. At these locations, only reinforcement conforming to ASTM A706 shall be used.
3. Provide mechanical connectors where indicated on Drawings. Install in accordance with splice device manufacturer's recommendations.
4. For welded wire reinforcing in slabs on ground lap adjoining pieces at least one full mesh plus two inches and lace splices with wire.

E. Embedment Lengths

All embedment lengths not shown on the Project Drawings shall be shown on the shop drawings and approved by the Engineer of Record.

3.2 TOLERANCES

A. Fabricate bars in accordance with the fabricating tolerances given in ACI 315. Place reinforcing bars in accordance with the tolerances given in Section 1907.5.2 of the 2014 NYC Building Code, ACI 318 Chapter 7, or provided herein, whichever is more stringent.

1. Bars shall be placed to the following tolerances:

- a. Clear distance to formed surfaces + ¼-inch
- b. Minimum spacing between bars + ¼-inch
- c. Top bars in slabs and beams:
 - 1) Members < 8" deep + ¼-inch
 - 2) 8" < Members < 24" deep + ½-inch
- d. Crosswise of members: spaced evenly within 2-inch
- e. Lengthwise of members: + 2-inch

B. Move bars as necessary to avoid interference with other reinforcement, conduits, or imbedded items. If bars are moved more than one bar diameter, or enough to exceed the above tolerances, the resulting arrangements are subject to approval by the Engineer of Record.

3.3 FIELD QUALITY CONTROL

A. Under the requirements of Section BC 1704.4 of the 2014 NYC Building Code, the Owner/Developer will assign a Special Inspector to inspect the size and placement of reinforcement. A record will be made of all inspection of reinforcement at the bending bench and in place.

B. Do not proceed with the completion of wall forms until all reinforcement has been approved and recorded by the Special Inspector.

C. Do not proceed with concreting until all reinforcing in place has been approved and recorded.

D. Promptly correct all reinforcement displaced during pouring of concrete.

- E. Protect reinforcing steel and mesh from scaling, oil, grease and distortion. Reinforcing steel and mesh that has rusted to the extent of scaling will be rejected and may be placed in the work only after proper cleaning and approval by the Testing Agency. Damaged reinforcement shall not be used.

3.4 CLEANING

- A. Steel reinforcement shall be free of all rust, scale, oil, paint, grease, loose mill scale, and all other foreign matter that will prevent bonding of concrete and steel just prior to pouring of concrete.

END OF SECTION 032000

LIST OF SUBMITTALS

SUBMITTAL	DATE SUBMITTED	DATE APPROVED
Product Data:		_____
1. Welded wire fabric		
2. Welded wire reinforcement		
3. Supports		
4. Mechanical connectors		
Shop Drawings:		_____
1. Reinforcement layout		
Certificates:		_____
1. Reinforcing bars		
2. Welded wire fabric		
3. Welded wire reinforcement		
Qualifications:		_____
1. Rebar Installer		
2. Rebar Detailer		
Sustainability:		_____
1. Contractor's Sustainable Materials Form (see Section S01352) with materials cost information.		

* * *

SECTION 033000 - CAST-IN-PLACE CONCRETE

PART 1 - GENERAL

1.1 DESCRIPTION OF WORK

- A. Drawings, conditions of the Contract (including General, Supplementary and Special Conditions), Division 1 Specification Sections and all other Contract Documents apply *to* work of this section.
- B. Extent of cast-in-place concrete is indicated on the Drawings, including layout and sizes of members, type and strength of concrete, reinforcing and accessories.
- C. Furnish material, equipment, labor, and services required to provide for cast-in-place concrete.
- D. Structural work includes but is not limited to footings, piers, pile caps, mats, pits, steel encasement, walls, beams, sleeves and openings, depressions and drops.
- E. Additional work includes but is not limited to contraction and control joints, keys, sitework, and installation of miscellaneous inserts, waterstops, vapor barriers, and other items listed herein. Also included is finishing of concrete exposed to view, designing and testing of concrete mixes, and submittals as listed in 1.08.
- F. All materials, equipment, labor and services required to complete the work. Allow ample time and facility for the Work of other Divisions to be installed.

1.2 PRODUCTS INSTALLED BUT NOT FURNISHED UNDER THIS SECTION

Products to be installed include, but are not limited to, the following:

- A. Anchor bolts and other anchors cast into concrete.....Section 05120

1.3 RELATED SECTIONS

- A. Sidewalk and Street Paving.....Section 02513
- B. Concrete Formwork.....Section 03100
- C. Concrete Reinforcement.....Section 03200

1.4 SUSTAINABILITY REQUIREMENTS

- A. The Contractor shall implement practices and procedures to meet the Project's sustainable requirements. The Contractor shall ensure that the requirements related to these goals, as defined in Specification Section S01352, Sustainability Requirements, and as specified in this Section, are implemented to the fullest extent. Substitutions or other changes to the work shall not be proposed by the Contractor or their sub-contractors if such changes compromise the stated Sustainable Design Performance Criteria.
- B. Sustainability requirements included in the Section are as follows:

1. Meet established minimum recycled content for concrete.
2. Documentation of Recycled materials.
3. Documentation of Regional materials.

1.5 REFERENCES

References and industry standards listed in this Section are applicable to the Work. Unless more restrictive criteria or differing requirements are explicitly stated in the Specifications, or mandated by governing codes or regulations, the recommendations, suggestions, and requirements described in the referenced standards shall be deemed mandatory and applicable to the Work.

- A. Conform to the requirements of the New York City Building Code.
- B. American Society of Testing and Materials (ASTM) standards, latest editions.
 - C31 Standard Practice for Making and Curing Concrete Test Specimens in the Field.
 - C33 Standard Specifications for Concrete Aggregates.
 - C39 Standard Test Method for Compressive Strength of Cylindrical Concrete Specimens.
 - C42 Standard Test Method for Obtaining and Testing Drilled Cores and Sawed Beams of Concrete.
 - C78 Standard Test Method for Flexural Strength of Concrete (Using Simple Beam with Three-point Loading)
 - C94 Standard Specification for Ready-Mixed Concrete.
 - C127 Standard Test Method for Density, Relative Density (Specific Gravity) and Absorption of Course Aggregate.
 - C131 Standard Test Method for Resistance to Degradation of Small-Size Coarse Aggregate by Abrasion and Impact in the Los Angeles Machine.
 - C138 Standard Test Method for Density (Unit Weight), Yield, and Air Content (Gravimetric) of Concrete.
 - C143 Standard Test Method for Slump of Hydraulic Cement Concrete.
 - C150 Standard Specification for Portland Cement.
 - C172 Standard Method of Sampling Freshly Mixed Concrete.
 - C173 Standard Test Method for Air Content of Freshly Mixed Concrete by the Volumetric Method.

- C192 Standard Practice for Making and Curing Concrete Test Specimens in the Laboratory.
- C231 Standard Test Method for Air Content of Freshly Mixed Concrete by the Pressure Method.
- C260 Standard Specifications for Air-Entraining Admixtures for Concrete.
- C309 Standard Specification for Liquid Membrane-Forming Compounds for Curing Concrete.
- C330 Standard Specification for Lightweight Aggregates for Structural Concrete.
- C387 Standard Specification for Packaged, Dry, Combined Materials for Mortar and Concrete.
- C494 Standard Specification for Chemical Admixture for Concrete.
- C496 Standard Test Method for Splitting Tensile Strength of Cylindrical Concrete Specimens.
- C567 Standard Test Method for Density of Structural Lightweight Concrete.
- C685 Standard Specification for Concrete Made by Volumetric Batching and Continuous Mixing.
- C882 Standard Test Method for Bond Strength of Epoxy-Resin Systems used with Concrete by Slant Shear
- C1315 Standard Specification for Liquid-Forming Compounds Having Special properties for Curing and Sealing Concrete
- E96 Standard Test Methods for Water Vapor Transmission of Materials
- E154 Standard Test Methods for Water Vapor Retarders Used in Contact with Earth Under Concrete Slabs
- E329 Standard Specification for Agencies Engaged in the Testing and/or Inspection of Materials used in Construction
- E1643 Standard Practicew for Installation of Water Vapor Retarders Used in Contact with Earth or Granular Fill Under Concrete Slabs
- E1745 Standard Specification for Plastic Water Vapor Retarders Used in Contact with Earth or Granular Fill Under Concrete Slabs

C. American Concrete Institute (ACI) standards.

- ACI 117 Standard Tolerances for Concrete Construction and Materials. Delete footnotes referring to buildings over 100ft., tolerances given shall apply over the full building height.

ACI 211.1	Standard Practice for Selecting Proportions for Normal, Heavyweight, and Mass Concrete.
ACI 211.2	Standard Practice for Selecting Proportions for Structural Lightweight Concrete.
ACI 212.3R	Chemical Admixtures for Concrete.
ACI 214R	Evaluation of Results of Tests Used to Determine the Strength of Concrete.
ACI 301	Specifications for Structural Concrete for Buildings.
ACI 302.1R	Guide for Concrete Floor and Slab Construction.
ACI 304R	Guide for Measuring, Mixing, Transporting and Placing Concrete.
ACI 304.2R	Placing Concrete by Pumping Methods
ACI 304.5R	Batching, Mixing and Job Control of Lightweight Concrete
ACI 305R	Hot Weather Concreting.
ACI 306R	Cold Weather Concreting.
ACI 308	Standard Practice for Curing Concrete.
ACI 309R	Guide for Consolidation of Concrete.
ACI 311.4R	Guide for Concrete Inspection.
ACI 318-11	Building Code Requirements for Reinforced Concrete (With modifications per Section BC 1908 of the 2014 NYC Building Code).
SP-66(04)	ACI Detailing Manual

D. American Association of State Highway and Transportation Officials

T318 Water Content of Freshly Mixed Concrete Using Microwave Oven Testing

1.6 DEFINITIONS

A. Exposed to view

Situated so that it can be seen from eye level from a public location. A public location is that which is accessible to persons not responsible for operation or maintenance of the building.

B. Normal weight concrete

Concrete for which density is not a controlling attribute, made with aggregates of the types covered by ASTM C33 and usually having unit weights in the range of 135 to 160 lb/ft³.

1.7 DESIGN REQUIREMENTS

A. Performance Characteristics:

1. All concrete shall adhere to the durability and minimum strength requirements set forth in Section BC 1904 of the Building Code.
2. Concrete strengths shall be as shown on the drawings and drawing notes.

1.8 SUBMITTALS

A. Product Data

Submit manufacturers' information for the following:

1. Admixtures
2. Curing compounds
3. Hardener
4. Bonding & Repair Agents
5. Beam clips
6. Vapor barrier
7. Vapor retarder
8. Waterstop
9. Joint Fillers

B. Samples

Submit samples of the following items

1. Vapor Barrier
2. Vapor Retarder
3. Beam clips
4. Waterstop

C. Concrete Mix Design

Submit proposed concrete mix designs for each type of concrete as required in Part 2.03 of this Section for acceptance by the Engineer at least three weeks prior to the start of any concrete work. Reports shall be signed and sealed by a Professional Engineer licensed in the state of NY and experienced in the design and testing of concrete mixes. The reports shall be made on the mix design submittal form included at the end of this specification, or with a similar format.

1. Reports for each mix shall include:
 - a. Source and type of each cement, including results of chemical and physical tests, if requested by Engineer.
 - b. Complete identification of source of supply for each type of aggregate.
 - c. Results of tests of aggregates for compliance with specified requirements, if requested by Engineer.
 - d. Scale weight of each aggregate.
 - e. Absorbed water in each aggregate.
 - f. Brand, type and amount per cubic yard of each admixture used (including synthetic fiber reinforcement).
 - g. Amount of free water used per cubic yard.
 - h. Proportions of each material per cubic yard.
 - i. Gross weight per cubic foot.
 - j. Measured slump.
 - k. Water/cementitious materials ratio, by weight. Submit strength vs. water/cementitious materials ratio curve based upon compressive tests, and indicating water/cementitious materials ratio to be used.
 - l. Total air content, by percent.
 - m. Water soluble ion chloride content, percent by weight of cement, if maximum is specified in this Section.
 - n. Compressive strength at seven and 28 days, from not less than two cylinders at seven days and not less than four at 28 days, for at least four different water/cement ratios.
 - o. Complete standard deviation analysis or trial mix test data.
 - p. For mixes with a design strength of more than 4 ksi, results of at least 4 cement cube strength tests.

2. If requested by Engineer, submit manufacturer or supplier's certificates of conformance to applicable standards for each ingredient.

D. Deviations

Requests for deviations from the Drawings or Specifications shall be submitted on Contractor's letterhead. Acceptance of shop drawings including deviations not detected during shop drawing review will not relieve Contractor from responsibility to conform strictly to the Contract Documents. Deviations will be allowed only where permitted by Engineer in writing. Proposed deviations must be accompanied by documented and physical evidence, which will establish that its quality equals or exceeds the quality specified.

E. Protective Measures

Submit hot and cold weather concreting procedures prior to start of any work. Including cold weather heating systems, enclosures, insulation, curing procedures and the like. Procedures shall be reviewed at a preconstruction conference.

F. Quality Control Submittals

1. Certificates

- a. Building Department form TR3, signed and sealed by the licensed concrete laboratory and concrete producer.
- b. Admixture manufacturer's certificate stating that the chloride content of the admixture will not exceed 0.05% by weight.
- c. Concrete laboratory license number and certification of meeting ASTM E329 standards.
- d. Concrete producer's certificate stating the plant and trucks are NYSDOT approved.
- e. Concrete producer's Computer Batch Ticket in accordance with Section BC 1905.8.2 of the 2014 NYC Building Code must be presented at site before concrete is placed for every load of concrete delivered.

2. Manufactures' Instructions

Waterstop manufacturer's instructions for proper installation of waterstop, including manner in which splices are to be made.

3. Contractor Qualifications

Provide proof of Installer and Producer qualifications specified under "Quality Assurance".

H. Survey

Submit signed and sealed copies of surveys conducted by a Licensed Land Surveyor showing elevations of all finished slab surfaces.

I. Mock-up

Provide mock-up as indicated under Quality Assurance.

F. Sustainable Submittals:

1. Submit Contractor's Sustainable Materials Form with complete information on recycled content for cementitious materials provided under the work of this section in accordance with Section S01352, Sustainability Requirements. Include cost of cementitious materials and percentage, by weight, of cementitious materials that have post-consumer or pre-consumer recycled content.
2. Submit documentation of recycled content in cementitious materials – product data, mix design information, or manufacturer's statement.
3. Submit Contractor's Sustainable Materials Form with complete information on regional content for concrete provided under the work of this section in accordance with Section S01352, Sustainability Requirements. Include cost of all concrete materials and distance in miles to point of materials extraction and manufacture.
4. Submit documentation of regional materials – product data, mix design information, or manufacturer's statement.

1.9 QUALITY ASSURANCE

A. General

Contractor shall examine all Contract Documents and note any discrepancies or items requiring close coordination or time schedules; assume responsibility of same and administer action such that the proper solution will result.

1. Contractor's material control procedures shall be effective and shall assure that all work fulfills the requirements of applicable provisions of the Contract Documents.
2. Contractor shall maintain sufficient staff to assure that all data and drawings for work of other sections is transmitted to detailers to allow proper detailing of holes, penetrations and the like and to assure proper execution of the work in the field.
3. Perform quality control functions required to achieve and to document that work conforms to the Contract Documents. Provide a reasonable number of copies of quality control reports and make all documents available up on request to the Architect, Owner and Engineer.
4. Contractor and Construction Manager shall coordinate and schedule the work of this section with the work of other sections of this specification in order to optimize quality and to avoid delay in job progress.
5. Prior to starting work the contractor shall cooperate and coordinate with each trade affected by the work of this section. Contractor shall report unsatisfactory or nonconforming conditions to the Engineer in writing prior to the start of work.
6. Construction loads shall not exceed the superimposed load which the member, with necessary supplemental support, is capable of carrying safely and without damage. The amount, method of distribution, and proposed supplemental support is the sole responsibility of the contractor.

B. Qualifications

1. General: Provide at least one person who shall be thoroughly familiar with the Construction Documents and other applicable requirements, trained and experienced in the necessary skills, and who shall be present at the site and direct all work performed under this section. Use an adequate number of skilled workmen to ensure installation in strict accordance with the approved design.
2. Concrete Installer: Company specializing in performing the Work of this Section shall have three years minimum experience on successful projects of similar size.
3. Concrete Producer: Company specializing in the production of concrete shall be certified by the National Ready Mixed Concrete Association (NRMCA) and shall have certification by either a New York City Agency or the NYS Department of Transportation. The plant shall use NYSDOT approved trucks and drivers shall be certified by the NRMCA.

4. Concrete Laboratory: Concrete laboratory providing design mixes shall be New York City licensed and shall meet the requirements of ASTM E329.

C. Regulatory Requirements

1. Building Code: Work of this Section shall conform to all requirements of the NYC Building Code and all applicable regulations of governmental authorities having jurisdiction including safety, health, noise, and anti-pollution regulations. Where more severe requirements than those contained in the Building Code are given in this Section, the requirements of this Section shall govern.
2. Industry Standards: The ACI Standards listed under references apply to Work of this Section. Where more severe requirements than those contained in the Standards are given in this Section or the Building Code, requirements of this Section or the Building Code shall govern. The Contractor shall keep a copy of ACI SP-15 - "Field Reference Manual" at the site.
3. Recommendations or suggestions in the codes and references listed in this Article and under "References" shall be deemed to be mandatory unless they are in violation of the Building Code.

D. Certifications

1. Cast-in-Place Concrete shall conform to the material acceptance, certification, and inspection requirements of Sections BC 1704.4 and BC 1905 of the 2014 NYC Building Code.
2. Cement and aggregate shall be acquired from the same source for all work. If a change in suppliers is required, a new mix submittal must be produced with the new material and submitted for approval.

E. Cold Weather

When casting concrete in cold weather, plans to protect the concrete shall be made in advance and in accordance with ACI306.1 and all necessary material and equipment shall be on site well in advance of concrete placement. The contractor is responsible for ensuring the proper planning for cold weather concreting.

F. Pre-Concrete Conference

At least 35 days prior to the start of the concrete construction schedule, conduct a meeting to review the proposed mix designs and to discuss the required methods and procedures to achieve the required concrete quality. The contractor shall send a pre-concrete conference agenda to all attendees 20 days prior to the scheduled date of the conference.

1.10 DELIVERY, STORAGE, AND HANDLING

- A. Materials and products shall be delivered to the site in the manufacturer's original and unopened containers and packaging bearing labels as to type of material, brand name and manufacturer's name. Delivered materials shall be identical to accepted samples.

- B. Materials and products shall be handled in a workmanship like manner per manufacturer's specifications. Storage shall be under cover in dry, weathertight, ventilated and clean locations off the ground.
- C. Storage of ingredients for concrete:
 - 1. Cement shall be stored in weathertight containers.
 - 2. Aggregate stockpiles shall be arranged and used in a manner to avoid excessive segregation and to prevent contamination with other materials or with other sizes of like aggregates. To ensure that this condition is met, any test for determining conformance to requirements for cleanliness and grading shall be performed on samples secured from the aggregates at the point of batching. Frozen or partially frozen aggregates shall not be used.
 - 3. Stockpiles of natural or manufactured sand shall be allowed to drain to ensure a relatively uniform moisture content throughout the stockpile.
 - 4. Unless predampening is not considered desirable by the manufacturer or is considered impractical by the Engineer, dry lightweight aggregates shall be predampened as necessary. To prevent excessive variations in moisture content, predampened aggregates shall be allowed to remain in the stockpiles for a minimum of 12 hours before use.
 - 5. Admixtures shall be stored in a manner that will avoid contamination, evaporation, or damage. For admixtures used in the form of suspensions or nonstable solutions, agitating equipment shall be provided to ensure thorough distribution of the ingredients. Liquid admixtures shall be protected from freezing and from temperature changes which would adversely affect their characteristics.
- D. Delivered materials which are damaged or otherwise not suitable for installation, shall be removed from the jobsite and replaced with acceptable materials.

1.11 ENVIRONMENTAL REQUIREMENTS

- A. Adequately protect concrete placed during rain, sleet, or snow, or when the mean daily temperature falls below 40°F or rises above 90°F as provided in Article 3.05.

1.12 PROJECT SITE CONDITIONS

- A. The Contractor shall report in writing to the Engineer any discrepancies between the design drawings and the existing site conditions.
- B. The Contractor shall field verify all information related to existing conditions such as: Surrounding structures, underground utilities and any other conditions that may exist.
- C. The Contractor shall survey surrounding structures to obtain information such as: Elevation of existing footings, bearing walls, water supply, sewage, utility piping and other utilities installations which may interfere with the construction.
- D. The Contractor shall obtain the pertaining information described above before starting a particular phase of work.
- E. Examine the substrata and the conditions under which the concrete is to be installed, and notify the Engineer in writing of unsatisfactory conditions. Do not proceed with the work until the unsatisfactory conditions have been corrected.
- F. All concrete work shall be properly protected during casting against freezing, excessive heat, acid rain or any other environmental destructive agent. Completed work shall be covered temporarily, permanently or as required. Protect adjacent finish materials against spatter during concrete placing.
- G. The Contractor shall comply with any and all federal, state and local environmental code requirements.
- H. Descriptions of, or limitations on, sequences of construction given in the Contract Documents are intended to assist the Contractor. Descriptions or limitations given are not by any means intended to fully describe construction limitations, sequence or techniques, nor preclude use of other methods if accepted by Engineer in writing. Whether or not Contractor follows the limitations and descriptions given herein, Contractor remains fully responsible for both the stability and the safety of the work; adherence to the limitations described herein does not relieve the Contractor from that responsibility.

1.13 DEFICIENT WORK

- A. Deficient work or any work failing to strictly conform to the Contract Documents shall be removed and replaced, or repaired if accepted by Engineer, at no cost to the Owner, Architect or Engineer.
 - 1. Contractor shall prepare appropriate details and procedures to bring such work into conformance with the Contract Documents and submit to Engineer for review and acceptance. Contractor shall, through the Owner, reimburse the Engineer for time and expense incurred reviewing proposal procedures and details in accordance with the Engineer's current fee schedule.
 - 2. Nonconforming work may be rejected by Owner, Architect or Engineer at any time, regardless of prior acceptance in shop drawings, prior inspection, inclusion in inspection or test reports, or inclusions in certificates of payments.

- B. Deficient work shall include, but not be limited to:
1. Low cylinder strength, as defined by this Specification.
 2. Excessive or deficient air content.
 3. Slump not in accordance with this Specification.
 4. Spalling, honeycombing, surface defects, cracking, improper consolidation or the like.
 5. Unauthorized cutting, construction joints, cold joints and so forth.
 6. Workmanship not in accordance with the Drawings, with this Specification, with accepted samples, or with referenced codes or standards.
 7. Incorrect forming, finishing or treating of concrete surfaces.
 8. Exceedance of tolerances.
 9. Evidence of improper curing and the like.
 10. Higher than specified water content and/or w/cm ratio as determined by Microwave testing.

PART 2 - PRODUCTS

2.1 MANUFACTURERS

- A. Lightweight Aggregate
1. Northeast Solite Corporation,
 2. Norlite Corporation,
- B. Admixtures
1. Euclid Chemical Company, Cleveland, OH 44110
 2. Master Builders,
 3. Sika Chemical Corporation,
 4. Anti Hydro Company,
 5. Chem Masters,
 6. W.R. Grace & Co.,
 7. St. Lawrence Cement Company,

8. BASF
- C. Curing Compounds
1. Euclid Chemical Company, Cleveland, OH 44110
 2. Master Builders,
- D. Waterstops
1. BBZ USA-Greenstreak, St. Louis, MO 63122
 2. Sika Corp, Lyndhurst NJ 07071
 3. DeNeef Construction Chemicals, Waller, TX 77484
- E. Vapor Barrier
1. Stego Industries, San Juan Capistrano, CA 92675
 2. Reef Industries, Houston, TX 77075
 3. W.R. Meadows, Hampshire, IL 60140-0338
- F. Vapor Retarder
1. Stego Industries, San Juan Capistrano, CA 92675
 2. Reef Industries, Houston, TX 77075
 3. W.R. Meadows, Hampshire, IL 60140-0338
- G. Bonding Agent
1. Sto Concrete Restoration Division, Atlanta GA
 2. Sika Corp, Lyndhurst NJ
 3. Euclid Chemical Company, Cleveland, OH 44110
- H. Densifier/Sealer
1. Euclid Chemical Company, Cleveland, OH 44110
 2. Curecrete Chemical Company, Inc., Springville, UT 84663

2.2 MATERIALS

A. Cement

Shall conform to ASTM C150 and shall be of the non air-entrained types, from a single supplier:

1. Unless otherwise specified or approved by the Engineer of Record, cement shall be Type I or II.
2. Type II shall be used for exterior pavements.
3. Cement shall not contain ingredients that would result in more than two percent air being entrained in the concrete.
4. For concrete mixes with a design strength of more than 4ksi, cement shall have a minimum 28 day cube strength of 4000 psi when tested in accordance with ASTM C109.

B. Admixtures

1. General

- a. The use of admixtures shall comply with the requirements of Section BC 1903.6 of the 2014 NYC Building Code.
- b. The final soluble chloride content in concrete, percent by weight of cement, due to the addition of admixtures and other ingredients shall not exceed 0.05 at 28 days. All admixtures shall be non-corrosive.
- c. The amount of cement required by the Building Code may be reduced by 40% as per the code with the use of slag cement that has been reviewed and approved by the Owner/Developer.
- d. All admixtures shall be added at separate intervals of the mix cycle.

2. Air-entraining admixture: Shall conform to ASTM C260.

3. Water-reducing admixture: Shall conform to ASTM C494, Type A or D, and contain no more chloride ions than found in drinking water.

4. High range, water-reducing admixture (super- plasticizer): Shall conform to ASTM C494, Type F or G, and contain no more chloride ions than found in drinking water.

5. Water reducing, accelerating admixture: Shall conform to ASTM 494, Type C or E, and contain no more chloride ions than found in drinking water.

6. Water reducing, retarding admixture: Shall conform to ASTM C494, Type D, and contain no more chloride ions than found in drinking water.

7. Slag cement: ASTM C989, Grade 100 or 120. Shall be GranCem slag cement as manufactured by the St. Lawrence Cement Company.
8. Fly Ash: ASTM C618, Class F except that maximum carbon content shall not exceed three percent and maximum percentage retained on the #325 screen shall not exceed 25 percent. Fly ash shall be from a single, domestic source.
9. Corrosion inhibiting, calcium nitrite based compound; "Eucon CIA" by the Euclid Chemical Company, "DCI Corrosion Inhibitor" by W.R. Grace & Co., "Rheocrete CNI" by BASF Admixture Systems.
10. Microsilica; "MSA" by the Euclid Chemical Company, "Force 10,000" by W.R. Grace & Co., or "Rheomac SF" by BASF Admixture Systems.

C. Water

Shall be clean potable water free of injurious foreign matter conforming to the requirements of Section BC 1903.4 of the Building Code.

D. Aggregates

Fine and coarse aggregates shall be regarded as separate ingredients. Each size of coarse aggregate, as well as the combination of sizes when two or more are used, shall conform to the appropriate grading requirements of the applicable ASTM specifications. Maximum size of coarse aggregate shall conform to paragraph 3.3.2 of ACI 318.

1. Aggregates for normal weight concrete shall conform to ASTM C33 and be of Size No.67 and/or No.8.
2. Aggregates for lightweight concrete shall conform to ASTM C330 and be of sizes 3/4" to No.4, 1/2" to No.4, and/or 3/8" to No.8. Lightweight coarse aggregate shall be rotary kiln product of expanded shale or slate and conforming to the requirements for normal weight coarse aggregates.
3. Fine aggregate shall be clean, hard, light colored sand.
4. Pea gravel aggregate shall be as given above except coarse aggregate shall be ASTM C33 size #8.
5. Aggregates for slab on ground shall conform to the recommendations of ACI 302.1R Chapter 4.

E. Curing Compounds

1. Non-strippable
 - a. Clear Curing and Sealing Compound (A.I.M. Regulations - VOC Compliant, 350 g/l): Liquid type membrane-forming curing compound, clear styrene acrylate type, complying with ASTM C1315, Type I, Class A, 25% solids content minimum. Moisture loss shall be not more than

0.40 Kg/m² when applied at 300 sq. ft./gal. Manufacturer's certification is required.

- b. Curing Compounds shall be "Super Diamond Clear VOX" by The Euclid Chemical Company or "Masterkure 100W" by Master Builders.

2. Strippable

- a. Clear Curing Compound: Liquid type membrane-forming curing compound, complying with ASTM C309.
- b. Curing Compounds shall be "Kurez DR Vox, Kurez W Vox by The Euclid Chemical Company or "Masterkure N-Seal VOC" by Master Builders.

F. Curing Materials

Sheet materials shall conform to ASTM C171 and be non-bleeding and non-staining. Burlap cloth shall be made from jute or kraft and conform to AASHTO M182, using at least 2 layers.

G. Bonding Agent

- 1. Epoxy/acrylic resin that will not form a vapor barrier with the concrete with the following properties:
 - a. Bond strength of 1800 psi in 2 hours when tested in accordance with ASTM C882.
 - b. Flexural strength of 2000 psi in 28 days when tested in accordance with ASTM C78.
 - c. Tensile strength of 600 psi in 28 days when tested in accordance with ASTM C496.
- 2. Bonding agent shall be "CR246 Sto Bonding and Anti-corrosion Agent" by Sto Concrete Restoration Division, Armatec 110 by Sika Corp, Corr-bond by Euclid Chemical Company, SBR Latex by Euclid Chemical Company, Daraweld-C by W.R. Grace & Co. or equivalent accepted by Engineer.

H. Densifier/Sealer

- 1. The densifier/sealer compound shall be a VOC compliant, non-yellowing, silicate-based sealer that penetrates concrete surfaces and increases abrasion resistance and provides a "low-sheen" surface that is easy to clean. The compound shall contain a minimum solids content of 20%, of which 50% is silicate.
- 2. Densifier/Sealer shall be "Euco Diamond Hard" by The Euclid Chemical Co. or "Ashford Formula" by Curecrete Chemical Co.

I. Vapor Barrier

1. Vapor Barrier shall meet the following properties:
 - a. Minimum 15-mil polyolefin geomembrane.
 - b. Water Vapor Barrier – ASTM E1745, Class A
 - c. Permeance Rating – ASTM E1745/E96 or E1249/E96: 0.018 perms or lower
 - d. Puncture Resistance by ASTM E1745: Class A, minimum 2300 grams
 - e. Tensile Strength by ASTM E1745: Class A, minimum 45 lbf/in
2. Accessories
 - a. High density polyethylene tape with pressure sensitive adhesive
 - b. Pipe boot for piping and conduits constructed from vapor barrier and tape
3. Shall be:
 - a. Stego Wrap 15 mil Vapor Barrier by Stego Industries
 - b. Griffolyn 15 mil Green by Reef Industries
 - c. Perminator 15 mil by W.R. Meadows

J. Vapor Retarder

1. Vapor retarder shall be polyolefin type material, 10-mil thick minimum, with a perm rating of less than 0.1 when tested in accordance with ASTM E1745/E96, procedure A, and shall be resistant to decay when tested in accordance with ASTM E154 and meet ASTM E1745 Class A.
2. Shall be:
 1. Griffolyn 10 mil Green by Reef Industries
 2. Stego Wrap 10 mil Vapor Retarder by Stego Industries
 3. Perminator 15 mil by W.R. Meadows

K. Waterstops

1. Concrete Joints
 - a. Water-swelling acrylate ester resin, hydrophilic rubber, or polyurethane type capable of expanding and contracting over multiple number of wet-

dry cycles without reduction in its expansion ratio. If concrete surface is very uneven, provide paste type indicated in 2 below.

- b. Shall be Duroseal Gasket Waterstop by BBZ USA-Greenstreak, Swellseal 8 by DeNeef, SikaSwell Profile by Sika Corp., or Waterstop-RX by Volclay Provide approximately 1" x 3/4" chemical resistant type. Attach to concrete and membranes with manufacturer's recommended adhesive or paste type waterproofing.
- c. PVC type shall be 6" wide dumbbell or serrated type made from virgin PVC; Style 748 or 679 by Greenstreak, Type R6-316 by Vinylex, or equivalent accepted by Engineer.

2. Steel, pipe and metal penetrations

- a. Water-swelling acrylate ester or polyurethane paste type capable of expanding and contracting over multiple number of wet-dry cycles without reduction in its expansion ratio. Paste is a thixotropic grade material capable of being placed on uneven surfaces.
- b. Shall be Duroseal Paste by BBZ USA, Swellseal Mastic by DeNeef, or SikaSwell S by Sika Corp. Provide chemical resistant type. Provide a minimum of 3/8" by 1/2" bead of material.

L. Reed Clips for Concrete Encased Structural Steel

1. Expandible reed clips shall consist of 12-gage longitudinal wires and 12-gage clips 9" on center, which place the wires 3/4" to 1" from the flanges.
2. Provide the following types, depending on member sizes:
 - a. 4" wide, expandible to 8"
 - b. 8" wide, expandible to 12"
 - c. 12" wide, expandible to 16"
 - d. 16" wide, expandible to 24"
3. Shall be Expandible Reed Clips by Equipment Distributing Corporation.

M. Granular Fill

Under slabs on ground shall be well a graded run of bank sand and gravel with maximum size of 1-1/2", between 30% and 50% passing a #4 sieve, between 10% and 25% passing a #50 sieve and not more than 5% of particles by weight passing a #200 sieve. Imported material, if required, shall consist of a well graded mixture of sand and durable, hard limestone. The Contractor shall provide laboratory gradation tests (i.e., before and after laboratory compaction tests) and compaction tests (ASTM D 1557) prior to delivery for evaluation and approval by the geotechnical engineer.

N. Gravel or Crushed Stone

Under slabs on ground shall be hard, clean, natural rock, free of dust or other contaminants, and graded to requirements of ASTM C33, size #67.

O. Bond Breaker

Under fill and topping slabs shall be 4 mil thick polyethylene sheet.

P. Styrofoam

Shall conform to ASTM C578, Type VI; Styrofoam 40 High Load by the Dow Chemical Company or equivalent approved by the engineer.

Q. Expansion Dowels

ASTM A36 bars, hot-dipped galvanized and provided with a suitable expansion shield securely positioned and end filled with a readily compressible material assuring adequate expansion space beyond.

R. Neoprene Pads

Shall conform to AASHTO Standard Specification, Division II, Chapter 18 ASTM D2240, grade 50 Durometer hardness.

S. Premolded Joint Filler

Non-extruding bituminous-type preformed expansion joint filler conforming to ASTM D1751.

U. Semi Rigid Joint Filler

For contraction and construction joints in slabs on grade a two (2) component 100% solids compound, with a minimum shore A hardness of 80. Provide "Euco 700" or "QWIKjoint 200" by The Euclid Chemical Company or Masterfill CJ by BASF Admixture Systems.

V. Penetrating Sealer

Clear solvent based or water based silane or siloxane penetrating sealer; Euco-Guard 100, 200 or Vox by the Euclid Chemical Company, Sikaguard 701W by Sika, Masterseal SL by BASF Admixture Systems, or equivalent accepted by Engineer.

W. Polymer Repair Mortar

Polymer and microsilica modified cementitious based compound; "Thin Top Supreme, Concrete Top Supreme" (Horizontal repairs) by the Euclid Chemical or "Sikatop 121 or 122" (Horizontal repairs) by Sika Chemical, or "Verticoat/Verticoat Supreme by The Euclid Chemical Company (Vertical or Overhead) or "Sika 123" by Sika Chemical (Vertical or Overhead) by Sika Chemical. These patching mortars may be used when color match of the adjacent concrete is not required. Prior approval by the Engineer is required.

X. High Strength Repair Mortar

A flowable high strength, microsilica modified repair mortar for large horizontal placements or form and pour applications; Eucocrete by Euclid Chemical.

Y. Underlayment Compound

Free flowing, self-leveling, pumpable cementitious base compound, Flo-Top or Super Flo-Top by The Euclid Chemical Company, Ardex by Ardex Company, or Underlayment 110, by BASF Admixture Systems.

2.3 MIXES

A. General

1. Contractor shall employ a consultant, acceptable to the Engineer, hereinafter called the "Concrete Consultant", to prepare concrete mix designs from representative samples of the materials to be used to produce the concrete for each "type" of concrete required. A new "type" of concrete exists whenever there are changes to source or type of ingredient, source or type of cement, design strength, proportioning, or placing methods.
2. The Concrete Consultant shall design or verify mixes for each "type" of concrete in accordance with the trial mixture method or field experience method of ACI 318 Article 5.3. Test results of trial mixes shall be submitted to Engineer for acceptance prior to concreting. Each mix shall clearly state the location where mix is to be used.
3. The proportion of ingredients shall be selected by the Concrete Consultant to produce proper placeability, durability, strength, and to produce a mixture which will work readily into the corners and angles of forms and around reinforcement by methods of placement and consolidation employed on the work, but without permitting materials to segregate or permitting excessive free water to collect on surface. Comply with recommendations of ACI 211.1, 211.2 and 302.1R.
4. When a source, type, kind or brand of each constituent has been established and approved for the project mixes, it shall not be changed throughout the duration of the concreting. Batch all constituents including admixtures at the central batch plant.

B. Method of Proportioning

1. Proportion, batch, and mix concrete in accordance with Section BC 1905. The licensed concrete laboratory is responsible running the mix and signing the TR3 for filing with the Building Department. Proportion concrete mix in accordance with Section BC 1905.3.
2. Mix designs are specific to material used, concrete producer, and method of placement. Each mix design must be reviewed by the Engineer of Record and accepted prior to placement along with accompanying TR3 signed by the lab and concrete producer.
3. The recycled content in the concrete mix shall be 40% of the cementitious content or a minimum of 6% of the dry weight.

C. General Mix Requirements

1. Concrete mixes shall be designed to provide for all of the requirements given in this Specification and on the Drawings even if strength or any other criteria must be exceeded to meet another criteria.
2. Strength requirements given on the Drawings shall be based on 28-day compressive strength (56 days for concrete containing 40% alternate cementitious material - slag) for Type I and II cement and 7-day for Type III, unless a different test age is specified.
3. Concrete to be exposed to deicing salts, to brackish water, or to salt laden air in service shall have a maximum water-to-cement ratio, by weight, of 0.40, a minimum strength of 5000 psi, a minimum cement content of 650 pounds per cubic yard, air entrainment, Type II cement, and a maximum water soluble chloride ion content of 0.15 percent by weight of cement.
4. All concrete required to be watertight shall have a maximum water-to-cement ratio, by weight, of 0.40 and a minimum strength of 5000 psi.
5. Provide pea gravel aggregate concrete for all sections thinner than 6 inches, and where required due to congestion of reinforcing steel.
6. Concrete mixes to be exposed to earth or weather shall have a maximum water soluble chloride ion content of 0.30 percent by weight of cement.
7. All normal weight concrete subject to freezing and thawing shall contain 4½% minimum to 6 1/2% maximum total air content. The allowable tolerance shall be plus or minus 1 ½% of the air content indicated in the mix design.

D. Normal Weight Concrete

1. Unless otherwise specified, proportion and produce normal weight concrete to have a maximum slump of 4" or less. A tolerance of up to 1" above the indicated maximum shall be allowed for individual batches provided the average for all batches or the most recent 10 batches tested, whichever is fewer, does not exceed the maximum limit. The slump shall be determined by ASTM C143. Concrete containing High Range Water Reducer shall have a slump not exceeding 9", unless otherwise approved by the Engineer of Record. The concrete shall arrive at the job site at a slump of 2" to 3", be verified, and the HRWR admixture added to increase the slump to the approved level.
2. All normal weight concrete subject to freezing and thawing shall be air-entrained, provide the following air content for the grading size of coarse aggregate as follows:
 - a. No.8.....7½%
 - b. No.67.....6%

Tolerance on air content as delivered shall be +1.5%.

3. Normal weight concrete shall have a maximum water-to-cement ratio, by weight, of 0.40 and a minimum strength of 5,000 psi unless otherwise noted.

E. Admixtures

1. Concrete mixes with admixture dosages exceeding 64 ounces per cubic yard of concrete shall have free water content of concrete mix reduced by aqueous portion of admixtures in order to adhere to water to cementitious ratio requirements.
2. A water reducing admixture or high-range water reducing admixture shall be used in all mix designs.
3. A high range, water reducing admixture shall be used when any of the conditions below apply. Self-Consolidating concrete shall have a slump/flow of 20" to 30".
 - a. Water to cementitious ratio is 0.45 or less, architectural concrete, self-consolidating concrete, and synthetic fiber concrete.
 - b. Concrete is to be pumped.
 - c. When requested by the Contractor and accepted by the Engineer in concrete mix design.
4. An air-entraining admixture shall be used in all mix designs for concrete subject to freezing and thawing.
5. A water reducing, retarding admixture shall be used when concrete is to be placed during hot weather as defined by ACI 305R.
6. Fly ash shall be used as an admixture for all lightweight concrete to be pumped.
7. A non-corrosive accelerator shall be used when concrete is to be placed during cold weather as defined by ACI 306.1.
8. Synthetic macro fiber reinforcement shall be used where called for on the Drawings and when requested by Contractor and accepted by the Engineer. Unless noted otherwise on the Drawings, or otherwise recommended by the manufacturer, dosage rate shall be 1-1/4 pounds per cubic yard.

2.4 SOURCE QUALITY CONTROL

A. Tests

1. The Owner/Developer's Testing Laboratory will review and/or check test proposed materials for compliance with the Specifications prior to construction.
2. The Testing Laboratory will perform field tests as work progresses as listed in "Field Quality Control".

B. Inspection

1. Testing Laboratory

a. The Owner/Developer will engage a Licensed Concrete Testing Laboratory, meeting the requirements of ASTM C1077 and ASTM E329, to inspect batching of the concrete, at the Authorities discretion, and perform all field tests. The Laboratory will perform the following services:

- 1) Review and/or check-test the Contractor's proposed materials for compliance with the Specifications.
- 2) Review and/or check-test the Contractor's proposed mix design.
- 3) Secure production samples of materials at plants or stock-piles during the course of the Work and test for compliance with the Specifications.
- 4) Perform tests during construction as required by Section BC 1905.6.2 of the 2014 NYC Building Code. The Laboratory will obtain samples at the mixer and when directed by the Engineer at the point of placement by the following methods:
 - a) Secure composite samples in accordance with ASTM C172. Each sample shall be obtained from a different batch of concrete on a random basis, avoiding any selection of the test batch other than by a number selected at random before commencement of concrete placement.
 - b) Mold and cure specimens from each sample in accordance with ASTM C31 and perform strength tests.

b. The Owner/Developer may assign a qualified concrete technician to be stationed at the batch plant depending on the size of the project or evidence of poor concrete breaks. At least one qualified concrete technician will be stationed at the site to obtain the test specimens.

c. The Laboratory will be responsible to and under the supervision of the Special Inspector.

2. Special Inspector

a. The Owner/Developer will assign, under the requirements of Section BC 1704.4 a Special Inspector who will supervise the testing of the materials and the inspection of concrete construction. The Special Inspector is responsible for any required filing with the Building Department, as well as maintaining a log book of the concrete work.

- b. The Special Inspector will check that all required tests are made and the results submitted and shall have the right to order the Contractor to make such changes of the mix of concrete as required to produce concrete of the necessary strength provided that it satisfies the drawings, specifications and building code. Any changes to the mix shall be submitted to the engineer for approval. The Special Inspector will also report to the Building Department Superintendent any deviation from the requirements of the Code, as indicated by records of inspection and reports of tests.

3. Notifications

- a. Notify the Owner/Developer in writing at least forty-eight hours in advance of each concrete placement. The Owner/Developer will notify the Testing Laboratory immediately to order out the necessary concrete technicians to cover the work.
- b. Once the concrete technicians are ordered out and a cancellation follows, the Contractor will be charged Four Hundred Fifty Dollars for each technician so ordered to appear, unless a cancellation order is issued to the Laboratory by 3 PM the day before the concrete placement.
- c. During the placement of the concrete, notify the Owner/Developer immediately of any delay at the concrete plant or at the job site. Where the Owner/Developer decides to provide a technician at the plant, do not mix concrete or add admixtures unless the Technician is present. Do not add admixtures to be added at the site unless the Technician is present.
- d. The Testing Agency shall report directly to the Owner/Developer and Engineer the results of all testing and inspection by means of daily written reports. When any test or inspection reveals deficient or nonconforming work the Testing Agency shall notify the Owner/Developer and Engineer immediately by means of a written report specially and clearly marked and identified to show deficient areas of work.

4. Contractors Responsibility for Quality Control

- a. The Contractor will receive a copy of all reports prepared by the Laboratory and/or Special Inspector. Copies of the daily concrete reports prepared by the Special Inspector will be available for reference.
- b. The Contractor will therefore be afforded an opportunity to review all reports and mix data and submit to the Special Inspector and Engineer any recommendations in changing the mixes provided they conform to the Code and Specifications. Any testing required because of changes in materials or proportions of the mix requested by the Contractor, as well as any extra testing of concrete or materials occasioned by the failure to meet Specification requirements shall be at the Contractor's expense. The Contractor, at any time, can arrange to have independent tests made at own expense by an approved laboratory and submit the reports and recommendations to the Special Inspector and Engineer of Record.

- c. The tests and inspections or waiving of tests and inspections by testing agency, as provided in the Code, do not in any way relieve the Contractor of responsibility to construct the Work in accordance with the Drawings and Specifications and to use safe, standard methods of construction at all times, safeguarding the public, workmen, and structure. The Contractor shall be solely responsible for the physical control of the materials and concrete mixes, and shall see that such mix designs, tests, and controls are in accordance with the Code and Specifications.
- d. It shall be the Contractor's complete responsibility to adjust, alter, and/or correct any controls necessary in materials and/or concrete operation based upon tests and inspections made by the Owner/Developer or the Contractor's independent tests. If, during the course of the concrete operations, a lower water content or more cement is needed per cubic yard above that used in the approved design mix, provide same at no additional cost to the Owner/Developer.
- e. If the Contractor requests any deviation from the Specifications and Drawings, or makes or causes to be made any change of construction from Drawings and Specifications, and such request requires the time and investigation of the Engineer of Record, pay all costs incurred by the Owner/Developer relating to such time and investigation.
- f. Where additional tests are deemed necessary by Engineer due to failure to pass tests, the cost of additional testing will be deducted from payments to Contractor.
- g. If, due to errors by the contractor or failure to perform his work in accordance with the Contract Documents, the Engineer must perform additional design or drafting work or review proposed solutions, the Contractor shall, through the Owner, reimburse the Engineer in accordance with the Engineer's current fee schedule, plus out of pocket expenses incurred.

PART 3 - EXECUTION

3.1 EXAMINATION

- A. Prior to placement of concrete, verify that the concrete cover over the reinforcement is that specified on Drawings.
- B. Verify that anchor bolts, reinforcement, and all other embedded items are provided and held securely, positioned accurately, and will not be a detriment to concrete placement.
- C. Examine all adjoining work on which this Work is in anyway dependent for proper installation and workmanship. Report to the Engineer and Owner/Developer any condition that prevents the performance of this Work.

3.2 PROTECTION

- A. Protect concrete members on grade and the subgrade from freezing before and after installation. Provide blankets and other items necessary.
- B. Protect adjacent finish materials and previously poured concrete against spatter during concrete placement.
- C. Provide and maintain barricades and safeguards around openings, etc. to protect workmen from injury and to comply with all Building Code, OSHA, and other authorities having jurisdiction regulations.

3.3 PREPARATION

- A. Remove ice, excess water, trash, and rubbish from forms.
- B. Remove hardened concrete from inner surfaces of conveying equipment and all formwork, reinforcement, and dowels.
- C. Prepare previously placed concrete to be in contact with new concrete in the manner described under "Construction Joints".
- D. Prepare existing concrete to be in contact with new concrete by roughening and cleaning the surface and applying a bonding agent. Surface must be free of laitance. Concrete must be placed after agent cures and within 20 hours of applying bonding agent. If time elapses, apply a new application in accordance with the directions of the manufacturer.
- E. In case a conflict arises between concrete as poured and other Work that requires cutting into concrete beams, columns, walls, or slabs, submit requests to the Engineer of Record, who will issue instructions accordingly. Cutting of concrete is otherwise prohibited.
- F. Do not place concrete on frozen ground.
- G. Contractor is solely responsible for the protection, shoring, bracing, stability and underpinning of existing structures either on or adjacent to the site. Details and extent of such work shown on the Drawings are suggestions only; Contractor is to determine requirements and methods. All of the above operations shall be done under the supervision of a qualified Professional Engineer licensed in the state of NY.
- H. Contractor shall examine all existing surfaces, structures and the like which the work must attach to, clear or abut. Notify Engineer in writing of any conditions, which will delay or be detrimental to work. Start of work shall represent acceptance by Contractor of existing conditions as suitable for completing work as specified.
- I. Contractor shall verify, by measurements at the site, all existing dimensions, which affect the work of this Section. Field dimensions varying from those on the design drawings or accepted shop drawings shall be brought to the Architect's and Engineer's attention in writing.

3.4 JOINTS AND EMBEDDED ITEMS

A. Construction Joints

1. Shall be made and located only as shown or indicated on the Drawings or accepted shop drawings. Conform to ACI 318, Article 6.4. All construction joints not shown or indicated on the Drawings shall be submitted in writing for acceptance.
2. Place construction joints perpendicular to main reinforcement and continue reinforcement across joints. Provide longitudinal keys at least 1¹/₂" deep in walls, slabs and between walls and footings. Accepted bulkhead designs for this purpose may be used for slabs. Drawings indicate keys or roughened surface at interface of walls and footings.
3. Use butt joints for unreinforced slabs on grade with Diamond Dowels for proper load transfer.
4. Thoroughly clean concrete surface of oil, grease, and other contaminants and remove all laitance prior to placement of adjoining concrete. Roughen surface of the concrete in an approved manner that will expose the aggregate uniformly to a 1/4" amplitude and will not leave laitance, loosened particles of aggregate, or damaged concrete at the surface. Dampen surface immediately prior to placement.
5. Provide waterstops in construction joints as indicated on drawings and specifications. Install waterstops to form continuous diaphragm in each joint. Make provisions to support and protect exposed waterstops during the progress of work. Fabricate field joints in waterstops in accordance with manufacturer's instructions.
6. Where overlay finishes, such as pavers or terrazzo, are to be provided, locate construction joints accurately below or behind expansion joints in the finish material.
7. Do not exceed maximum distance between construction joints noted in the Drawings or this Specification. If no criteria is given, do not space greater than 40 feet for walls, 100 feet in any direction for formed slabs, or 40 feet for slabs on ground.
8. Do not cast columns higher than 1/2 inch or lower than 1 inch below lowest girder, beam or slab supported by the column.
9. Construction joints designated to be specially roughened, or joints of new concrete connecting to existing concrete, shall be bush hammered to 1/4-inch minimum roughness amplitude and thoroughly cleaned. Apply specified bonding agent where noted or specified.
10. Joints in slabs on grade, subjected to hard wheeled traffic shall be filled with the specified semi-rigid joint filler. The installation shall be made in strict accordance with the instructions from the manufacturer. The surface must be level with the concrete shoulders.

11. Properly install all embedded items where required.
12. Construction joints shall be made in accordance with Section BC 1906.8 of the Building Code.

B. Expansion Joints

1. Do not extend reinforcement or other embedded metal items bonded to concrete continuously through expansion joint and keep joint free of all other materials. Provide smooth dowels greased on one end at the joints with end cap or insert into pvc sleeve of length greater than the dowel length by .75" minimum.
2. Provide joint filler of type specified in Section 07900 at the expansion joint of the sizes indicated on the Drawings or specified herein.

C. Contraction (Control) Joints in Slabs-On-Ground

1. Construct in pattern as shown or noted on Drawings.
2. Inserts shall be laid into fresh concrete until top surface of strip is flush with slab surface. Tool slab edges round on each side of inserts. After concrete has cured, remove inserts and clean groove of loose debris.
3. Saw cuts shall be made as soon as possible after slab finishing and may be done without dislodging aggregate.
 - a. Maximum joint spacing shall be 36 times the slab thickness unless otherwise noted on the drawings. The Soff-Cut saw shall be used immediately after final finishing and to a depth of 1 1/4". A conventional saw shall be used as soon as possible without dislodging aggregate and to a depth of 1/4 slab thickness.
 - b. Use load plate baskets under saw cuts where designated on the plans for load transfer.
4. Joints, in slabs on grade, subjected to hard wheeled traffic shall be filled with the specified semi-rigid joint filler. The installation shall be made in strict accordance with the instructions from the manufacturer. The surface must be level with the concrete shoulders.

D. Isolation Joints in Slabs On Ground

1. Provide at points of contact between slabs on ground and vertical surfaces where shown or called for on drawings. Provide joint filler and sealant as specified.

C. Waterstops

1. Provide waterstops at all joints and all penetrations of type indicated in Part 2 of this Section. All surfaces onto which material is placed shall be clean and smooth. Do not let materials come in contact with water by covering waterstop, forms, or other means necessary. Provide minimum clearance from edge of concrete as per manufacturer's recommendations, typically 3".
2. Provide maximum practical lengths for each piece so that the number of end joints will be held to a minimum.
3. Make joints in such a manner that they develop effective watertightness fully equal to that of the continuous material. All joints to be lapped as per manufacturer's instructions.
4. Use manufacturer's adhesive or swelling paste type for applying gasket type to previously poured concrete and/or waterproofing membrane. Surface onto which waterstop is placed shall be smooth.
5. Provide swelling paste type at all pipe penetrations, conduits, drains, steel members, and other areas where items penetrate the concrete foundation system and at uneven concrete surfaces.
6. If water penetrates joints in which waterstops are placed at contract locations or at cracks and cold joints, the Contractor shall remediate the crack with injection material recommended by the Owner/Developer and approved by the Engineer that will provide a 5-year labor and material guarantee against water seepage at no cost to the Owner/Developer.

D. Other embedded items

1. Place all fence sleeves and shoes, pipe sleeves, inserts, anchors, anchor bolts, and other embedded items required for the Work of other Divisions or for their support prior to concreting. Install Link-seal Watertight Sleeves by Thunderline Corp. through foundation walls and other locations where watertight construction is required and where indicated on Drawings as per manufacturer's instructions. Coordinate with other trades, all Drawings, and manufacturer for sizes, location, and quantity.
2. Provide ample notice and opportunity for items of other Division to be introduced and/or furnished for installation before concrete is placed. Coordinate the Work of the other Divisions so all items are placed in their proper location.
3. Set metal pipe sleeves, sockets, shoes, etc. into concrete to receive fence posts or any other items, all as indicated on details.

E. Placement of Embedded Items

Position expansion joint material, waterstops, and other embedded items accurately and support against displacement. Fill voids in sleeves, anchor slots, and inserts temporarily with readily removable material to prevent the entry of concrete into the voids.

3.5 MIXING AND PLACING CONCRETE

A. General

1. Notify Owner/Developer at least 48 hours in advance of each concrete placement. Do not place concrete without approval of the Special Inspector.
2. Do not allow rainwater to increase mixing water nor damage surface finish.
3. When placing concrete in cold weather (air temperature below 40°F), concrete shall contain either an accelerating admixture or use Type III cement.

B. Mixing

1. Batch, mix, and transport ready-mixed concrete in accordance with the appropriate sections of ASTM C94 and Section BC 1905.8.2 of the 2014 NYC Building Code. Truck mixers and agitators shall meet the requirements of the Truck Mixers Manufacturer's Bureau or shall comply with Section 8.1.2 of ASTM C94 and shall be NYSDOT approved. All trucks shall have working revolution counters and site gages. Batch all other concretes in accordance with subsection 4.3.1 of ACI 301 only if permitted by the Engineer of Record and Special Inspector.
2. Batch ready-mixed concrete only in plants that are NRMCA certified and NYSDOT approved. Only plants that are NYSDOT approved with current certification meeting the requirements for certification of the NRMCA for automatic batching and automatic recording will be permitted. Concrete shall be batched by the use of automation.
3. Unless otherwise approved by the Engineer of Record, concrete shall be deposited within 1½ hours or 300 revolutions of the mixing drum, whichever comes first, after introduction of water to the cement or cement to the aggregate. When the ambient temperature rises above 90°F, the time shall be decreased to 1 hour.
4. Batch lightweight concrete using the saturated weight of aggregate, which shall take into account the internal and surface moisture content.
5. Tempering and control of mixing water
 - a. Mix concrete only in quantities for immediate use. Concrete that has started to set shall not be retempered, but shall be discarded. After the introduction of initial mixing water for the batch, no additional water shall be added at the site.
 - b. For concrete containing HRWR (Superplasticizer), if loss of slump occurs, HRWR may be redosed at the site as long as a "flash set" has not occurred. Redosage procedures must be discussed and approved by the Engineer and the admixture manufacturer at the Pre-Concrete Conference.

6. Weather Conditions

a. Cold weather (Air Temperatures below 40°F)

- 1) Concrete shall have either an accelerating admixture or use Type III cement. Do not use calcium chloride, salt, materials containing antifreeze agents or chemical accelerators, unless otherwise accepted in mix designs.
- 2) The temperature of concrete delivered at the site shall conform to the temperature limitations given in Section 5 of ACI 301.
- 3) If water or aggregate is heated above 100°F, combine the water with the aggregate in the mixer before cement is added. Cement shall not be mixed with water or with mixtures of water and aggregate having a temperature greater than 100°F.
- 4) Detailed requirements are given in ACI 306R.

b. Hot Weather (Air Temperatures above 90°F)

- 1) Cool the ingredients before mixing, or substitute flake ice or well-crushed ice of a size that will melt completely during mixing for all or part of the mixing water if, due to high temperature, low slump, flash set, or cold joints are encountered. Water equivalent of ice must be calculated to total amount of mixing water.
- 2) Detailed requirements are given in ACI 305.

7. Admixtures - General

- a. Add all admixtures prior to mixing unless otherwise specified or directed.
- b. Air-entraining admixtures and other chemical admixtures shall be charged into the mixer as solutions and shall be measured by means of an approved mechanical dispensing device. The liquid shall be considered a part of the mixing water. Admixtures that cannot be added in solution may be weighed or may be measured by volume if so recommended by the manufacturer. The accuracy of measurement of any admixture shall be within +3 percent.
- c. If two or more admixtures are used in the concrete, add them separately to avoid possible interaction that might interfere with the efficiency of either admixture or adversely affect the concrete. Do not charge admixtures into the mixer in such a manner that they will come in direct contact with the cement.
- d. Use of accelerating admixtures or Type III cement shall not relax cold weather placement requirements.

- e. Use of retarding admixtures in hot weather must be approved by the Special Inspector. Use of such admixtures will not relax hot weather placement requirements.
 - f. Where using high-range, water-reducing admixture shall be added at the jobsite or at the initial batching, in accordance with the manufacturer's instructions.
 - g. Where synthetic macro fiber reinforcement is used, fibers shall be added when concrete is batched. Follow manufacturer's instructions and standard ASTM C94 practices.
8. Hand-Mixed concrete shall not be used without written acceptance by Engineer. When permitted, such concrete shall be mixed only in watertight containers. Each ingredient shall be measured dry and sand and cement shall be mixed prior to adding coarse aggregate. Water shall be added slowly so as to provide an even mixture

C. Placing

- 1. General: Place concrete in accordance with ACI 304R, ACI309R ACI 318, and Sections BC 1905.9 and BC 1905.10 of the 2014 NYC Building Code.
 - a. Before placing concrete, inspect and complete formwork installation, reinforcing steel, and items to be embedded or cast in. Notify other trades to permit installation of their work; cooperate in setting such work. Moisten wood forms immediately before placing concrete where form coatings are not used.
 - b. Forms and other surfaces to receive fresh concrete shall be clean and free of frost, dirt and any other debris immediately prior to and during concrete placing.
 - c. Apply temporary protective covering to lower 2 feet of finished walls adjacent to poured floor slabs and similar conditions, and guard against spattering during placement.
- 2. Conveying
 - a. Handle concrete from the mixer to place of final deposit as rapidly as practicable by methods that will prevent separation or loss of ingredients and in a manner that will assure that the required quality of concrete is obtained.
 - b. Conveying equipment shall be approved and shall be of a size and design such that detectable setting of concrete shall not occur before adjacent concrete is placed. Conveying equipment shall be cleaned at the end of each operation or workday. Conveying equipment and operations shall conform to the following additional requirements:

- 1) Truck mixers, agitators, and non-agitating units and their manner of operation shall conform to the applicable requirements of ASTM C94.
 - 2) Belt conveyors shall be horizontal or at a slope which will not cause excessive segregation or loss of ingredients. Concrete shall be protected against undue drying or rise in temperature. An approved arrangement shall be used at the discharge end to prevent apparent segregation. Mortar shall not be allowed to adhere to the return length of the belt. Long runs shall be discharged into a hopper or through a baffle.
 - 3) Chutes shall be metal or metal-lined and shall have a slope not exceeding 1 vertical to 2 horizontal and not less than 1 vertical to 3 horizontal. Chutes more than 20' long and chutes not meeting the slope requirements may be used provided they discharge into a hopper before distribution.
 - 4) Pumping or pneumatic conveying equipment shall be of suitable kind with adequate pumping capacity. Pneumatic placement shall be controlled so that segregation is not apparent in the discharged concrete. The loss of slump in pumping or pneumatic conveying equipment shall not exceed 2". Pumping is permitted only if a pump mix is approved. Concrete shall not be conveyed through pipe made of aluminum or aluminum alloy.
3. Depositing: Detailed recommendations are given in ACI 304R.
- a. General
 - 1) Deposit concrete continuously, or in layers of such thickness that no concrete will be deposited on concrete that has hardened sufficiently to cause the formation of seams or planes of weakness within the section. If a section cannot be placed continuously, locate construction joints at points as provided for in the Drawings, shop drawings, or as approved. Should cold joints form, cease operations. Submit detailed drawings showing remedial measures for acceptance. Drilled dowels or anchors or chipped keyways may be required by the Engineer.
 - 2) Carry out placement at such a rate that the concrete that is being integrated with fresh concrete is still plastic. Do not deposit concrete that has partially hardened or has been contaminated by foreign material.
 - 3) Deposit concrete in forms in horizontal layers not deeper than 24" and in a manner to avoid inclined construction joints. Where placement consists of several layers, place each layer while preceding layer is still plastic to avoid cold joints.

- 3) Place concrete on metal deck in a manner that uniformly distributes the material over the metal deck in order to avoid overloading the deck joints.
 - 4) Remove temporary spreaders in forms when the concrete placing has reached an elevation rendering their service unnecessary. They may remain embedded in the concrete only if made of metal or concrete and if prior approval has been obtained.
 - 5) Placing of concrete in supported elements shall not be started until the concrete previously placed in columns and walls is no longer plastic.
 - 6) Deposit concrete as near as practical to its final location. Minimize lateral movement of fresh concrete. Placement procedures shall not allow concrete to drop thru successive reinforcing grids, nor strike cages in columns or layers in walls.
- b. Segregation: Deposit concrete as nearly as practicable in its final position to avoid segregation due to rehandling or flowing. Do not subject concrete to any procedure that will cause segregation. Free drop of concrete shall not exceed 8 feet for columns or 4 feet for other elements. Self-Consolidating Concrete may be dropped further when approved by the engineer. Canvas or rubber elephant trunks may be used to limit free drop.
- c. Consolidation
- 1) Consolidation of concrete and the use and type of concrete shall be in accordance with ACI 309R.
 - 2) Where a surface mortar is to be the basis of the finish, the coarse aggregate shall be worked back from the forms with a suitable tool so as to bring a full surface of mortar against the form, without the formation of excessive surface voids.
 - 3) Consolidate all concrete by vibration so that the concrete is thoroughly worked around the reinforcement, around embedded items and into corners of forms, eliminating all air or stone pocket or weakness. Internal vibrators shall be the largest size and most powerful that can be used in the Work, as described in Table 5.1.5 of ACI 309R, with a minimum frequency of 7000 revolutions per minute and shall be operated by competent workmen. Overvibrating and use of vibrators to transport concrete within forms is not permitted. Insert and withdraw vibrators at many points, from 18" to 30" apart. At each insertion, the duration shall be sufficient to consolidate the concrete but not sufficient to cause segregation, generally from 5 to 15 sec duration, and shall reach the bottom of the pour. Keep a spare vibrator on the job site during all concrete placing operations.

- 4) Self-Consolidating Concrete may not require vibration if successful placement is demonstrated on site.
4. Cold Weather Concrete Placement and Protection: Detailed requirements are given in ACI 306.

When the mean daily temperature of the atmosphere is less than 40°F during concreting, or within 72 hours there after (or the air temperature is not greater than 50°F for more than one-half of any 24-hr period for a period of 3 consecutive days), follow the procedures outlined in ACI 306R to protect the concrete. Provide a cold weather concreting plan as well as list of equipment and material (e.g. thermometers, blankets) to be used to the Special Inspector. Temperature of the plastic concrete shall be no lower than 55°F and not more than 80 °F at point of placement. Heat all forms, reinforcing steel, subgrades and surfaces to receive concrete above the freezing point and keep them completely free of frost, snow, and ice. Protection shall consist of insulating boards, blankets, or heated enclosures. Underside of slabs shall be heated during placement and protection period. Initial protection period shall be as indicated in tables 5.1 and 5.3 of ACI 306R. Maximum temperature drop of concrete surface after protection is removed shall follow table 5.5 of ACI 306R. Protect concrete work from physical damage or reduced strength, which could be caused by frost, freezing actions, or low temperatures, in compliance with ACI 306.1 and as herein specified.

5. Hot Weather Placement and Protection: When the mean daily temperature of the atmosphere is over 90°F during concreting, follow the procedures outlined in ACI 305R to protect the concrete.
 - a. All concrete, at the time it is actually deposited in the forms, shall have a temperature not lower than 50°F but never above 90°F.
 - b. Reduce concrete mixing time as required and specified herein to avoid quick stiffening of the concrete.
 - c. Cover reinforcement with water-soaked burlap to cool steel so its temperature will not exceed the ambient air temperature immediately before concrete placement.
 - d. Dry surfaces that are to receive concrete should be wet down with fog spray before commencing placement of concrete and the temperature of such surfaces should not exceed the temperature of the concrete being placed.
6. Concrete shall not be placed during rain, sleet or snow, nor shall rain, sleet or snow be permitted to fall upon uncured surfaces.

3.6 FINISHING OF SURFACES AND REPAIR OF SURFACE DEFECTS

A. General

1. Remove forms as soon as practicable. Refer to Section 03100 and Section BC 1906.2 of the 2014 NYC Building Code.
2. Repair surface defects, including tie holes and cracks, immediately after form removal. Patches shall be of quality to match the specified finish.
3. Remove oil, grease, compounds, and other contaminants from surfaces and areas to be repaired, those receiving coatings (ie. plaster, waterproofing, paint, and membranes of any kind).
4. Provide finishes specified below immediately after form removal.
5. Provide curing and protection.

B. Repair of Surface Defects

1. Remove all honeycombed and other defective concrete down to sound concrete. If chipping is necessary, the edges shall be perpendicular to the surface or slightly undercut. Undercut all cracks a minimum of 1" x 1". No feathered edges will be permitted. Dampen the area to be patched and an area at least 6" wide surrounding it to prevent absorption of water from the patching mortar. A bonding grout shall be prepared using a mix of approximately 1 part cement to 1 part fine sand passing a No. 30 mesh sieve, mixed to the consistency of thick cream, and then well brushed into the surface.
2. The patching mortar shall be made of the same materials and of approximately the same proportions as used for the concrete, except that the coarse aggregate shall be omitted and the mortar shall consist of not more than 1 part cement to 2¹/₂ parts sand by damp loose volume. Substitute white Portland cement for a part of the gray portland cement on exposed concrete in order to produce a color matching the color of the surrounding concrete, as determined by a trial patch. If the material color cannot be matched properly, the Contractor shall use a specialty repair mortar of the Engineer of Record's choice at the Engineer's discretion. The quantity of mixing water shall be no more than necessary for handling and placing. Mix the patching mortar in advance and allowed to stand with frequent manipulation with a trowel, without addition of water, until it has reached the stiffest consistency that will permit placing.
3. After surface water has evaporated from the area to be patched, brush the bond coat well into the surface. When the bond coat begins to lose the water sheen, apply the premixed patching mortar. The mortar shall be thoroughly consolidated into place and struck off so as to leave the patch slightly higher than the surrounding surface. To permit initial shrinkage, leave it undisturbed for at least 1 hr before final finishing. Keep the patched area damp for 7 days. Do not use metal tools for finishing a patch in a formed wall that will be exposed.

C. Repair of Tie Holes and Formed Surfaces

1. Remove ties, nails, and other form accessories below the concrete surface when the surface is exposed to view, the elements, or for surfaces to receive waterproofing or dampproofing. For surfaces not exposed to view or the above-mentioned conditions, remove metal to the surface. Refer to Section 03100.
2. Undercut surfaces of holes. After cleaning and thoroughly dampening the holes, fill them solid with the patching mortar. The mortar shall match the color of the existing concrete for concrete exposed to view as specified in paragraph B.2 above.
3. Remove and replace concrete having defective surfaces if defects cannot be repaired to satisfaction of Architect or Engineer. Surface defects, as such, include color and texture irregularities, cracks, spalls, air bubbles, honeycomb, rock pockets; fins and other projections on surface; and stains and other discoloration that cannot be removed by cleaning. Flush out form tie holes, fill with dry pack mortar, or precast cement cone plugs secured in place with bonding agent.
4. Repair concealed formed surfaces, where possible, that contain defects that affect the durability of concrete. If defects cannot be repaired, remove and replace concrete.

D. Repair of Unformed Surfaces

1. Test unformed surfaces, such as monolithic slabs, for smoothness and verify surface plane to tolerances specified for each surface and finish. Correct low and high areas as herein specified. Test unformed surfaces sloped to drain for trueness of slope, in addition to smoothness using a template having required slope.
2. Repair finished unformed surfaces that contain defects, which affect durability of concrete. Surface defects, as such, include crazing, cracks in excess of 0.01" wide or which penetrate to reinforcement, spalling, pop outs, honeycomb, rock pockets, and other objectionable conditions.
3. Correct high areas in unformed surfaces by grinding, after concrete has cured at least 14 days, but without exposing the reinforcing.
4. Correct low areas in unformed surfaces during or immediately after completion of surface finishing operations by cutting out low areas and replacing with fresh concrete. Finish repaired areas to blend into adjacent concrete. Use the specified underlayment or repair topping.
5. Repair defective areas, except random cracks and single holes not exceeding 1" diameter, by cutting out and replacing with fresh concrete. Remove defective areas to sound concrete with clean, square cuts and expose reinforcing steel with at least 3/4" clearance all around. Dampen concrete surfaces in contact with patching concrete and apply bonding compound. Mix patching concrete of same materials to provide concrete of same type or class as original concrete. Place, compact, and finish to blend with adjacent finished concrete. Cure in same manner as adjacent concrete.

6. Repair isolated random cracks and single holes not over 1" in diameter by dry pack method. Groove top of cracks and cut out holes to sound concrete and clean of dust, dirt, and loose particles. Dampen cleaned concrete surfaces and apply bonding compound. Mix dry pack, consisting of one part portland cement to 2 1/2 parts fine aggregate passing a No. 16 mesh sieve, using only enough water as required for handling and placing. Place dry pack after bonding compound has dried. Compact dry pack mixture in place and finish to match adjacent concrete. Keep patched area continuously moist for not less than 72 hours.

E. Formed Finishes

1. Rough Form Finish

- a. Provide for concrete not exposed to view and not covered with a material applied directly to the concrete, unless otherwise indicated under "Finishing" below.
- b. Formwork material given in Section 03100.
- c. Repair surface as indicated in B. and C. above.
- d. Chip or rub off fins exceeding 1/4" in height.

2. Smooth Form Finish

- a. Provide for concrete exposed to view, concrete receiving sheet membrane waterproofing or other covering material applied directly to the concrete, or as indicated under "Finishing" below. Areas exposed to view shall have a CS 3 or better finish as developed by the Cresset Chemical Company.
- b. Formwork material is given in Section 03100.
- c. Repair surfaces as indicated in B. and C. above.
- d. Chip or rub off fins completely and grind smooth.
- e. Provide smooth rubbed finish unless otherwise indicated below.

E. Unformed Finishes

At top of walls, horizontal offsets, and similar unformed surfaces occurring adjacent to formed surfaces, strike off smooth and finish with a texture matching adjacent formed surfaces. Continue final surface treatment of formed surfaces uniformly across adjacent unformed surfaces, unless otherwise indicated.

F. Finishing

1. Smooth Rubbed Finish

- a. Provide for smooth form finish except for those items listed in 2 below.
- b. Produce on newly hardened concrete no later than the day following form removal.
- c. Wet the surfaces and rub with a No. 16 carborundum brick or other equal abrasive to obtain a smooth, even surface of uniform appearance without applying any cement or other coating.
- d. Obtain the final finish by thoroughly rubbing with a No. 30 carborundum brick. The surface shall be wet for a period of 3 days. The Owner/Developer shall be the sole judge of whether the finish is proper.

2. Ceiling Surfaces, Beams and Columns

a. Non-painted Concrete

- 1) Locations: See Architectural Drawings or Schedule of Room Finishes on Drawings.
- 2) Work Required: Provide smooth form finish without rubbing.

b. Painted Concrete (CRP)

- 1) Locations: See Architectural Drawings or Schedule of Room Finishes on Drawings.
- 2) Work Required: In addition to smooth form finish, machine rub with carborundum or other approved abrasive to produce smooth finished surface. Cement wash not permitted.
- 3) Option: The Contractor has the option of substituting a white coat of plaster in lieu of providing rubbing for concrete ceilings.

- c. Acoustical Tile Ceiling: When the Drawings indicate that the tile is to be applied directly to the underside of concrete slabs, provide the non-painted concrete finish. However, exposed beam haunches and exposed columns shall be "CRP".
- d. Hung Ceiling: Where hung ceilings are indicated on Drawings or specified, provide a rough form finish.
- e. Columns: Exposed concrete surfaces of columns shall be non-painted concrete finish or "CRP" as determined by the required ceiling finish of the room in which columns are located.

G. Acceptance of Concrete Finish

If the finish produced is not acceptable to the Owner/Developer, the Contractor shall be responsible for all costs incurred to produce an acceptable finish by whatever means determined by the Owner/Developer.

3.7 SLABS

A. Placement

1. Deposit and consolidate concrete slabs in a continuous operation, within limits of construction joints (if required), until the placing of a panel or section is completed. Consolidate concrete during placing operations so that concrete is thoroughly worked around reinforcement and other embedded items and into corners. To obtain good surfaces and avoid cold joints, the size of finishing crews shall be planned with due regard for the effects of concrete temperature and atmospheric conditions on the rate of hardening of the concrete.
2. Mixing and placing shall be carefully coordinated with finishing. Do not place concrete on the subgrade or forms more rapidly than it can be spread, straightedged, and darbied or bull floated. Provide leveling, floating, troweling, etc. at the correct time interval after poring to prevent dusting and a non-durable surface as specified in ACI 302.1R. These operations must be performed before bleeding water has an opportunity to collect on the surface.

B. Leveling and Finishing

1. General

- a. Carefully provide slab depressions as required for the finishes indicated on the Drawings.
- b. Where floor drains or floor slopes are indicated, slope slabs uniformly to provide even fall for drainage.
- c. Follow detailed recommendations for finishing given in ACI 301, Section 5, and ACI 302.1R.
- d. Protect finishes from contamination from time of placing until time of acceptance, placement of topping, etc.
- e. Remove defects of sufficient magnitude to show through floor coverings or that do not meet tolerances by grinding.

2. Finishes

- a. Surfaces which receive bonded applied cementitious applications such as full-set vitreous ceramic tile, concrete fills and toppings, cementitious membrane waterproofing: Strike off and level to the proper elevation, plane surface to tolerances for floor flatness (F_F) of 15 and floor levelness (F_L) of 13. Slope surfaces uniformly to drains where required. After the topping has stiffened sufficiently to permit the operation, float the surface

to a uniform sandy texture. The surface shall then be broomed to a texture as approved by the Architect.

- b. Surfaces to receive floor coverings, such as resilient flooring, thin-set terrazzo and vitreous ceramic tile, carpeting, wood floors, thin film finish or surfaces that are exposed or painted finishes such as at auditorium floors and stairs, unless specified otherwise: After floating, begin first trowel finish operation using a power driven trowel. Begin final troweling when surface produces a ringing sound as trowel is moved over surface. Consolidate concrete surfaces by final hand troweling operation, free of trowel marks, uniform in texture and appearance, and with surface leveled to tolerances of FF 20 FL 17. Grind smooth surface defects, which would telegraph through applied floor covering system. Apply densifier/sealer to slabs exposed or painted, except for those specified below to have no finish. Apply two coats in accordance with the manufacturer's instructions at the proper time.
- c. Surfaces that are to receive trowel finish and other finishes as hereinafter specified, and slab surfaces which are to be covered with membrane or elastic waterproofing, membrane or elastic roofing, or sand bed terrazzo, and as otherwise indicated: After screeding, consolidating, and leveling concrete slabs, do not work surface until ready for floating. Begin floating when surface water has disappeared or when concrete has stiffened sufficiently to permit operation of power driven floats, or both. Consolidate surface with power driven floats, or by hand floating if area is small or inaccessible to power units. Check and level surface plane to tolerances of FF 18 FL 15. Cut down high spots and fill low spots. Uniformly slope surfaces to drains. Immediately after leveling, refloat surface to a uniform, smooth, granular texture.
- d. Surfaces with no finishes: Areaways, pipe and duct, and crawl spaces; Level and wood float surface level or toward drains if required.
- e. Pavements: Finish surface to a true smooth plane and texture with a toothed roller or float with a wood float. Score concrete pavement in squares of approximately 5'-0" and/or as shown on Drawings. Each rectangular slab shall have all edges neatly rounded with proper tools and be bounded on all sides by a troweled border about 1" in width.
- f. Concrete stair treads, platforms, ramps, sloped walks, and elsewhere as indicated: After completion of float finishing, and before starting trowel finish, uniformly spread 25 lbs. of dampened non slip aggregate per 100 sq. ft. of surface. Tamp aggregate flush with surface using a steel trowel, but do not force below surface. After broadcasting and tamping, apply trowel finishing as herein specified. After curing, lightly work with a steel wire brush, or an abrasive stone, and water to expose non slip aggregate. Immediately following first floating operation, uniformly distribute approximately 2/3 of required weight of dry shake material over concrete surface, and embed by means of power floating. Follow floating operation with second shake application, uniformly distributing remainder of dry shake material at right angles to first application, and embed by power

floating. After completion of broadcasting and floating, apply trowel finish as herein specified. Cure slab surface with curing compound recommended by dry shake hardener manufacturer. Apply curing compound immediately after final finishing.

- g. Non-oxidizing Metallic Floor Hardener: All slabs, in the loading dock area, or other areas noted on the drawings, shall receive an application of the non-oxidizing, metallic floor hardener applied at the rate of 1.5 lbs/ft². Immediately following the first floating operation, uniformly distribute approximately 2/3 of the required weight of the non-oxidizing metallic floor hardener over the concrete surface, by mechanical spreader, and embed by means of power floating. The hardener shall be floated in and the second application made. The surface shall be floated again to properly bond the hardener to the base concrete slab. The surface shall then be troweled, at least twice, to a smooth dense finish. After completion of broadcasting and floating, apply trowel finish as herein specified. Cure slab surface with curing compound recommended by hardener manufacturer. Apply curing compound immediately after final finishing.
- h. Liquid Densifier/Sealer: All interior slabs subject to hard-wheeled vehicular traffic, and so noted on the drawings, shall be treated with the specified liquid densifier/sealer. Spray, squeegee or roll on liquid densifier to clean, dry concrete surface. The liquid should be scrubbed into the surface with a mechanical scrubber. Keep the surface wet with the densifier during the application process. When the product thickens, but not more than 60 minutes after initial application, the surface shall then be squeegeed or vacuumed to remove all excess liquid.

C. Slabs on Grade

1. General

- a. Aggregate base and crushed stone base material and preparation is part of Work of Section 02200.
- b. Where pavements to remain are damaged or destroyed as a result of the Work, patch, repair, or replace as required. Color to match existing.
- c. Subgrade and/or aggregate base/crushed stone base shall be free of frost before concrete placing begins.
- d. Control Joints:
 - 1) Primary Method: Soff-Cut System method, by Soff-Cut International, Corona, CA (800)776-3328. Finisher must have documented successful experience in the use of this method prior to this project. Install cuts within 2 hours after final finish at each saw cut location. Use 1/8 inch thick blade, cutting 1¹/₄ inch into slab.

- 2) Optional Method (Where Soff-Cut System Method Equipment is Not Available): Properly time cutting with the set of the concrete. Saw-cut control joints within 12 hours after finishing. Start cutting as soon as the concrete has hardened sufficiently to prevent aggregates being dislodged by the saw. Complete cutting before shrinkage stresses become sufficient to produce cracking. Use 1/4" thick blade, cutting 1/4 slab depth.
2. Slabs where vapor barrier required
 - a. Provide vapor barrier for all interior slabs on grade except for pipe and duct and crawl spaces.
 - b. Install vapor barrier in accordance with manufacturer's instructions and ASTM E1643. Just prior to concrete placement, check vapor barrier for punctures and repair as specified below.
 - 1) Unroll vapor barrier with the longest dimension parallel to the direction of pour.
 - 2) Lap barrier over footings and seal to foundation walls.
 - 3) Overlap joints 6" and seal with pressure sensitive tape.
 - 4) Seal all penetrations with pipe boots.
 - 5) No penetration of the barrier is allowed except for reinforcing steel and permanent utilities.
 - 6) Repair damaged areas by cutting patches of vapor barrier, overlapping damaged areas 6", and taping all four sides with pressure sensitive tape.
 - c. Pour slab to required thickness after installation of reinforcement.
 - d. Conduit, drains, piping and other items shall be placed prior to installation of the vapor barrier.
 3. Slabs where vapor retarder required
 - a. Provide vapor retarder for all slabs on grade of pipe and duct and crawl spaces.
 - b. Place vapor retarded over compacted base, providing 6" minimum lap at ends. Install vapor retarder in accordance with manufacturer's instructions. Repair damaged areas by cutting patches of vapor barrier, overlapping damaged areas 6.
 - c. Pour slab to required thickness after installation of reinforcement.

4. Slabs where no vapor barrier required
 - a. Dampen subgrade or aggregate/crushed stone base immediately prior to placement of concrete.
 - b. Pour slab to required thickness after installation of reinforcement.
5. Pavements, Areaways
 - a. Provide 4" thick concrete slab unless otherwise indicated.
 - b. Provide 6x6-W2.9xW2.9 WWF placed 1 $\frac{1}{2}$ " from top surface.
 - c. When a flagpole is indicated on the ground, form a paved circle around the flagpole as indicated. The pavement in this area shall have a slope of 2" away from the pole.
6. Driveways
 - a. Provide 7" thick concrete slab.
 - b. Provide 4x4-W4xW4 welded wire reinforcing placed 2" from top surface.
7. Slab for Handball Court:
 - a. Provide 5" thick concrete slab.
 - b. Provide 4x4-W4xW4 welded wire reinforcing placed 1 $\frac{1}{2}$ " from top surface.
 - c. Expansion joints are to be placed outside the playing surfaces.
8. Expansion joints
 - a. Provide expansion joints for all exterior concrete pavements, driveways, etc. specified under this Section or as shown on Drawings. Expansion joints shall occur at intervals not to exceed 20' in each direction or as indicated on Drawings.
 - b. Provide continuous expansion joints at the following locations: Driveways and other concrete pavements abutting area walls, buildings, retaining or any other walls, check pieces, steps, curbs. Also provide at the perimeter of interior slabs on grade (except for framed slabs) and as indicated on contract drawings.
 - c. Expansion joint shall be 1/2" wide, full depth, and flush except where sealer is to be provided at exterior pavements, driveways, and where indicated on Drawings. In this case joint shall be full depth minus 1/4" to allow for the poured joint sealer.

D. Slab on Metal Deck

1. Provide, at no extra cost to the owner, extra concrete as required to make up for any deflections in the metal deck and steel beams in order to provide a level surface using a laser.
2. Concrete for slabs on metal deck supported by steel members shall be placed and finished in a manner that produces uniformly thick slabs above the steel framing members.

E. Structural Lightweight Concrete Fill

1. Structural lightweight concrete fill is required at the following location:
 - a. As a gradient fill on the roof slab to obtain the required slope.
 - b. As a gradient fill to receive setting beds where structural slab is more than 2" below finished floor level.
 - c. Other areas as indicated on Drawings.
2. Prepare concrete surface to receive fill by cleaning laitance, grease, oil, dust, etc. by mechanical or other acceptable means.
3. Immediately prior to placement of fill, dampen surface (without leaving standing water) and scrub in bonding grout composed of a mix of approximately 1 part cement to 1 part fine sand passing a No. 30 mesh sieve, mixed to the consistency of thick cream or the bonding agent. Do not allow bonding grout to set or dry before fill is placed.
4. Provide finish as specified in paragraph B of this Article.

3.8 MISCELLANEOUS CONCRETE WORK

- A. Provide trap-pits, curbs, walls, retaining walls, ramps, athletic field work and other miscellaneous concrete items.
- B. Provide monolithic finish to interior curbs by stripping forms while concrete is still green and steel troweling surfaces to a hard, dense finish with corners, intersection, and terminations slightly rounded. If the curb is part of a beam, the form shall be removed as specified in the section for beams.
- C. Provide concrete fill for steel pan stair treads and landings and associated items. Cast in safety inserts and accessories as shown on drawings. Screed, tamp, and finish concrete surfaces as scheduled.
- D. Provide motor, blower, and other mechanical bases as shown on drawings. Set anchor bolts complying with equipment shop drawings or templates of manufacturer furnishing machines and equipment. Bases poured on concrete slabs shall be same type of concrete as slab, unless specifically noted otherwise on the Drawings. Foundations shall be normal

weight, 4 ksi concrete, unless noted otherwise. Trowel concrete to a smooth, dense finish. Coordinate with the work of Division 15 and 16.

- E. Provide concrete topping as shown on drawings. Clean surface of underlying slab of all oil, dirt, laitance and any other material, which could impair bond. Moisten existing concrete thoroughly prior to placing topping. Use structural macro fibers at 4 lbs. per cubic yard in 4000 psi topping, with a maximum w/cm of 0.50, unless otherwise indicated on the plans. Approved curing procedure must begin immediately after final finishing. The joint pattern must be approved by the engineer.

3.9 PATCHING AND BONDING TO EXISTING CONCRETE

- A. Provide bonding agent whenever new concrete is to be poured against existing concrete, whenever the time between concrete pours is longer than that allowed for proper bond, and wherever bonding agent is indicated on the Drawings to be applied.
- B. Remove loose concrete from surface to be bonded with new concrete and clean. Remove rust from reinforcement and structural steel by power chipping and power driven brushes.
- C. Apply bonding agent in accordance with manufacturer's specifications. Pour concrete as soon as bonding agent has cured and within 20 hours after application. If the 20-hour period has elapsed, then the bonding agent must be reapplied.

3.10 CURING AND PROTECTION

A. General

1. Begin curing concrete as soon as free water has disappeared from concrete surface after placement and finishing. Protect all freshly deposited concrete from rain, premature drying and excessively hot or cold temperatures and maintain it with minimal moisture loss at a relatively constant temperature for the period of time necessary for the hydration of the cement and proper hardening of the concrete. Detailed procedures are given in ACI 308 and Section BC 1905.11 of the 2014 NYC Building Code.
2. Cure floor surfaces in accordance with ACI 308.
3. Do not apply curing compounds to surfaces receiving waterproofing, adhesives, membranes or additional concrete unless approved by adhesive or material manufacturer or compound is removed in an approved manner. As an alternate, provide wet curing.
4. All exposed interior slabs, not receiving a liquid densifier, and troweled slabs receiving mastic applied adhesives or "shake-on" hardeners shall be cured with the specified curing and sealing compound. Exterior slabs, sidewalks, curbs, and architectural concrete, not receiving a penetrating sealer, shall be cured with the specified curing and sealing compound. Maximum coverage shall be 400 ft²/gallon on steel troweled surfaces and 300 ft²/gallon on floated or broomed surfaces for curing/sealing compound.

B. Procedure

1. Concrete surfaces not in contact with forms:
 - a. Ponding or continuous non-manual sprinkling.
 - b. Absorptive mat or fabric, sand, or other covering kept continuously wet. Place to provide coverage of concrete surfaces and edges, with 4" lap over adjacent covers.
 - c. Cover concrete surfaces with moisture retaining cover for curing concrete, placed in widest practicable width with sides and ends lapped at least 3" and sealed by waterproof tape or adhesive. Immediately repair any holes or tears during curing period using cover material and waterproof tape.
 - d. Curing compounds conforming to ASTM C1315 or where bond and adhesion of mortar, adhesive or other finish material will be adversely affected use strippable curing compound conforming to ASTM C309.
 - e. Treat slabs, ramps, curbs and columns and walls two feet up from top of slabs with penetrating sealer in areas that will be exposed to deicing salts in service. Follow manufacturer's instructions for dosage and procedures.
 2. Concrete surfaces in contact with forms:
 - a. Minimize moisture loss from forms exposed to heating by the sun by keeping forms wet until they are removed.
 - b. After form removal, cure with one of the methods listed in 1 above.
 3. Being final curing immediately following initial curing and continue curing until a total of 7 days has elapsed during which the temperature of the air in contact with concrete has remained above 50°F, in accordance with ACI 301 procedures. Prevent rapid drying during and at the end of the curing period.
 4. Remove all curing compounds with cleaners recommended by curing compound manufacturer.
- C. Cold Weather Curing
1. Concrete must be protected from water loss. This shall be accomplished by the application as soon as possible without harm to the concrete surfaces of either (a) exhaust steam, or vapor-resistant paper or polyethylene film, or (b) curing compounds. In all other respects, curing shall conform to applicable provisions of this Section. Concrete temperature shall be maintained between 50°F and 70°F. Comply with ACI 306.1
 2. Protection of concrete in cold weather shall continue long enough to ensure the strength required, but not less than 72 hours. The temperatures shall be kept sufficiently above freezing. Protection from freezing for the first 24 hours does not ensure the strength required.

3. The surface temperature of the concrete shall be monitored especially at corners and edges of concrete. Use thermometers or any other equipment approved for this type of work. The Contractor shall provide all the equipment necessary to protect and monitor the curing of concrete. After the concrete has cured and the above requirements are no longer necessary, the temperature shall be decreased slowly and gradually as required by ACI 306.1. Under no circumstances are sudden changes of temperature in the concrete allowed. Heating units shall be vented. The concrete shall be protected from drying when heated locally by the heating locally by the heating equipment.
4. The heating enclosures, if used, must be strong, windproof and weatherproof.
5. Concrete shall not be exposed to carbon dioxide (CO₂) gas or any other pollution resulting from the use of heating equipment. The temperature shall not exceed those shown in ACI 306.1.
6. The use of urethane foams as insulation shall be avoided if possible or done with caution, as it generates highly noxious fumes when subject to fire.

D. Hot Weather Curing

1. During the period June 1 to October 1 or when hot weather conditions require it, maintain continuous water curing for a minimum period of twenty-four hours. Provide for windbreaks, shading, and other necessary provisions.
2. After 24 hours, curing shall be by one of the methods specified under B above. In all other respects, curing shall conform to applicable provisions of this Specification. Upon termination of the specified moist curing, every effort should be made to reduce the rate of drying by avoiding air circulation.
3. Comply with ACI 305R.

E. Protection from mechanical injury: Protect concrete from mechanical disturbances during curing period as described under "Protection and Cleaning".

F. Penetrating Sealer: Apply at a rate of 125 square feet per gallon. Sweep and power wash concrete surface before application. Do not apply until time period specified in manufacturer's instructions.

3.11 FIELD QUALITY CONTROL

A. Tests

Method of tests shall in all cases comply in detail with the latest applicable ACI and ASTM requirements as well as the NYC Building Code and be performed by an ACI Concrete Field Testing Technician Grade 1 or equivalent. Tests to be performed by the Owner/Developer's Testing Laboratory during construction are as follows:

1. Compliance of materials to Specifications tested from production samples.

2. Testing Agency may inspect and test materials and work at the source before shipment as well as at the site before, during or at any time after installation. Deficient or incomplete work or materials shall be corrected or replaced, as directed by the Engineer, without additional costs or delays to the Owner.
3. Determination of the slump of the concrete for each sample taken and whenever consistency of the concrete appears to vary using ASTM C143. When a high-range, water reducing admixture is being used, slump tests shall be made before and after the admixture is added. The Special Inspector will reject any concrete that does not meet the slump requirements.
4. Determination of water content of freshly mixed normal weight concrete utilizing the procedure of AASHTO T318. Concrete that does not meet the maximum water to cement ratio or the proportions given in the approved design mix will be immediately rejected regardless of slump.
5. Strength tests on the specimens in accordance with ASTM C39:
 - a. The frequency of conducting strength tests of concrete shall be in accordance with Section BC 1905.6.2 of the 2014 NYC Building Code, with additional cylinders taken for an additional strength test and one cylinder for a 7-day break. Strength tests shall be performed for each 50 cubic yards, or portions thereof, of concrete placed in any one day's concreting. Specimens will be stored at the site in the insulated curing box provided by the Contractor. Each group of specimens is considered one strength test. One cylinder will be broken at 7 days for information.
 - 1) Portland cement concrete: A strength test shall be performed at 28 days for acceptance. The remaining cylinders for the additional strength test will be tested only if the 28-day breaks are low or durability of the concrete is in question.
 - 2) Portland cement concrete with 40% alternate cementitious material: A strength test will be performed at 28 days to determine if the strength has been made and/or if the strengths are sufficient to continue work, even if not at the required design compressive strength. Depending on temperature, concrete strength can be attained at 28 days even though the strength is considered a 56-day strength. If the first cylinder tested indicates the strength has not been met, the remaining cylinders of the test will be broken at a later date. One set of strength test will be done at 56 days.
 - b. If one specimen in a test manifests evidence of improper sampling, molding, or testing, it shall be discarded and the average strength of the remaining cylinders shall be considered the test result. Should all specimens in a test show any of the above defects, the entire test shall be discarded.
 - c. When intermediate conveyance is used to place the concrete, one additional set of cylinders shall be taken for each 150 cubic yards or

fraction thereof for each type of concrete placed in any one day's concreting. These test cylinders shall be separate and distinct from those made in the mixer and shall be made in the same batch and cured and tested in the same manner as samples taken from the mixer.

- d. Test reports shall include name of Testing Agency and project, date of concrete placement, type of concrete, exact location of concrete batch in structure and results of 7 and 28 day tests and shall be specially marked to clearly identify any and all results falling below specified strength.
6. Determination of air content and unit weight of normal weight concrete sample for each strength test in accordance with ASTM C173 or C231 and ASTM C138. Test every time compressive strength cylinders are taken. The results of such tests shall be included in the Testing Agency's written reports.
7. Determination of air content and unit weight of lightweight concrete sample for each strength test in accordance with ASTM C173 or C231 and ASTM C567. Test every time compressive strength cylinders are taken. The results of such tests shall be included in the Testing Agency's written reports.
8. Determination of temperature of concrete sample for each strength test. When the air temperature is below 40 degrees F or above 80 degrees F, test at discharge from every truck. The results of such tests shall be included in the written reports.
9. Tests for water soluble ion chloride content shall be made in accordance with ASTM C114 for concrete that has a maximum chloride ion content specified in this Specification. Test every time compressive strength cylinders are taken. The results of such tests shall be included in the Testing Agency's written reports.
10. For concrete with a design strength of more than 4 ksi, cement samples shall be taken directly from the hopper at the batching plant and tested in accordance with ASTM C109. Samples shall be taken randomly, in quantities directed by the Engineer, throughout the project at each shipments of bulk cement and at additional times as directed by the Engineer.

B. Inspections

1. Refer to "Source Quality Control" for responsibility and procedure.
2. The Contractor shall cooperate in the making of all tests by the Laboratory Technician by:
 - a. Providing a well-constructed shanty, to be approved by the Owner/Developer, located adjoining the Owner/Developer's inspector's office. This shanty shall have an area of not less than 50 sq ft, be well lighted, and provided with a table for mixing concrete, shelves for storage of the Laboratory's equipment, molds, etc., one chair, hinged door with suitable lock and complying with all requirements of ACI and ASTM.
 - b. Providing an insulated curing box of sufficient size and strength to contain all specimens made in any four consecutive working days. The Contractor

- shall furnish an outlet to provide the necessary temperature in the storage box, pending delivery to the Laboratory of the test cylinders.
- c. Providing a buggy for transporting the concrete taken from the mixer (and/or point of placement) to the shanty for testing and the preparation of specimens.
 - d. Protecting the property of the Laboratory to be stored in the shanty and keeping test specimens free from vibration and other disturbances.
 - e. Providing a microwave of the size specified in AASHTO T318 and a portable generator.
 - f. Provide a complete set of all current Construction Documents (including a current sketch log) and Specifications.
 - g. Provide a current set of approved Shop Drawings.
 - d. Provide concrete placement schedules.
3. Inspections shall include but not be limited to:
- a. Control of concrete at the batching plant, including tests of materials for moisture, gradation and cleanliness; and determination and recording of all mixture quantities and water/cement ratios. Verify that quantities and materials conform to the accepted trial mixes, adjusted for moisture content of aggregates.
 - b. Verification of sizes and thickness of structural members, such as slab and wall thickness, beam and column dimensions, etc. Layout, alignment, plumbness, etc. are the sole responsibility of the Contractor.
 - c. Inspection of all concrete placing, finishing, and curing operations. Verify that all concrete forms and reinforcing are clean and free of dirt and debris at time of pour and that concrete is properly deposited, consolidated, finished and cured.
 - d. Inspection of all reinforcing; verifying size, number, spacing, location, splices, support, wiring, etc. of all reinforcing bars, mesh, and stud rails. The location and installation details of reinforcing and prestressing steel shall be inspected for compliance with the approved Construction Documents and ACI 318. Inspections shall be made only with shop drawings bearing the Engineer's stamp and marked "No Exception Taken" or "Make Corrections Noted" only. Refer to Reinforcing Specification.
 - e. Placement and location of embedded items such as sleeves, inserts, railings, etc. is the responsibility of the Contractor and Construction Manager.

C. Evaluation and Acceptance of Concrete

1. Strength tests on structural concrete will be evaluated according to Section BC 1905.6.3.3 of the 2014 NYC Building Code.
2. When the average strength of the test cylinders, as defined in Section BC 1905.6.3.3 falls consistently below the specified strength (f'_c), the Engineer shall have the right to order the Contractor to change the proportions or the water content of the concrete to secure the required strength for the remaining portion of the structure, all at the Contractor's expense. It is the Contractor's complete responsibility to modify the concrete mix design, material controls, and/or concrete operations where necessary to obtain the compressive strength required by the design and Specification.
3. When the average strength of test cylinders for any portion of the structure is less than that required by the design or Specification, or where there is other evidence that the quality of the concrete is below Specification requirements, the adequacy of the concrete will be checked according to the requirements of Section BC 1905.6 either by structural analysis or by core or load tests or by any combination of these procedures. The Engineer of Record will determine which procedures to use:
 - a. Structural Analysis Computations (Section BC 1905.6.5.5), which will be performed by the Engineer of Record.
 - b. Core Tests (Section BC 1905.6.5.2) - Performed in accordance with ASTM C42.
 - c. Load Tests (AC1318 Paragraph 20.3 or Section BC 1713 of the Building Code).
4. Exterior concrete exposed to the elements with low strength test results or other evidence of poor durability will be rejected.
5. Low Strength Tests of Concrete or evidence of poor durability - Results
 - a. Pay for additional costs of labor and materials required at the job for all damages resulting from load tests and the taking of cores. Remove and replace concrete work that is not of adequate strength or durability and cannot be made to work by remedial methods acceptable to the Owner/Developer at own cost. The Contractor shall be held responsible for all delays and damages to the work of other Divisions that occur as a result of non-conformance.
 - b. Pay for all expenses borne by the Owner/Developer resulting from low strength test procedures or evidence of poor durability (such as high slump) specified above.

D. Contractor's Surveys

Provide surveys of finished concrete elevations for all building slabs. Provide elevations taken on a 15-foot grid pattern. Indicate discrepancies between contract elevation and actual. Interpolate sloped areas such as roof slabs. Do not proceed with finish work until slabs are repaired.

3.12 PROTECTION AND CLEANING

A. General

During the curing period, and thereafter as conditions may require, protect the concrete from damaging mechanical disturbances, particularly excessive load stresses, heavy shock, and excess vibration. Protect all finished concrete surfaces from damage caused by construction equipment, materials or methods, and by rain or running water. Self-supporting structures shall not be loaded in such a way as to overstress the concrete.

B. Floors

Floors that have received their final finish shall be closed to all traffic for at least 48 hours following the completion of troweling. Avoid damage to the floor and repair, clean, and prep floor for finishes.

3.13 ACCEPTANCE OF CONCRETE WORK

A. General

1. Completed concrete work that meets all applicable requirements will be accepted without qualification.
2. Completed concrete work which fails to meet one or more requirements but which has been repaired to bring it into compliance will be accepted without qualification.
3. Completed concrete work which fails to meet one or more requirements and which cannot be brought into compliance may be accepted or rejected as provided in these Specifications or in the Contract Documents. In this event, modifications may be required to assure that remaining work complies with the requirements.
4. Concrete work judged inadequate by structural analysis, core test, results of load test or deemed unacceptable due to appearance or durability concerns shall be repaired, reinforced with additional construction if so directed by the Engineer of Record, or be replaced if so directed by the Engineer at the Contractor's expense.
5. Pay all costs incurred by the Owner/Developer in providing additional testing and/or analysis required by this Section.
6. The Owner/Developer will pay all costs of additional testing and analysis made at its own request that is not required by this Section or that shows concrete is in compliance with the Contract Documents.

B. Dimensional Tolerances and Measurements

1. Lay out each part of the work in strict accordance with the Contract Documents. Precise measurements and layout are the sole responsibility of the Contractor.
2. Obtain all field measurements required for proper detailing, fabrication and installation of the work. Field verify all dimensions and locations of existing conditions shown on the Contract Documents. Where discrepancies exist, notify Engineer in writing, and by sketch when applicable, of discrepancies and proposed solutions to correct discrepancies.
3. For Formed Surfaces unless otherwise specified or noted on the Drawings, conform to the requirements given below or as given in ACI 117, whichever is more stringent. All tolerances shall apply to the full height of the building. Variations from grade shall be measured prior to removal of formwork.
 - a. Variation from plumb:
 - i. In the lines and surfaces of columns, piers, walls, corners and the like:
 - a. In any 10 ft. of length 1/4 in.
 - b. Maximum for the entire height 1 in.
 - ii. For exposed corner columns, control joint grooves, and other conspicuous lines:
 - a. In any 20 ft. of length 1/4 in.
 - b. Maximum for the entire height 1/2 in.
 - b. Alignment:
 - i. At slab and/or beam, alignment of columns or walls above and below:
 - a. Maximum offset 1/4 in.
 - c. Variation from level or specified grades and elevations:
 - i. In slab, beam and girder soffits and the like:
 - a. In any 10 ft. length 1/4 in.
 - b. In any bay or in any 20 ft. length 3/8 in.
 - c. Maximum for the entire length 3/4 in.
 - ii. In exposed lintels, sills, parapets, horizontal grooves, and other conspicuous lines:
 - a. In any bay or in 20 ft. length 1/4 in.
 - b. Maximum for the entire length 1/2 in.

- d. Variation of building lines from theoretical positions in plan and related positions of columns, walls, piers and the like:
- i) In any bay 1/4 in.
 - ii) In any 20 ft. length 1/4 in.
 - iii) Maximum for the entire length 1/2 in.
- e. Sleeves, wall openings and floor openings:
- i) Variation in size 1/4 in.
 - ii) Variation in location 1/2 in.
- f. Variation in cross sectional dimensions of columns and beams and in thickness of slabs and walls:
- i) Minus 1/4 in.
 - ii) Plus 1/2 in.
- g. Variation in the location of anchors and inserts shown in accepted shop drawings, unless more stringent tolerances are required for work of other Sections:
- i) Vertically 3/8 in.
 - ii) Horizontally 1/4 in.
- h. Faces of formed slab edges, turned down spandrels, and parapets shall not deviate from theoretical position or alignment by more than the distance in consideration divided by 500 or by 1/2 inch, whichever is less.
- i. Footings:
- i) Variations in dimensions in plan:
 - a. Minus 1/2 in.
 - b. Plus 2 in.
 - ii) Misplacement or eccentricity:
 - a. 2 percent of the footing width in direction of misplacement but not more than 2 in.
 - iii) Thickness:
 - a. Decrease in specified thickness 5 percent
 - b. Increase in specified thickness No limit
 - iv) Elevation at steel bearing plates:
 - a. Plus 1/4 in.
 - b. Minus 1/4 in.
- j. Variation in stair dimensions:

- | | | |
|----|------------------------|----------|
| a. | In a flight of stairs: | |
| a. | Rise | 1/8 in. |
| b. | Run | 1/4 in. |
| b. | In consecutive steps: | |
| a. | Riser | 1/16 in. |
| b. | Tread | 1/8 in. |
-
4. Formed surfaces resulting in concrete outlines smaller than permitted by the tolerances of this Section or Section 03100 shall be considered potentially deficient in strength and subject to the provisions of paragraph D below.
 5. Formed surfaces resulting in concrete outlines larger than permitted by the tolerances of this Section or Section 03100 may be rejected and the excess material subject to removal. If removal of the excess material is permitted, it shall be accomplished in such a manner as to maintain the strength of the section and to meet all other applicable requirements of function and appearance.
 6. Concrete members cast in the wrong location may be rejected if the strength, appearance, or function of the structure is adversely affected or if misplaced items interfere with other construction.
 7. Inaccurately formed concrete surfaces exceeding the tolerances of this Section or Section 03100 and which are exposed to view may be rejected and shall be repaired or removed and replaced if required.
 8. Slab tolerance from theoretical elevation is 1/2" plus or minus in accordance with ACI 117. Finished slabs exceeding the tolerances, including specified levelness tolerances, may be repaired provided that the strength or appearance is not adversely affected. High spots may be removed with a terrazzo grinder, low spots filled with a structural repair mortars, or other remedial measures performed as permitted. Provide self-leveling cement based materials for large expanses of deficient areas. All materials shall be approved by the Engineer of record and installed by the Contractor at its cost.
 9. For tolerances not specifically indicated in the Contract Document, follow requirements of ACI 117.

C. Appearance

1. Concrete exposed to view with defects that adversely affect the appearance of the specified finish may be repaired only by approved methods.
2. Concrete not exposed to view is not subject to rejection for defective appearance.

D. Strength of Structure

1. The strength of the structure in place will be considered potentially deficient if it fails to comply with any requirements that control the strength of the structure, including but not necessarily limited to the following conditions:
 - a. Low concrete strength as described under "Field Quality Control".
 - b. Reinforcing steel size, quantity, strength, position, or arrangement at variance with the requirements of Section 03200 or the Contract Documents.
 - c. Concrete that differs from the required dimensions or location in such a manner as to reduce the strength.
 - d. Curing less than that specified.
 - e. Inadequate protection of concrete from extremes of temperature during early stages of hardening and strength development.
 - f. Mechanical injury as defined under "Protection and Cleaning", construction fires, accidents, or premature removal of formwork likely to result in deficient strength.
2. Structural analysis and/or additional testing may be required when the strength of the structure is considered potentially deficient.
3. Core tests may be required when the strength of the concrete in place is considered potentially deficient.
3. If core tests are inconclusive or impractical to obtain or if structural analysis does not confirm the safety of the structure, load tests may be required and their results evaluated in accordance with Chapter 20 of ACI 318.

3.14 CONCRETE STRUCTURAL REPAIRS

- A. Perform structural repairs only where accepted, by Architect, Owner and Engineer, in detailed procedure submitted by Contractor in writing. All other defective areas shall be removed and replaced.
 1. Conform to Article 1.7 of ACI 301, "Specification for Structural Concrete for Buildings" and to instructions of Engineer.

END OF SECTION 033000

LIST OF SUBMITTALS

SUBMITTAL	DATE SUBMITTED	DATE APPROVED
-----------	----------------	---------------

Product Data:

1. Admixtures
2. Curing compounds
3. Hardener
4. Densifier/Sealer
5. Bonding agent
6. Vapor barrier
7. Vapor retarder
8. Waterstop
9. Beam clip
10. Joint Fillers

Samples:

1. Vapor barrier
2. Vapor retarder
3. Waterstop
4. Beam clip

Design Data/Test Report:

1. Foundation concrete mix
2. Superstructure concrete mix

Certificates:

1. TR3
2. Admixture chloride content
3. Concrete laboratories certificate
4. Concrete producer is NYSDOT Approved
5. Concrete producer's Batch Ticket to field rep.

Manufacturer's Instructions:

1. Waterstop

Qualifications

1. Concrete Installer
2. Concrete producer

Survey:

1. Slab survey

Mock Up:

1. Smooth Form Finish
2. Architectural Concrete Finish
3. Exterior pavement texture

Sustainable Submittals:

1. Contractor's Sustainable
Materials Form (see Section S01352).
2. Mfr's printed literature
or statement on recycled and
regionally extracted and
manufactured material content.

CONCRETE MIX DESIGN SUBMITTAL FORM

Project:

City:

General Contractor:

Concrete Contractor:

Contact Name:

Address:

Phone Number:

Main Plant Location:

Miles from Project Site:

Date:

Design Characteristics

Use (describe):

Strength: psi at days

Density: pcf

Air: % Water/cementitious ratio:

Design Mix Information – check one

Based on Standard Deviation Analysis of Trial Mixes or Field Experience.

No. of test cylinders: Avg. Strength: psi

Standard deviation: f'_{cr} : psi

$$f'_{cr} = f'_{c} + 1.34s \text{ or } f'_{cr} = f'_{c} + 2.33s - 500$$

Refer to ACI 318 Sec. 5.3.1 for standard deviation factor if less than 30 tests

Based on Trial Mix Test Data.

f'_{cr} : psi

$$f'_{cr} = f'_{c} + 1200 \text{ psi, for up to 5000 psi}$$

$$f'_{cr} = 1.10 f'_{c} + 700 \text{ psi, for greater than 5000 psi}$$

SECTION 051200 – STRUCTURAL STEEL

PART 1 - GENERAL

1.1 RELATED DOCUMENTS

- A. Drawings, conditions of the Contract (including General, Supplementary, and Special Conditions), Division 01 Specification Sections and all other Contract Documents apply to work of this Section.

1.2 WORK INCLUDED

- A. Extent of structural steel work is shown on the Drawings, including schedules, notes and details to show size and location of members, typical connections, and type of steel required.
- B. Provide all labor, materials, equipment, services and perform all operations required for complete furnishing, fabrication, and erection of all structural steel as indicated on the Drawings, specified in this Section, and required by job conditions.
- C. The work shall include but not be limited to the following:
 - 1. Columns, posts, struts and hangers.
 - 2. Base plates and bearing plates.
 - 3. Anchor bolts and plates to be embedded in concrete.
 - 4. Templates for items to be embedded in or attached to concrete.
 - 5. Structural steel support angles, channels, etc. for metal deck.
 - 6. Shop painting, lacquering and galvanizing and field touch-up.
 - 7. Bracing, guying, surveying and plumbing of erected steel.
 - 8. Shoring and temporary bracing.
 - 9. Connections.
 - 10. Shop applied stud shear connectors.
 - 11. Concrete reinforcing bar coupling devices which are to be welded to structural steel.
 - 12. Drilled-in anchors into concrete or masonry to fasten structural steel.
 - 13. Deformed anchor bars stud welded to structural steel.
 - 14. Erection drawings, shop drawings and samples.
 - 15. Protection of work of this Section.
 - 16. Protection of other work from activities under this Section.
 - 17. Submittals.
 - 18. Provisions for other work.
 - 19. All other work shown in the Drawings, specified in this Section or required to make the structural steel work complete.

1.3 RELATED WORK SPECIFIED ELSEWHERE

- A. Submittals – Division 1 Sections.
- B. Cast-In-Place Concrete - Section 03300.

1.4 CODES AND STANDARDS

- A. Conform to the requirements of the New York City Building Code.

- B. The following codes, specifications and standards shall apply to the work. Where conflict among codes, standards, and specifications exist, the one having the most stringent requirements shall govern.
1. Specification for Structural Steel Buildings - AISC 360-10 by the American Institute of Steel Construction ("AISC Specification").
 2. Code of Standard Practice for Steel Buildings and Bridges, AISC 303-05 by the American Institute of Steel Construction ("AISC Code"). Sections 6 and 7 apply to the work; the remainder is specifically excluded. Chapter 10 applies to members designated in the Contract Documents as Architecturally Exposed Structural Steel ("AESS").
 3. Specification for Structural Joints Using High-Strength Bolts, August 1, 2014, by the Research Council on Structural Connections of the Engineering Foundation ("RCSC Specifications").
 4. Standard Symbols for Welding, Brazing and Nondestructive Examination, AWS A2.4, by the American Welding Society ("AWS A2.4").
 5. Structural Welding Code - Steel, AWS D1.1, by the American Welding Society ("AWS D1.1").
 6. Structural Welding Code - Reinforcing Steel, AWS D1.4, by the American Welding Society ("AWS D1.4").
 7. American Society for Testing and Materials ("ASTM") specifications cited shall be the latest edition listed in the Index of the Annual Book of ASTM Standards.
 8. Detailing for Steel Construction, 2009, by the American Institute of Steel Construction.
 9. SSPC Steel Structures Painting Manual, by the Steel Structures Painting Council ("SSPC").
- C. Work of this Section shall conform to all applicable federal, state and local laws and regulations.

1.5 SUBMITTALS

- A. Product Data and Samples: Submit producer's or manufacturer's specifications and installation instructions for the following products to the Engineer for acceptance prior to the start of any work. Include laboratory test reports and other data to show compliance with Specifications, including specified standards. Submit samples where requested by Engineer.
1. High-strength bolts (each size, length and type), nuts, and washers, including manufacturer's certification of conformance for each and every lot. When requested by Engineer, submit samples to Testing Agency for testing prior to start of any work or delivery of materials to job site or stockyards.
 2. Shop-applied stud shear connectors.
 3. Reinforcing bar coupling devices which are to be shop welded to a structural steel. Submit welded sample for testing when requested.
 4. Deformed anchor bars to be stud welded to structural steel. Submit welded sample for testing when requested.
 5. Drilled-in anchors.
 6. Any other manufactured products specified under Part 2 - Products, or called for on the Drawings.
- B. Mill Certificates: Submit certified copies of producer's mill certificates for each piece of steel to be used. Reports shall include chemical and physical properties. See AISC specification section A3.1c.
- C. Deviations: Requests for deviations from Drawings or Specifications shall be submitted on Contractor's letterhead. Acceptance of shop drawings including deviations not detected during shop

drawing review will not relieve Contractor from responsibility to conform strictly to the Contract Documents. Deviations will be allowed only where permitted by Engineer in writing. Proposed deviations must be accompanied by documented and physical evidence, which will establish that its quality equals or exceeds the quality specified.

- D. Shop Drawings: Submit shop drawings to the Engineer for acceptance in accordance with the requirements of the Contract Documents. Engineer shall have ten business days to review submittal packages from day after submittal arrives in Engineer's office until day that submittal is sent returned by Engineer.
1. At least two weeks prior to the first shop drawing submittal, Contractor shall provide Engineer with a comprehensive list of all shop drawing submittals, and a schedule indicating when all submittals are to be sent to the Engineer. If Contractor deviates from this schedule, Engineer shall be allowed additional time to review shop drawings.
 2. Shop drawings furnished under this section shall be not less complete than indicated by the applicable procedures shown in AISC's "Detailing for Steel Construction", 2009. Shop drawings shall be prepared by competent engineering personnel under the supervision of an experienced Professional Engineer registered in the state of New York. As evidence of such, each and every shop drawing shall bear the seal and signature of said Engineer.
 3. Submit complete job standards prior to detailing individual members. Standards shall describe all repetitive work. Provide calculations upon request.
 4. Submit shop drawings to Engineer in coordinated packages so that all required information is in hand at time of review. Prior to resubmission of shop drawings, all changes from prior issue shall be clearly circled and identified. Do not fabricate before shop drawings have been reviewed and returned to Contractor marked either "No Exceptions Taken" or "Make Corrections Noted" only.
 5. Prepare, submit and keep up to date, a complete drawing index, cross-referencing assigned piece mark with the drawing number upon which the piece is detailed.
 6. Contractor shall coordinate and cross-check for accuracy, completeness and correct relationship to the work of other sections, each shop drawing prepared for the work of this Section, including each shop drawing prepared by subcontractors. Detail steel work so as not to interfere with the work of other trades. Engineer's review of shop drawings does not relieve Contractor from these responsibilities.
 7. Prior to sending submittals to Engineer, Contractor and Construction Manager (if applicable) shall coordinate and cross-check for accuracy and completeness each shop drawings prepared for work of this Section with the approved construction Documents and Specifications. Shop drawings shall bear the stamp of Contractor and Construction Manager indicating that this review has been performed. Engineer will not review submittals for which Contractor and Construction Manager have not performed this review.
 8. Prepare erection drawings to show clearly the size and location of each member, and the erection mark assigned to each member. Show each field connection complete with data and details necessary for assembling the structure. Direct attention to the possible need for special guying, bracing or shoring.
 9. Prepare anchor bolt, base plate and embedded plate erection drawings with complete dimensions. Provide to the concrete trade in advance of applicable concrete work.
 10. Submit, for review and acceptance, field work drawings depicting all field work required to accommodate field conditions.
 11. Shop drawings shall include plans, elevations, sections and complete details and be accurately dimensioned. Indicate size and grade of steel for each piece. Detail to accommodate Contractor's field measurements of supporting and adjoining construction. Contractor shall make a complete survey of all existing conditions prior to detailing.

12. Design of structural steel connections to plates or anchors embedded in concrete shall be based on the most severe combination of structural steel, concrete structure, and embedded item location tolerance.
 13. Identify the connection used at each location. Connections shall conform to controlling requirements given in the Drawings, specified herein, or required by the New York City Building Code. Proportion connections not completely detailed in the Drawings to resist loads and load combinations required by the Contract Documents or by the New York City Building Code. Provide temporary expansion joints in structural steel work and between the work of this Section and that of other sections providing support or restraint until such time as work is thoroughly stabilized. Close and secure such joints at that time.
 14. Indicate clearly the grade, size and number of bolts, the type, number, position and orientation of each washer and the size of each hole, whether slotted or round. Proportion connection details to ensure adequate wrench clearance for correct bolt tensioning sequences. Indicate method of tensioning for all high strength bolts.
 15. All welds shall be indicated by using symbols conforming to AWS A2.4 and shall indicate type, size, length, spacing, location, orientation, etc. as applicable. Complete and partial penetration welds shall be indicated by an AWS prequalified joint designation. In addition, for all penetration welds, the complete joint preparation and configuration shall be shown or indicated, including root opening, groove angle, root face, backing bar, etc. as applicable. Bevels shall be graphically detailed in large scale.
 16. Welding processes and electrodes shall be indicated on each shop drawing.
 17. Detail shear studs, deformed bar anchors, concrete reinforcing bar couplers and other items which are to be shop applied.
 18. Show and dimension holes and other work in the structural steel work required for work of other sections. Provide fieldwork drawings for holes not shown in shop drawings.
 19. Indicate all structural steel shelves required to support steel deck ends and edges at supporting beams, columns, and other structural steel elements.
 20. Detail cleaning and painting requirements, including identification of "no-paint" areas.
- E. Work engineered by Contractor: Submit, for record purposes, drawings and calculations as applicable, signed and sealed by a Professional Engineer registered in the state of New York, for all work engineered by the Contractor. Such work shall include all crane and crane-related engineering, shoring and bracing procedures and sequences, and any other areas noted on the Drawings or required by the New York City Building Code.

1.6 INSPECTION AND TESTING

- A. General: Owner will engage and pay for the services of an independent Testing Agency acceptable to the Engineer.
1. Contractor shall be responsible for providing the Testing Agency and Engineer with proper notice of the initiation of each phase and portion of work requiring testing or inspection. Written notice of commencement date shall be provided at least 5 working days prior to the start of shop work and the start of fieldwork. Subsequently, Contractor shall give a minimum of 24 hours verbal notice of work, or completion of work as applicable, requiring inspection and/or testing.
 2. Contractor shall furnish Testing Agency with a complete set of Construction Documents and Specifications, along with one copy of each accepted shop drawing bearing the Engineer's review stamp, mill test certificate and manufacturer's certification. Provide reasonable office space to Testing Agency at fabrication plants and at the site. Provide Testing Agency

personnel with convenient and safe access to the work and all reasonable assistance necessary to permit effective inspection and testing work.

3. Testing Agency may inspect and test materials and work at the source before shipment, as well as at the site before, during or at any time after installation. Deficient or incomplete work or materials shall be corrected or replaced, as directed by the Engineer, without additional costs or delays to the Owner.
4. The Testing Agency shall report directly to the Owner and Engineer the results of all testing and inspection by means of daily written reports. When any test or inspection reveals deficient or non-conforming work, Testing Agency shall notify Owner and Engineer immediately by means of a written report specially and clearly marked and identified to show deficient areas of work. Furthermore, the Testing Agency shall provide a table of all known members, noting when each piece was shop inspected, field inspected, any deficiencies and when the deficiencies were corrected. This table is to be provided to the Owner and Engineer with the weekly submission of daily reports. The format of this table is to be submitted to the Owner and Engineer for approval before inspection is begun.
5. Performance or waiving of inspection, testing or surveillance by Testing Agency for a given portion of the work will not relieve Contractor from responsibility to conform strictly to the requirements of the Contract Documents.
6. Where additional tests are deemed necessary by Engineer due to failure to pass tests, the cost of additional testing will be deducted from payments to Contractor.
7. If, due to errors by the Contractor or failure to perform his work in accordance with the Contract Documents, the Engineer must perform additional design or drafting work or review proposed solutions, the Contractor shall, through the Owner, reimburse the Engineer in accordance with the Engineer's current fee schedule plus out of pocket expenses incurred.

B. Shop Inspection and Testing: Work performed at fabrication plants shall be subject to inspection and testing as follows:

1. The Testing Agency shall review the fabricator's quality control program and make a written report of such.
2. Each piece of fabricated steel shall be examined for straightness, alignment and proper conformance to details on accepted shop drawings.
3. Mill certificates for all steel shall be examined.
4. Manufacturer's certifications for all bolting materials to be used in the shop shall be checked and lot numbers on containers shall be verified to match certificates.
5. High strength bolts and bolting operations shall be tested and inspected in accordance with part 1.06 E of this Section.
6. Welds and welding operations shall be tested and inspected in accordance with part 1.06 D of this Section.
7. Surface preparation and painting of all steel members where blast cleaning is specified shall be inspected. When requested by the Engineer, dry film thickness of paint layers shall be measured.
8. Stud welding operations shall be inspected and tested in accordance with AWS D1.1 Sections 7.7 and 7.8.

C. Field Inspection and Testing: Work performed in the field shall be subject to inspection and testing as follows:

1. Testing Agency shall verify that all steel pieces and connections are installed completely and properly in the correct location and manner in accordance with accepted shop drawings.

2. Lot numbers on containers of all bolting materials shall be verified to match submitted manufacturer's certifications. Manufacturer and grade markings on all components of bolt assemblies shall be verified.
 3. High strength bolts and bolting operations shall be tested and inspected in accordance with part 1.06 E of this Section.
 4. Welds and welding operations shall be tested and inspected in accordance with part 1.06 D of this Section.
 5. Steel exposed to the weather shall be inspected to verify that paint has been properly touched up at damaged or scratched areas.
- D. Welding: Inspection and testing of welds and welding operations shall be performed in accordance with AWS D1.1 Section 6 by the Testing Agency using AWS Certified Welding Inspectors.
1. Testing Agency shall verify:
 - a. Welding materials and equipment conform to the Contract Documents and AWS requirements and are used in correct positions and procedures.
 - b. Size, length and location of all welds, and correct and appropriate processes are used.
 - c. Welds are only made by welders certified by AWS for applicable process and position.
 - d. At appropriate intervals, performance of individual welders and preparation and fit-up of joints.
 2. All welds shall be visually inspected. Acceptance criteria shall be per AWS D1.1 as applicable.
 3. Fifty percent of all full and partial penetration welds, whether made in the shop or field, shall be ultrasonically tested, for 100% of their length, in accordance with AWS D1.1 Section 6 Part C as applicable.
 - a. If testing discloses a large ratio, in the opinion of the Engineer, of unacceptable welds, the required percentage shall be increased to 100% by the Engineer.
 - b. If, in the opinion of the Engineer, the testing consistently discloses acceptable welds, the percentage of tested welds may be reduced by the Engineer to a minimum of 25%.
 4. Fifty percent of all fillet welds, for 100% of their length, shall be tested by dye penetrant (ASTM E165) or magnetic particle (ASTM E709) method. Acceptance criteria shall be per AWS D1.1 as applicable.
 - a. If testing discloses a large ratio, in the opinion of the Engineer, of unacceptable welds, the required percentage shall be increased to 100% by the Engineer.
 - b. If, in the opinion of the Engineer, the testing consistently discloses acceptable welds, the percentage of tested welds may be reduced by the Engineer to a minimum of 25%.
 5. Welds which are not satisfactory or which are found to be defective by the Testing Agency shall be cut out and replaced by a satisfactory weld at no additional cost or delay to the Owner.

- E. High Strength Bolting: High strength bolts and bolting operations shall be tested and inspected as specified herein and in accordance with the RCSC Specification, Section 9.
1. Storage and Handling: The Testing Agency shall verify that bolting materials are properly stored and protected and at time of installation, are clean and free of rust and thread damage.
 2. Assembly: The Testing Agency shall verify that the proper bolting assembly is installed by checking size and grade of bolt, type and grade of nut, location and number of flat washers, and location, orientation and type of direct tension indicator (if used).
 3. Snugging: The Testing Agency shall verify that all bolts in a connection are properly snugged in accordance with RCSC Specification procedures and requirements of this Section before final tensioning of any bolt in a connection.
 4. Calibration: The Contractor shall provide a tension-measuring device (Skidmore-Wilhelm or similar), with proper calibration certification, at the jobsite at all times when bolts are being tensioned. At the start of work, when requested by the Engineer, and whenever deemed appropriate by the Testing Agency, installation procedures shall be confirmed by tensioning a representative sample of bolts in the tension measuring device. A representative sample shall consist of not less than three bolts of each size, grade, length and producer being used. Installation procedures shall achieve a tension not less than that given in Table 4 of the RCSC Specification within 10 seconds from a snug tight condition.
 5. Twist-off Bolts: Twist-off type bolts shall be inspected by observing installation procedures and by verifying that the splined end of every bolt shank has been properly broken off by the wrench chuck.
 6. Direct Tension Indicators: Bolts installed with direct tension indicators shall be inspected by observing installation procedures and by measuring the average residual gap of the DTI on every bolt in accordance with the manufacturer's recommendations.
 7. Turn-of-nut Installation: Bolts installed by the turn-of-nut method shall be inspected by measuring torque with a calibrated wrench. At the beginning of work, when deemed appropriate by the Testing Agency, whenever conditions such as lubrication or surface dirt change, and when a new or different manufacturer's material is being used, an inspecting torque shall be established. This shall be done by tensioning 5 bolts of each grade, diameter and manufacturer in a Skidmore-Wilhelm device to a tension not less than 105% of the minimum required and measuring torque with a properly certified calibrated wrench. The high and low values shall be discarded and the middle three averaged to establish an inspecting torque for each grade, diameter and producer. A minimum of 10 percent of the bolts, but not less than 2, in every connection shall be inspected. The Contractor shall provide the Skidmore-Wilhelm device, a calibrated wrenches, scaffolding and laborers as needed to perform such procedures at times requested by the Testing Agency.
 8. Verification Procedures: If the Testing Agency reasonably suspects that any bolts may not be properly tensioned, due to relaxation as a result of improper snugging or any other reason, the arbitration inspection method of the RCSC Specification, Section 9(b), shall be used, except that all bolts in the connection in question shall be checked. The Contractor shall provide a Skidmore-Wilhelm device, calibrated wrench, a laborer and scaffolding as required to safely and properly perform such verification.
 9. Laboratory Testing: High strength bolting materials shall be randomly tested throughout the project at times and in quantities chosen by the Engineer.
 - a. Tension tests of full-size bolts shall be performed to determine the proof load and ultimate tensile strength in accordance with ASTM F606 using Method 1, Length Measurement.

- b. Rockwell hardness of bolts shall be determined on the wrench flats after removal of surface material in accordance with ASTM F606. The reported hardness shall be the average of three hardness readings.
- c. Rockwell hardness of nuts shall be determined on the bearing face in accordance with ASTM F606.
- d. Surface hardness of hardened washers shall be determined in accordance with ASTM F606.
- e. In addition the surface hardness, the core hardness of 5/16 inch thick washers shall also be determined in accordance with ASTM F606.
- f. Direct tension indicators shall be tested in accordance with ASTM F959.
- g. If requested by the Engineer, chemical properties and dimensional tolerances of bolting materials may also be tested.

1.7 QUALITY ASSURANCE

- A. General: Contractor shall examine all Contract Documents and note any discrepancies and special construction problems requiring close coordination and exact time schedules; assume the responsibility of same and administer action such that the proper solution will result.
 - 1. Contractor's quality assurance procedures shall be effective and shall assure that all work fulfills the requirements of applicable provisions of the Contract Documents.
 - 2. Contractor shall maintain, on staff, sufficient office, field engineering, and field supervision staff to assure that all data and layout drawings for work of other Sections is transmitted to detailers to allow proper detailing of holes, penetrations, chases, and the like and to assure proper execution of the work in the field.
 - 3. Perform quality control functions required to achieve and to document that work conforms to the Contract Documents. Provide access to Contractor's quality control documents and reports upon request of Owner, Architect, Engineer or Testing Agency. Provide reasonable numbers of photocopies of specific quality control reports on request.
 - 4. Contractor and Construction Manager shall coordinate and schedule the work of this Section with the work of other Sections of this Specification in order to optimize quality and to avoid delay in overall job progress.
 - 5. Prior to starting applicable phases of the work of this Section, Contractor shall cooperate and coordinate with each trade affected by the work of this Section, including areas where work of other Specification Sections joins or relates to work of this Section. Contractor shall report unsatisfactory or nonconforming conditions to Engineer in writing prior to the start of work.
- B. Fabrication: The fabricator shall be certified by and use the AISC Quality Certification Program in establishing and administering a quality control program. Such program shall ensure that the work is performed in accordance with the Contract Documents.
- C. Erection: The erector shall maintain a quality control program to the extent necessary to ensure that all of the work is performed in accordance with the Contract Documents. The erector shall provide the equipment, personnel and management for the scope, magnitude and specified quality of the work.
- D. Qualifications: Throughout the progress of the work of this Section, provide at least one person who shall be thoroughly familiar with the specified requirements, completely trained and experienced in the necessary skills, and who shall be present at the site and shall direct all work performed under this Section.

1. The structural steel detailing firm shall be subject to acceptance by the Engineer. To ensure continuity, there shall be a single structural steel detailing firm. As a minimum requirement for acceptance, the structural detailing firm shall demonstrate experience in detailing of not less than five buildings of the type of this work and shall demonstrate in-house quality control procedures to the satisfaction of the Engineer.
 2. Fabricator shall have experience in the fabrication of structural steel for at least five buildings of the type of this work and shall possess all capabilities and qualifications required for AISC Type II Certification.
 3. Erector shall have experience in the erection of structural steel of at least five buildings of the type of this work.
 4. Welders and welding operators performing work under this Section shall be qualified in accordance with the building code and with applicable AWS requirements for each specific welding procedure and process which the welder will use in this work. When requested by the Engineer, Contractor shall require welders to be retested.
 5. Each welding procedure shall be described fully in the shop drawings and shall be designated prequalified under AWS D1.1 or shall be qualified in accordance with provisions of AWS D1.1 prior to use in the work. Each weld shall be visually inspected by the welder performing the work.
 - a. Contractor shall comply with AWS D1.1 Section 6.6.
- E. Contractor's Responsibilities: The Contractor shall be solely responsible for the items listed below. While the following list is not intended to be a complete listing of all responsibilities, it is provided to bring these items to the specific attention of the Contractor. Engineer's review of shop drawings or other submittals, or performance or waiving of inspection or testing, does not relieve Contractor from these responsibilities.
1. Safety and stability of the work. Construction sequences, whether stated or implied, are intended only to assist the Contractor in coordinating the work of the project.
 2. Fabrication procedures and the means, methods, techniques, sequences and procedures of construction.
 3. Correctness of dimensions and quantities, for the fitting to other or existing elements, for conditions to be confirmed and correlated at the site, and for the verification of the physical interrelationships of elements of the work.
 4. The amount, method of distributing, and proposed supplemental support of loads during construction. Construction loads shall not exceed the superimposed load which the member, with necessary supplemental support, is capable of carrying safely without damage.
 5. Obtain all field measurements required for proper fabrication and installation of work covered by this Section. Precise measurements are the responsibility of Contractor.
 6. Report unsatisfactory or non-conforming conditions to the Engineer in writing prior to the start of work.

1.8 MEASUREMENTS AND TOLERANCES

- A. Measurements: Lay out each part of the work in strict accordance with the Contract Documents. Precise measurements and layout are the sole responsibility of the Contractor.
1. Obtain all field measurements required for proper detailing, fabrication and installation of the work. Field verify all dimensions and locations of existing conditions shown on the Contract Documents. Where discrepancies exist, notify Engineer in writing, and by sketch when

- applicable, of discrepancies and proposed solutions to correct discrepancies.
2. Lay out the work from at least 2 pre-established benchmarks and axis lines, individually correct for length and bearing.
- B. Tolerances: Structural steel shall be fabricated and erected within the tolerances specified in the AISC Specification and Code, except that more restrictive tolerances, when specifically shown or noted in the Drawings or provided under this Specification, shall take precedence and shall apply to the work.
1. In lieu of the criteria given in Section M.4.4 of the AISC Specification, fit of finished compression splices shall be as follows: at least 65 percent of the contact area shall be in uniform bearing about the centroid of the bearing surface, with no separation greater than 1/32 inch. This requirement also applies to both shop and field connected base plates and bearing plates.

1.9 DELIVERIES, STORAGE AND HANDLING

- A. Anchor bolts, embedded plates, anchorage devices, and other items required to be embedded in cast-in-place concrete shall be delivered to the project site at times coordinated by Contractor to allow convenient installation and orderly cast-in-place concrete operations.
- B. Include setting drawings, templates, and directions for installation with all anchor bolts and with all other items or devices furnished and delivered to the project site for installation under other sections of this Specification.
- C. Structural steel members which are stored on or off the project site shall be supported above ground on platforms, skids or other supports so as to protect steel members from overstress, permanent deformation, corrosion and other damage.
- D. Materials shall be delivered to the site in the manufacturer's original and unopened containers and packaging, bearing labels as to type of material, brand name, and manufacturer's name. Delivered materials which are damaged or otherwise not suitable for installation, shall be removed from the jobsite and replaced with acceptable materials.
- E. Handling, shipping and erecting of shop painted steel pieces shall not be performed until the paint has dried thoroughly. Protect the paint from damage and keep individual members free from contact with the ground and with each other.
 1. Contractor shall furnish members in-place, fully painted, including all touch-up painting required as specified herein, at all locations where painting is required in the drawings by provisions of this Specification, and by the New York City Building Code.

1.10 DEFICIENT WORK

- A. Deficient work or any work failing to strictly conform to the Contract Documents shall be removed and replaced, or repaired if accepted by Engineer, at no cost to the Owner, Architect or Engineer.

1. Contractor shall prepare appropriate details and procedures to bring such work into conformance with the Contract Documents and submit to Engineer for review and acceptance. Contractor shall, through the Owner, reimburse the Engineer for time and expense incurred reviewing proposal procedures and details in accordance with the Engineer's current fee schedule.
 2. Nonconforming work may be rejected by Owner, Architect or Engineer at any time, regardless of prior acceptance in shop drawings, prior inspection, inclusion in inspection or test reports, or inclusions in certificates of payments.
- B. Deficient work shall include, but not be limited to:
1. Bent, twisted or warped pieces.
 2. Unauthorized cutting or reaming.
 3. Cracking, interior or surface defects.
 4. Painted or unpainted surfaces not sufficiently clean to finish coat.
 5. Workmanship not in accordance with the Drawings, with this Specification, with accepted samples, or with referenced codes or standards.
 6. Exceedance of tolerances.

PART 2 - PRODUCTS

2.01 STEEL

- A. Structural steel furnished for each location shall provide the minimum yield point given in the drawings, shall conform to the applicable ASTM steel specification, shall meet the requirements of the New York City Building Code, shall be suitable for use in welded structures and shall meet the requirements both of the drawings and of this Specification. All materials shall be new and of the best commercial quality. Steel produced to modified ASTM specifications shall not be used without the Engineer's prior written acceptance.

2.02 PAINT

- A. Shop and field-applied paint where designated in the Drawings, specified herein, and where required by the Building Code shall be selected from the following:
1. Alkyd primer:
 - a. Tnemec 10-99 by Tnemec Co.
 - b. Kem Kromik Primer by Sherwin-Williams Co.
 - c. Dulux 67-Y-834 by Dupont Co.
 - d. Carbocoat 150 or Carbocoat 818 by Carboline.
 - e. Amercoat 5105 by Ameron International.
 2. Zinc-rich primer:
 - a. 90-97 Tneme-Zinc by Tnemec Co.
 - b. Zinc Clad 5 by Sherwin-Williams Co.
 - c. Ganicin 347-Y-937 by Dupont Co.
 - d. Carbozinc 859 (class B Slip Critical) Epoxy Zinc-Rich by Carboline.
 - e. Amercoat 68HS by Ameron International.

3. Epoxy based:
 - a. Series 66 Hi-Build Epoxoline by Tnemec Co.
 - b. Tile-Clad II Epoxy by Sherwin-Williams Co.
 - c. Corlar 823 HB by Dupont Co.
 - d. Carboguard 890 Series or Carobguard 888 by Carboline.
 - e. Amercoat 385 by Ameron International.
4. Polyurethane:
 - a. Series 73 Endura-Shield III by Tnemec Co.
 - b. Hi-Solids Polyurethane by Sherwin-Williams Co.
 - c. Imron 333 by Dupont Co.
 - d. Carbothane 133 HB or Carobthane 833 by Carboline.
 - e. Amercoat 450 series (450HS, 450SA) by Ameron International.
5. Cold galvanizing:
 - a. ZRC Cold Galvanizing Compound by ZRC Products.
 - b. LPS Cold Galvanize by LPS Laboratories, Inc.
 - c. Carbozinc 4195 by Carboline.
6. Color of paint for steel exposed to view shall be selected by the architect.

2.03 WELDING MATERIALS

- A. Welding materials shall conform to AWS A5.1, A5.5, A5.17, A5.18, A5.20, A5.23, A5.28 or A5.29. Welding electrodes which have been wet or contaminated by grease or other substances deleterious to welding shall not be used in the work.
- B. Welding electrodes for welding of stainless steel to stainless or carbon steel shall be E308L.

2.04 STUDS

- A. Stud shear connectors and welding equipment used for installation shall conform to AWS D1.1.

2.05 BOLTING MATERIALS

- B. General: Bolts, nuts and washers for a given grade and diameter of bolt shall come from a single domestic manufacturer. For each diameter, only one grade may be used. Bolting materials shall be shipped to the jobsite in the bolt manufacturer's unopened containers with nuts and washers assembled and lot numbers marked on the container.
- C. Bolts: Bolts shall conform to ASTM F3125 except where ASTM A307 are specifically permitted in notes or details on the drawings and clearly designated in accepted shop drawings.
 1. Bolts shall be cold forged with rolled threads.
 2. Type 2 A325, Type 3 A325 or A490 bolts shall not be used.

- D. Nuts: Nuts for A325 bolts shall conform to ASTM A563 Grade C, D or DH or ASTM A194 Grade 2 or 2H. Nuts for A490 bolts shall conform to ASTM A563 Grade DH or ASTM A194 Grade 2H. Nuts for A307 bolts shall conform to ASTM A563 Grade A.
- E. Washers: Hardened washers shall conform to ASTM F436 and the requirements of the RCSC Specification.
- F. Direct Tension Indicators: DTI's shall conform to ASTM F959.
- G. Galvanized Steel Bolting Materials: Bolts shall conform to ASTM Type I, nuts shall be ASTM A563 Grade DH or A194 Grade 2H only. Bolts, nuts and washer shall be galvanized under the supervision of the bolt manufacturer in accordance with either ASTM B695 Class 50 or A153 Class C. Nuts must be tapped after hot dip galvanizing or slightly overtapped before wax or equal. The galvanized bolt, washer, nut assembly shall be tested by the bolt manufacturer in accordance with ASTM F3125 and shipped and stored in plastic bags in closed containers. Direct tension indicators for galvanized bolts shall be coated by the DTI manufacturer only, in accordance with ASTM B695 Class 50, and tested by the manufacturer after coating.
- H. Stainless Steel Bolting materials: Bolts shall conform to ASTM A193 Grade B8. Nuts shall conform to ASTM A194 Grade 8M.

2.06 GALVANIZING

- A. Galvanized steel members shall be hot-dipped galvanized in accordance with ASTM A123 All galvanized steel with coating to be repaired shall be done in accordance to ASTM A780.

2.07 LACQUER

- A. Milled Surfaces: Coat with Blue Lacquer by Varcroft Paint Co., or M-2658 Blue Lacquer by U.S. Steel Corp.

2.08 DRILLED-IN ANCHORS

- A. Adhesive Anchors: HVU Adhesive Anchors by Hilti, HIT HY 200 by Hilti, Epcon by ITW/Ramset, Ultrabond by U.S. Anchor, or other accepted by Engineer.
- B. Expansion Bolts: Kwik-Bolt III Anchors by Hilti, HSL Heavy Duty Sleeve Anchors by Hilti, Trubolt Wedge by ITW/Ramset, or other accepted by Engineer.

2.09 COUPLERS FOR CONCRETE REINFORCING BARS

- A. Concrete reinforcing bar couplers, which are to be welded to structural steel, shall be Lenton Half Couplers as manufactured by Erico Products, Grip Twist Coupler by BarSplice Products, or other accepted by Engineer.

2.10 STAINLESS STEEL

- A. Stainless steel shall be type 18-8 conforming to AISI Grade 304 or 316.

2.11 DEFORMED ANCHOR BARS

- A. Deformed bars to be stud welded to structural steel shall be D2L anchors as manufactured by Nelson Stud Division of TRW or other accepted by Engineer.

PART 3 - EXECUTION

3.01 PREPARATION FOR CONSTRUCTION

- A. Adjacent Structures: Contractor is solely responsible for the protection, shoring, bracing and stability of existing structures either on or adjacent to the site. Details and extent of such work shown on the Drawings are suggestions only; Contractor is to determine requirements and methods. All of the above operations shall be done under the supervision of a qualified Professional Engineer.
- B. Examination of Field Conditions: Contractor shall examine all existing surfaces, structures and the like which the work must attach to, clear or abut. Notify Engineer in writing of any conditions, which will delay or be detrimental to work. Start of work shall represent acceptance by Contractor of existing conditions as suitable for completing work as specified.
- C. Field Measurements: Contractor shall verify, by measurements at the site, all existing dimensions, which affect the work of this Section. Field dimensions varying from those on the design drawings or accepted shop drawings shall be brought to the Architect's and Engineer's attention in writing.

3.02 FABRICATION

- A. General: Structural Steel shall be shop fabricated in strict accordance with the shop drawings, certificates, and other submitted data accepted by the Engineer. Workmanship shall be of the best practice of relevant trades and shall be performed by skilled mechanics making use of modern tools and equipment in good condition. To the extent practical, fabrication shall be performed in the shop and not in the field.
- B. Straightening and Tolerances: Contractor shall straighten, square, flatten and torsionally align plates and shapes as necessary to provide fabricated elements within allowable tolerances as well as to provide correct alignment, good fit and uniform erection clearance, as applicable.
1. Fabrication tolerances shall not exceed those of the AISC Code.
 2. Material straightened prior to fabrication shall be examined carefully for signs of distress and for other defects before being placed in fabrication. Distressed or otherwise defective material shall not be used in the work. Straightening by the use of properly controlled heat will be permissible if done by personnel skilled in heat straightening, using equipment and techniques in accordance with written procedure documents and applicable detail sketches prepared by the fabricator and accepted by the Engineer.
 3. Sharp corners, projections, and similar rough or sharp surfaces or edges shall be eased and smoothed by grinding. Fabricated materials containing sharp kinks or bends shall be rejected.
- C. Cutting: Except where accepted by the Engineer, cutting shall be by machine. Gas cutting shall provide smooth, uniform, workmanlike surfaces and shall conform to the prescribed line. Minimum 1/2 inch radius of cut shall be provided at all reentrant corners. Gas cut surfaces shall be made uniform and notch-free by chipping, planing, grinding and welding as required.

- D. Finished Surfaces: Finishing shall be mean milled to ANSI 500 or smoother. Finished surfaces shall be protected by a corrosion inhibiting substance as provided herein. Plane contact surfaces of grillages and base plates. Mill edges of bearing stiffeners.
- E. Bolt Holes: Bolt holes shall be normal size unless specifically accepted by the Engineer. Do not make or enlarge holes by burning. Drill material where thickness exceeds the connector diameter and in all material thicker than 7/8 inch. Remove burrs from drilling operations. Elongated punch and die sets shall be used to punch elongated holes.
- F. Miscellaneous:
 - 1. Members shall not be shop or field spliced except where specifically accepted by the Engineer and detailed on shop drawings.
 - 2. Pipes, tubes and built-up box members shall be completely sealed with cap plates unless specifically designated otherwise in the Drawings.
 - 3. Curved members of rolled sections shall be bent to uniform smooth curvature by means acceptable to the Engineer.

3.03 ERECTION

- A. General: Erection of steelwork shall be performed by skilled workmen in accordance with the accepted shop drawings and certificates and shall conform strictly to the Contract Documents.
- B. Embedded Items: Furnish anchor bolts, embedded plates and any other items specified in this Section which are to be cast into concrete in a timely manner. Provide steel templates and layout drawings with setting instructions and tolerances.
- C. Shoring, Bracing and Guying: Contractor shall be solely responsible for stability and safety of the structure during the construction process. This responsibility includes any and all engineering for cranes, methods and sequences of erection, and temporary storage of materials such as metal decking.
 - 1. Provide temporary bracing as required in order to resist safely all imposed vertical and horizontal loads during construction and to maintain correct alignment. Design of temporary shoring, bracing and guying is the Contractor's sole and complete responsibility, including all details of installation and removal, methods, sequence and timing. Remove temporary members and their connections after structure is completed.
 - 2. Anchor bolts as shown in the Drawings are intended for requirements of the fully completed structure. Anchor bolt requirements for erection purposes and loadings shall be determined by the Contractor.
- D. Measurements and Tolerances: Contractor shall employ a licensed Surveyor experienced in surveying steel building frameworks and report all discrepancies to the Engineer. Contractor shall not proceed with erection until acceptable corrections have been made. Contractor's steel surveys shall establish permanent bench marks as necessary, shall check elevations of bearing surfaces and locations of anchor devices and shall provide data during the course of the Work and a final survey showing the E-W, N-S and elevation position of the work points of each steel frame, truss and other major member as compared to theoretical location. Such surveys shall be submitted for record at the completion of

steel erection and at times requested by the Engineer.

1. Erection tolerances shall not exceed those of the AISC Code.
- E. Compression Splices: Fastening of compression splices and joints shall be performed after the abutting surfaces have been brought uniformly into contact. Bearing surfaces shall be cleaned before the parts are assembled.
1. At least 65 percent of the contact area shall be in uniform bearing about the centroid of the bearing surface, with no separation greater than 0.02 inches, except locally at flange toes or corners which may be separated 0.03 inches without need for corrective measures. These requirements apply to both shop and field connected base plates and bearing plates. The above requirements specifically supersede Section M4.4 of the AISC Specification.
- F. Field Modifications and Corrections: Field modifications and/or correction of fabrication or detailing errors shall not be made without the prior acceptance of field work drawings by the Engineer.
1. Bolt holes shall not be cut or enlarged with a gas torch.
 2. Field cut beam openings shall only be made where expressly permitted by the Engineer. Openings to be cut with a mechanically guided torch after which all edges are to be ground smooth with proper radii at corners. Required reinforcing is to be placed prior to cutting opening.

3.04 BOLTING

- A. General: Bolting procedures shall meet all of the requirements of the RCSC Specification and those given herein.
1. Bolts, nuts and washers, at time of tightening, shall be clean, rust-free and free from thread damage.
 2. Impact wrenches shall be of adequate capacity and sufficiently supplied with air to perform the required tightening of each bolt within 10 seconds.
- B. Acceptable Methods of Installation: All ASTM A325 and A490 bolts shall be fully tensioned to the minimum values given in Table 7 of the RCSC Specification unless specifically permitted otherwise by the Engineer in writing.
1. Bolts shall be tensioned using one of the following methods, as defined by the RCSC Specification and requirements herein, within the limitations given:
 - a. Twist-off type bolts, for diameters not exceeding one inch.
 - b. Direct tension indicators.
 - c. Turn-of-nut, provided that every bolt in every connection is marked with white or yellow keel after snugging and prior to final tightening ("match marking"). Turn-of-nut may not be used for bolts larger than one inch diameter.
 2. ASTM A307 bolts shall be tightened using full manual effort on a suitable wrench. After installation, score threads to prevent nuts from loosening.

- C. Snugging: Regardless of the installation method being used, connections shall be properly "snugged" prior to final tensioning of any bolt in the connection. Snug tight is defined as the condition where all plies of the connection are in firm contact. Snugging of bolts shall progress systematically from the most rigid part of the connection to the free edges. Impact wrenches shall be used on larger connections if manual effort on spud wrenches is not sufficient to bring plies together.
- D. Twist-off Type Bolt Installation: Connections shall be properly snugged prior to tensioning of any bolt, which breaks the splined tip. A hardened washer shall be provided under the nut.
- E. Installation with Direct Tension Indicators: Tensioning methods, number, thickness, location, orientation and type of washers, procedures and measurements shall be in strict accordance with the manufacturer's latest printed instructions.
1. DTI's shall be provided in addition to all other washers required.
 2. Impact wrenches used shall be those recommended by the DTI manufacturer for the grade and size of bolt being installed and shall be in good repair and sufficiently supplied with compressed air.
 3. Protrusions of the DTI shall bear only against the underside of the bolt head or against a hardened 3/16-inch thick hardened washer, as applicable.
 4. Bolts larger than one-inch diameter shall be lubricated with Johnson's Stick Wax 140 on threads and face of turned element prior to tightening.
 5. Connections shall be properly snugged prior to final tensioning of any bolt, which flattens the protrusions of the DTI.
 6. In calibration procedures, the DTI need only indicate a tension of 100 percent of the minimum specified tension and not 105 percent as required by Section 8.2.4 of the RCSC Specification.
- F. Installation by Turn-of-Nut: Installation shall be in strict accordance with the RCSC Specification and the additional requirements given herein.
1. A hardened washer shall always be provided under the bearing face of the turned element (nut or bolt head).
 2. Bolts shall be properly snugged and match marked prior to final tensioning of any bolt in a connection.
 3. During tightening of bolts, the unturned element shall not be allowed to rotate. The unturned bolt element shall be held without rotation using the correct size spud wrench or other suitable correct size of open end, closed end or socket wrench.
- G. Oversized and Slotted Holes: Washers, plate washers and/or continuous bars shall be provided for ASTM A325 and A490 bolts in accordance Section 6 of the RCSC Specification.
- H. Reuse of Bolts: ASTM A490 bolts and galvanized ASTM A325 bolts, if completely or partially untorqued, shall not be reused. ASTM A325 bolts may be reused only with specific written acceptance by the Engineer.
- I. Field Modifications or Corrections: Unfair holes shall not be enlarged by burning or drifting alone. Enlarge holes where necessary and permitted by flame piercing and reaming or by reaming alone or by other means accepted by the Engineer. Holes after enlargement shall be true round holes normal to the surfaces joined. Increase bolt size to fill enlarged and reamed holes.
- J. Galvanized Bolts: Galvanized bolts shall be provided wherever the connection is exposed to the

weather.

1. Bolt threads and the face of the turned element shall be lubricated with Johnson's Stick Wax 140 prior to installation.

3.05 WELDING

A. General: Welding processes and materials shall comply with AWS D1.1 and any additional requirements specified herein.

B. Quality Control and Certifications: Quality of all welds shall conform to AWS D1.1 for the type of weld and specified method of inspection.

1. All welds shall be visually inspected by the welder who made the weld.
2. Welds shall only be made by welders with AWS certification, and any local building code license if required, for the type of weld, welding process and position of the weld being made.
3. Field welds shall be subject to the same acceptance criteria as shop welds.
4. Cracking or incomplete penetration shall be cause for rejection of each weld possessing such defects, regardless of other acceptance or rejection criteria.
5. Base metal containing gross discontinuities, before or after welding, or lamellar tearing after welding, shall be repaired in accordance with accepted procedures or shall be discarded and replaced.
6. The Contractor shall comply with the requirements of AWS Article 6.6.

C. Materials and Processes: Welding materials and processes shall be selected from those specified herein and shall conform to accepted welding procedure specifications.

1. Complete and partial penetration welds shall be made using only AWS prequalified procedures following all requirements for joint preparation, fit up, orientation, etc.
2. Welding electrodes or flux contaminated by deleterious substances or moisture shall not be used and shall be removed promptly from the work location. Low hydrogen electrodes which cannot be used promptly after opening of hermetically sealed containers shall be stored in electric holding ovens at 250°F (minimum).

D. Preheating: Welding shall be performed on material preheated to a temperature above the dew point, regardless of other preheating requirements.

1. Joints in which material is two inches or more in thickness shall not have the weld interrupted after operation has started, unless at least 2/3 of its size, for its full length, has been completed without an interruption of more than one hour. Welding may be interrupted for longer periods, provided the preheat temperature is maintained for full length of joint for the entire time welding is interrupted.

E. Miscellaneous:

1. Sizes of fillet and partial penetration welds shall equal or exceed minimums required by the AISC Specification regardless of all other requirements.
2. All backing bars shall be continuous across the entire length of the weld.
3. Slag shall be removed from all welds for inspection.

4. Shop stud welding of headed stud shear connectors and deformed anchor bars shall be in accordance with Paragraph 3.07 A of this Section.
5. Exposed exterior structural steel shall have all joints seal welded.
6. Welding of ASTM A6 Group 4 and 5 rolled shapes spliced in tension shall conform to AISC specification Section J1.7.

3.06 FINISHING, PAINTING & GALVANIZING

- A. General: Steel work shall be cleaned, painted or galvanized as provided herein. Cleaning and priming shall be done in the shop, intermediate and top coats may be done in the shop or in the field unless otherwise specified.
1. Steel which is to be encased in concrete shall be cleaned to meet the requirements of SSPC SP-2, by wire brush or other means at the option of the contractor. Reclean after erection to the extent required to achieve the original condition.
 2. Steel which is to be enclosed and not spray fireproofed shall be cleaned to meet the requirements of SSPC SP-3 and shop sprayed with an alkyd primer, not less than 2.5 mils nor more than 3.5 mils dry film thickness.
 3. New steel which is to be exposed to weather shall be cleaned to meet the requirements of SSPC SP-6, shop sprayed with zinc-rich primer not less than 2.5 nor more than 3.5 mils dry film thickness (DFT), intermediate spray coated with epoxy-based paint not less than 4.0 nor more than 6.0 mils DFT, and top coated with polyurethane paint not less than 3.0 nor more than 5.0 mils DFT.
 4. Existing steel which will be permanently exposed to weather shall be cleaned to meet the requirements of SSPC SP-3 and coated twice with Carboline Rustbound Penetrating Sealer or Carboguard 954 followed by epoxy-based paint, for a total coating dry film thickness not less than 7.0 mils nor more than 15.0 mils dry film thickness. Test topcoat over existing coatings to verify compatibility. If total system dry film build excess 15.0 mils, including existing paints, then removal of this high thickness must be conducted.
 5. New steel exposed to the weather but not painted, and where noted in the Drawings, shall be hot-dip galvanized.
- B. Painting: Paint shall be applied thoroughly and evenly without sags or holidays by suitable spray equipment in strict accordance with the paint manufacturer's printed instructions. Provide a dry film thickness within the range specified herein, including around outside corners or other abrupt changes in surface profile.
1. Paint shall be applied only to dry surfaces and only at times when steel surface temperatures are at least 5° F above the dew point and above the minimum temperature recommended by the manufacturer for the particular paint.
 2. For alkyd primer, epoxy-based paint and polyurethane, surfaces to be subsequently bolted or welded shall be blocked out for a minimum of 2 inches each direction from edge of bolt holes or welds.
 3. For Zinc-rich primer, surfaces to be subsequently welded shall be blocked out. Surfaces to be bolted shall not be blocked if slip-critical Class B zinc-rich primer is utilized (no topcoat).
 4. Contractor shall reasonably protect painted surfaces from damage, abrasion and soiling.
 5. Sharp edges, such as those created by flame cutting or shearing, shall be broken and rounded prior to surface preparation. Breaking the edge can be accomplished by a single pass of a grinder in order to flatten the edge.

- C. Field Touch-Up: Field touch-up shall be provided at all blocked areas and points of damage, including bolts and welds installed after coating.
1. Touch-up for one coat treatment shall be power tool cleaning to SSPC SP-3 and one coat of zinc-rich primer.
 2. Touch-up for two coat treatment shall be power tool cleaning to SSPC SP-3, one coat of zinc-rich primer and one coat of epoxy-based paint.
 3. Touch-up for three coat treatment shall be power tool cleaning to SSPC SP-3, one coat of zinc-rich primer and two coats of polyurethane paint.
 4. Touch-up for galvanized steel shall be power tool cleaning to SSPC SP-3 and painting with cold galvanizing compound.

3.07 MISCELLANEOUS

- A. Stud Welding: Use automatic stud welding systems in strict accordance with the manufacturer's instructions to weld all studs and deformed anchor bars installed in the shop. Prepare structural steel surfaces as recommended by the stud shear connector or anchor bar manufacturer. Fillet welding shall be used for repair welding only. All welding ferrules shall be broken and removed to allow visual inspection of the stud welds. All weld repairs to stud welds shall be made to the extent required by AWS D1.1.
- B. Drilled-In-Anchors: Drilled-in anchors into concrete or masonry shall be installed in strict accordance with the manufacturer's instructions. Drilled holes shall be cleaned thoroughly with compressed air blown into the bottom of the drilled hole with a tube.
- C. Rebar Couplers: Concrete reinforcing bar couplers welded to structural steel shall be installed in strict accordance with the manufacturer's instructions and AWS D1.1.

END OF SECTION 051200

SECTION 083919 – FLOOD PANELS AND BARRIERS

PART 1 GENERAL

1.1 SUMMARY

A. The Contractor shall furnish, fabricate and install flood panels and barriers. The flood panels and barriers shall be provided complete with all accessories and fastenings required for a satisfactory installation.

B. An index of the Articles in this Section is given below for convenience:

<u>Article</u>	<u>Title</u>	<u>Page</u>
		083919-
PART 1	GENERAL	1
1.01	Summary.....	1
1.02	Payment	1
1.03	References	1
1.04	Design Requirements.....	1
1.05	Quality Assurance and Qualifications	2
1.06	Submittals	2
1.07	Delivery, Storage and Handling	3
PART 2	PRODUCTS	3
2.01	Manufacturers.....	3
2.02	Materials/Equipment (Factory Fabricated Stackable Barrier).....	3
2.03	Materials/Equipment (Factory Fabricated Flood Panel).....	4
2.04	Source Quality Control.....	5
PART 3	EXECUTION	5
3.01	Factory Testing/Quality Control.....	5
3.02	Site Inspection & Field Verification.....	5
3.03	Installation	6

1.2 PAYMENT

C. Payment for Work associated with this Section shall be made in accordance with each Job Order that includes such Work, and the Contract.

1.3 REFERENCES

- D. FEMA Technical Bulletin 3-93 - Non-Residential Flood Proofing.
- E. AWS Structural Welding Code.
- F. ASME Liquid Penetrant Inspection Section VIII.
- G. SEI/ASCE 24 Floor Resistant Design and Construction.

1.4 DESIGN REQUIREMENTS

H. The Contractor shall supply the fabricated flood barriers and panels as per the Contract Drawings and as follows:

- 1. Design watertight planks to perform under hydrostatic loads (and hydrodynamic or other loads as specified) to control short-term load pressures indicated. All

water pressure loads and operating loads are transferred to the flood wall structure.

2. Design loads considered shall be in accordance with FEMA Technical Bulletin 3-93 - Non-Residential Flood Proofing and SEI/ASCE 24 Flood Resistant Design and Construction Requirements.

1.5 QUALITY ASSURANCE AND QUALIFICATIONS

I. Shop Inspections

1. Shop inspections may be made by Battery Park City Authority or its representative.
2. The Contract shall give ample notice to the Engineer prior to the beginning of any fabrication, so that the inspection may be made.
3. The Battery Park City Authority and/or its representative may conduct the following quality assurance inspection operations at the manufacturer's facility:
 - a. Visual inspection of welding, as per AWS D1.6.
 - b. Visual and dimensional inspection welding of completed work.

- J. **Manufacturer Experience:** The manufacturer shall provide information supporting at least five (5) years of experience in the design and manufacture of the product specified.

1.6 SUBMITTALS

- K. The Contractor shall prepare and submit to the Engineer for approval, shop drawings and other material required to substantiate conformance in accordance with Vol. III General Requirement 01330 – Submittal Procedures.
- L. Shop drawings shall be sealed and signed by a NYS Registered Professional Engineer.
- M. Shop drawings shall include but not be limited to:
1. Dimensioned plans and elevations, sections, connections and anchorage, and parts list.
 2. Calculations: Submit calculations, approved by a NYS Registered Professional Engineer, to verify the barrier's ability to withstand the design pressure loading.
 3. Certified weld inspection reports.
 4. Copies of certified materials test reports, both chemical and physical and test report for susceptibility to intergranular corrosion of the stainless steel material, as applicable.
 5. The manufacturer's specifications, load table, installation instructions, setting drawings and templates for location and installation of miscellaneous metal items, appurtenances and anchorage devices.
- N. The following samples shall be furnished: Representative samples of bolts, anchors, inserts, gasket types, floor barrier finishes, flood barrier numbering tags

as requested by the Engineer. The Engineer's review shall be for type and finish only.

- O. List of material manufacturers with the components provided, including but not limited to mill test reports.

1.7 DELIVERY, STORAGE AND HANDLING

- P. Shall be transported, handled and stored without being over-stressed, deformed or otherwise damaged and as per the manufacturer's instructions and recommendations.
- Q. Coatings shall be applied in the shop; the units are to be delivered ready for installation.

PART 2 PRODUCTS

1.8 MANUFACTURERS

- A. Flood Panels and Barriers shall be manufactured by:
 - 1. Presray Corporation, Wassaic, NY
 - 2. Flood Control International, NY
 - 3. Flood Panel, Jupiter, FL
 - 4. PS Flood Barriers, Grand Forks, ND
 - 5. Hydro Gate, New York, NY
 - 6. Flood Barrier Inc., Miami, FL
 - 7. Or approved equal.

1.9 MATERIALS/EQUIPMENT (FACTORY FABRICATED STACKABLE BARRIER)

- B. Flood barrier shall be Model Fastlog STM-SD as manufactured by Presray Corporation, Model FloodLog Flood Barriers as manufactured by Flood Panel, or approved equal.
- C. Stop Logs: aluminum channels or planks.
- D. Frames: Jamb Extrusion; no sills necessary unless mandated by the manufacturer's engineer. Steel jambs optional for certain conditions.
- E. Finish: Stop logs mill-finish aluminum; jambs mill-finish aluminum. Stop log assembly including jambs shall be clear anodized-finish aluminum.
- F. Gasket: High-density closed cell neoprene sponge with skin, retained in the stop logs and jambs.
- G. Hardware: compression brackets; hold down brackets; turn knobs.
- H. Design:

1. Stop logs shall be designed with a minimum 2:1 factor of safety based on material yield strength, and shall provide an effective seal against the design flood level.
2. Frame shall have mounting holes for concrete anchors and bolts (options available include epoxy anchors for block walls, and studs for embedment in concrete).
3. The barrier shall be designed such that it attaches to the wet side of the building envelope and load is transferred from the flood panel or barrier to the existing construction through bearing.
4. Stop logs shall have lifting handles for ease of operation during deployment. Stop logs shall have optional use of installation equipment.
5. Lifting device shall be provided to remove and install the stop logs as specified herein. The lifters shall be extendible so that they will function with different stop log plank lengths. The device shall be oriented in its position by the stop log plank guides and shall be capable of securing and releasing the stop logs with the use of a lanyard from the operating floor.
6. Stop logs shall be stenciled with identification for ease of use in deployment. Bottom logs shall be stenciled

1.10 MATERIALS/EQUIPMENT (FACTORY FABRICATED FLOOD PANEL)

I. Flood barrier shall be Model CG22 as manufactured by Presray Corporation, Flood Panel System/Puddle Panel as manufactured by Flood Panel or approved equal.

J. Materials:

1. Panel: 6061 – T6 aluminum plate.
2. Finish: Bright Aluminum Finish.
3. Gasket: Low compression set type molded (extruded gaskets not acceptable).
4. Hardware
 - a. Attachment bolts: stainless steel bolts.
 - b. Grab Handles: Welded lift attachments on face of panel.
 - c. Design.

K. Flood barrier(s) shall be designed with a minimum 2:1 factor of safety based on material yield strength, and shall provide an effective seal against the design flood level.

L. Panel shall be designed for installation using expansion anchors and bolts.

1.11 FLOOD PANEL AND BARRIER STORAGE

M. The Contractor shall install flood panel and barrier storage containers.

N. Location and details of storage containers shall be coordinated with the Operating Bureau and be submitted to the Engineer for approval prior to installation.

- O. Storage shall consist of but not limited to the following:
1. Storage containers with interior racking systems along the interior of the container, capable of withstanding equipment weight.
 2. Storage containers shall be compatible with forklift access.
 3. Storage locations within storage container shall be labeled clearly to indicate the name and deployment location of the flood barriers.

1.12 SOURCE QUALITY CONTROL

- P. The manufacturer shall have and perform quality control operations based on a written quality control program that includes the following:
1. Review and rejection of incoming materials based on certified test reports and visual inspections.
 2. Frequency of inspection and inspection requirements.
 3. All quality control inspection reports shall be dated and maintained by the flood panel/barrier manufacturer for a minimum period of seven years.
 4. All prototype test records for custom flood panels/barriers and all production test records shall be dated and maintained by the flood panel/barrier manufacturer for a minimum period of seven (7) years.
 5. All prototype test records for the manufacturer's standard flood panel/barrier designs shall be permanently archived.

PART 3 EXECUTION

1.13 FACTORY TESTING/QUALITY CONTROL

- A. Finished assembly or assembly similar in design shall be factory leak tested to verify that it will withstand the design hydrostatic pressure.
- B. All welds on flood barrier assemblies that may be potential "leak path" shall be liquid penetrant inspected in accordance with ASME section VIII Div. of Appendix 8.
- C. The Contractor shall conduct a full-size test on one pre-engineered modular flood barrier, using the project's design loading criteria and performance criteria. It is acceptable to conduct the test at an offsite facility, providing that similar boundary conditions and criteria stated are followed.
- D. Contractor shall correct any deficiencies revealed during testing at no additional cost to the Battery Park City Authority. Additional testing and inspection shall be at the Contractor's expense to demonstrate compliance with the above requirements.

1.14 SITE INSPECTION & FIELD VERIFICATION

- E. The Contractor shall verify that the area to receive the barrier is properly prepared and set to the proper elevation.

- F. Contract shall meet the requirements of the manufacturer's installation recommendations and approved shop drawings.
 - G. Do not begin installation until substrates have been properly prepared.
 - H. If substrate preparation is the responsibility of another installer, notify Architect of unsatisfactory preparation before proceeding.
 - I. Field Testing:
 - 1. Perform visual dry test for gasket alignment, continuity contact and pre-compression.
 - 2. Construct temporary water barrier and test installed flood barrier.
 - 3. The Contractor shall conduct a full-size test on one of the gates fabricated for the project using the project design hydrostatic and equivalent hydrodynamic load criteria – impact can be ignored for the test.
 - 4. The barrier selected for testing should be representative of the most common conditions present in the final design. It is acceptable to conduct the test at the project site or at an offsite facility using similar boundary conditions.
 - 5. The test leakage rate must be less than or equal to 0.1 gallons of water per minute per linear foot of sealed perimeter.
 - 6. Contractor shall correct any deficiencies revealed during testing at no additional cost to Battery Park City Authority. Additional testing and inspection shall be at the Contractor's expense to demonstrate compliance with the above requirements.
 - 7. Qualified factory representative shall provide eight (8) hours of training for facility Battery Park City Authority personnel. Representative shall complete a Certification of Proper Installation and provide copies to the Battery Park City Authority, Engineer, Contractor, and Manufacturing Facility.
 - J. Products to be operated and field verified including the sealing surfaces to assure that they maintain contact at the correct sealing points.
 - K. Verify that hinging and latching assemblies operate freely and correctly.
 - L. Verify all anchorage is in accordance with manufacture's installation instructions and applicable data sheets.
- 1.15 INSTALLATION
- M. Maintain environmental conditions (temperature, humidity, and ventilation) within limits recommended by the manufacturer for optimum results. Do not install products under environmental conditions outside the manufacturer's absolute limits.
 - N. Coordinate Work with other operations and installation of adjacent materials to avoid damage.

- O. Install in accordance with the manufacturer's installations instructions, approved shop drawings, shipping, handling, and storage instructions, and product carton instructions for installation.
- P. Flood panel or barrier shall be installed on the wet side of the building envelope
- Q. Flood panel/barrier(s) and their components shall be adjusted for proper alignment and operation.
- R. Touch-up, repair or replace damaged installed products or components.
- S. Clean all sealing surfaces.
- T. Protect installed products until completion of project.

END OF SECTION 083919

THIS PAGE INTENTIONALLY LEFT BLANK

SECTION 099113 - EXTERIOR PAINTING

PART 1 - GENERAL

1.1 RELATED DOCUMENTS

- A. Drawings and general provisions of the Contract, including General and Supplementary Conditions and Division 01 Specification Sections, apply to this Section.

1.2 SUMMARY

- A. Section includes surface preparation and the application of paint systems on the following exterior substrates:
 - 1. Concrete.
 - 2. Steel and iron.
- B. Related Requirements:
 - 1. Section 051200 "Structural Steel Framing" for preparation of metal substrates.

1.3 DEFINITIONS

- A. MPI Gloss Level 1: Not more than five units at 60 degrees and 10 units at 85 degrees, according to ASTM D 523.
- B. MPI Gloss Level 3: 10 to 25 units at 60 degrees and 10 to 35 units at 85 degrees, according to ASTM D 523.
- C. MPI Gloss Level 4: 20 to 35 units at 60 degrees and not less than 35 units at 85 degrees, according to ASTM D 523.
- D. MPI Gloss Level 5: 35 to 70 units at 60 degrees, according to ASTM D 523.
- E. MPI Gloss Level 6: 70 to 85 units at 60 degrees, according to ASTM D 523.
- F. MPI Gloss Level 7: More than 85 units at 60 degrees, according to ASTM D 523.

1.4 ACTION SUBMITTALS

- A. Product Data: For each type of product. Include preparation requirements and application instructions.
 - 1. Include printout of current "MPI Approved Products List" for each product category specified, with the proposed product highlighted.
 - 2. Indicate VOC content.

- B. Samples for Initial Selection: For each type of topcoat product.

1.5 MAINTENANCE MATERIAL SUBMITTALS

- A. Furnish extra materials that match products installed and that are packaged with protective covering for storage and identified with labels describing contents.
 - 1. Paint: 5 percent, but not less than 1 gal. of each material and color applied.

1.6 QUALITY ASSURANCE

- A. Mockups: Apply mockups of each paint system indicated and each color and finish selected to verify preliminary selections made under Sample submittals and to demonstrate aesthetic effects and set quality standards for materials and execution.
 - 1. Architect will select one surface to represent surfaces and conditions for application of each paint system.
 - a. Vertical and Horizontal Surfaces: Provide samples of at least 100 sq. ft..
 - 2. Final approval of color selections will be based on mockups.
 - a. If preliminary color selections are not approved, apply additional mockups of additional colors selected by Architect at no added cost to Owner.
 - 3. Approval of mockups does not constitute approval of deviations from the Contract Documents contained in mockups unless Architect specifically approves such deviations in writing.
 - 4. Subject to compliance with requirements, approved mockups may become part of the completed Work if undisturbed at time of Substantial Completion.

1.7 DELIVERY, STORAGE, AND HANDLING

- A. Store materials not in use in tightly covered containers in well-ventilated areas with ambient temperatures continuously maintained at not less than 45 deg F.
 - 1. Maintain containers in clean condition, free of foreign materials and residue.
 - 2. Remove rags and waste from storage areas daily.

1.8 FIELD CONDITIONS

- A. Apply paints only when temperature of surfaces to be painted and ambient air temperatures are between 50 and 95 deg F.
- B. Do not apply paints in snow, rain, fog, or mist; when relative humidity exceeds 85 percent; at temperatures less than 5 deg F above the dew point; or to damp or wet surfaces.

PART 2 - PRODUCTS

2.1 MANUFACTURERS

- A. Sherwin Williams.
- B. Approved equal.
- C. Products: Subject to compliance with requirements, provide product listed in the Exterior Painting Schedule for the paint category indicated.

2.2 PAINT, GENERAL

- A. MPI Standards: Products shall comply with MPI standards indicated and shall be listed in its "MPI Approved Products Lists."
- B. Material Compatibility:
 - 1. Materials for use within each paint system shall be compatible with one another and substrates indicated, under conditions of service and application as demonstrated by manufacturer, based on testing and field experience.
 - 2. For each coat in a paint system, products shall be recommended in writing by topcoat manufacturers for use in paint system and on substrate indicated.
- C. Colors: As selected by Architect from manufacturer's full range .

2.3 PRIME COAT

- A. Fast-cure polyamide epoxy.
- B. Product: Macropoxy 646-100 Fast Cure Epoxy, as manufactured by Sherwin Williams.
- C. Finish: Smei-gloss.

2.4 TOP COAT

- A. Polyester modified, aliphatic, acrylic polyurethane.
- B. Product: Acrolon 218 HS Acrylic Polyurethane as manufactured by Sherwin Williams.
- C. Finish: Semi-gloss.

2.5 SOURCE QUALITY CONTROL

- A. Testing of Paint Materials: Owner reserves the right to invoke the following procedure:

1. Owner will engage the services of a qualified testing agency to sample paint materials. Contractor will be notified in advance and may be present when samples are taken. If paint materials have already been delivered to Project site, samples may be taken at Project site. Samples will be identified, sealed, and certified by testing agency.
2. Testing agency will perform tests for compliance with product requirements.
3. Owner may direct Contractor to stop applying paints if test results show materials being used do not comply with product requirements. Contractor shall remove noncomplying paint materials from Project site, pay for testing, and repaint surfaces painted with rejected materials. Contractor will be required to remove rejected materials from previously painted surfaces if, on repainting with complying materials, the two paints are incompatible.

PART 3 - EXECUTION

3.1 EXAMINATION

- A. Examine substrates and conditions, with Applicator present, for compliance with requirements for maximum moisture content and other conditions affecting performance of the Work.
- B. Maximum Moisture Content of Substrates: When measured with an electronic moisture meter as follows:
 1. Concrete: 12 percent.
- C. Verify suitability of substrates, including surface conditions and compatibility, with existing finishes and primers.
- D. Proceed with coating application only after unsatisfactory conditions have been corrected.
 1. Application of coating indicates acceptance of surfaces and conditions.

3.2 PREPARATION

- A. Comply with manufacturer's written instructions and recommendations in "MPI Architectural Painting Specification Manual" applicable to substrates and paint systems indicated.
- B. Remove hardware, covers, plates, and similar items already in place that are removable and are not to be painted. If removal is impractical or impossible because of size or weight of item, provide surface-applied protection before surface preparation and painting.
 1. After completing painting operations, use workers skilled in the trades involved to reinstall items that were removed. Remove surface-applied protection.
- C. Clean substrates of substances that could impair bond of paints, including dust, dirt, oil, grease, and incompatible paints and encapsulants.
 1. Remove incompatible primers and reprime substrate with compatible primers or apply tie coat as required to produce paint systems indicated.

- D. Concrete Substrates: Remove release agents, curing compounds, efflorescence, and chalk. Do not paint surfaces if moisture content or alkalinity of surfaces to be painted exceeds that permitted in manufacturer's written instructions.
- E. Shop-Primed Steel Substrates: Clean field welds, bolted connections, and areas where shop paint is abraded. Paint exposed areas with the same material as used for shop priming to comply with SSPC-PA 1 for touching up shop-primed surfaces.

3.3 APPLICATION

- A. Apply paints according to manufacturer's written instructions and recommendations in "MPI Architectural Painting Specification Manual."
 - 1. Use applicators and techniques suited for paint and substrate indicated.
 - 2. Paint surfaces behind movable items same as similar exposed surfaces. Before final installation, paint surfaces behind permanently fixed items with prime coat only.
- B. If undercoats or other conditions show through topcoat, apply additional coats until cured film has a uniform paint finish, color, and appearance.
- C. Apply paints to produce surface films without cloudiness, spotting, holidays, laps, brush marks, roller tracking, runs, sags, ropiness, or other surface imperfections. Cut in sharp lines and color breaks.

3.4 CLEANING AND PROTECTION

- A. At end of each workday, remove rubbish, empty cans, rags, and other discarded materials from Project site.
- B. After completing paint application, clean spattered surfaces. Remove spattered paints by washing, scraping, or other methods. Do not scratch or damage adjacent finished surfaces.
- C. Protect work of other trades against damage from paint application. Correct damage to work of other trades by cleaning, repairing, replacing, and refinishing, as approved by Architect, and leave in an undamaged condition.
- D. At completion of construction activities of other trades, touch up and restore damaged or defaced painted surfaces.

3.5 EXTERIOR PAINTING SCHEDULE

- A. Concrete Substrates, Steel Substrates:
 - 1. Acrylic System :
 - a. Prime Coat: Primer, alkali resistant, water based.
 - b. Topcoat: Latex, exterior, semi-gloss (MPI Gloss Level 5).

END OF SECTION 099113

SECTION 31 10 00 - SITE CLEARING

PART 1 GENERAL

1.1 SECTION INCLUDES

- A. This section covers all those measures required during the Contractor's initial move onto the site to protect existing fences, facilities, and associated improvements, and utilities adjacent to the construction areas from damage due to boulders, trees or other objects dislodged during the construction process; clearing, grubbing and stripping.

1.2 RELATED SECTIONS

- A. The following is a list of Specifications which may be related to this section:
 - 1. Section 31 20 00 - Earth Moving
 - 2. New York City Building Code (NYCBC), Latest Edition
 - 3. New York City Department of Transportation (NYCDOT)
 - 4. Manual of Uniform Traffic Control Devices (MUTCD), recent edition
 - 5. New York State Department of Transportation (NYSDOT)
 - 6. OSHA Safety and Health Standards for Construction 29 CFR 1926

1.3 REFERENCE

- A. The Geotechnical Engineering Report.

1.4 ACTUAL SITE CONDITIONS

- A. The Contractor shall determine the actual condition of the site as it affects this portion of the Work.
- B. Site preparation shall not damage existing structures or cause obstruction and/or contamination to the property. The Contractor shall repair or replace any damaged property at no cost to the BPCA.
- C. While work is being performed, the Contractor shall provide adequate access to all operating equipment for routine operation and maintenance. The Contractor shall erect and maintain fences, warning signs, barricades, and other devices as required for the protection of the Contractor's employees and the BPCA's personnel at the job site. The Contractor shall remove all such protection when the earthwork operations are completed, or as directed by the Engineer.

1.5 SUBMITTALS

- A. Submittals for items specified herein shall be submitted by the Contractor and shall be in accordance with the Contract Documents.

- B. A copy of this specification section, with any addendum updates included, and all referenced and applicable sections, with any addendum updates included, shall be submitted with each paragraph check-marked to indicate specification compliance or marked to indicate requested deviations from specification requirements. Check marks (☐) shall denote full compliance with a paragraph as a whole. If deviations from the specifications are indicated, and therefore requested by the Contractor, each deviation shall be underlined and denoted by a number in the margin to the right of the identified paragraph. The remaining portions of the paragraph not underlined will signify compliance on the part of the Contractor with the specifications. The submittal shall be accompanied by a detailed, written justification for each deviation. Failure to include a copy of the marked-up specification sections, along with justification(s) for any requested deviations to the specification requirements, with the submittal shall be sufficient cause for rejection of the entire submittal with no further consideration.
- C. Submittals shall be provided to confirm that materials to be used comply with information specified herein.
- D. The Contractor shall submit to the Engineer a schedule of proposed disposal locations and written authorization from disposal site owner.
- E. The Contractor shall submit Work Plans and Safety Measure Drawings.
- F. The Contractor shall submit a pre-construction survey of the area of work including existing topography, above grade structures, and below grade structures and utilities within the area of work.

1.6 FIELD CONDITIONS

- A. Traffic: Minimize interference with adjoining roads, streets, walks, and other adjacent occupied or used facilities during site-clearing operations.
 - 1. Do not close or obstruct streets, walks, or other adjacent occupied or used facilities without permission from Owner and authorities having jurisdiction.
 - 2. Provide alternate routes around closed or obstructed trafficways if required by Owner or authorities having jurisdiction.
 - 3. Provide a Maintenance and Protection of Traffic Plan (MPT) in accordance with the latest NYC and NYS DOT standards for work in the right-of-way.
- B. Improvements on Adjoining Property: Authority for performing site clearing indicated on property adjoining Owner's property will be obtained by Owner before award of Contract.
 - 1. Do not proceed with work on adjoining property until directed by the Engineer.

- C. Salvageable Improvements: Carefully remove items indicated to be salvaged and store on Owner's premises as directed by the Owner.
- D. Utility Locator Service: Notify utility locator service Dig Safe System and One Call for area where Project is located before site clearing.
- E. Do not commence site clearing operations until temporary erosion- and sedimentation-control and tree-protection measures are in place.
- F. Tree- and Plant-Protection Zones: Protect according to requirements on the contract drawings and in Section 015639 "Temporary Tree and Plant Protection."

PART 2 PRODUCTS

2.1 SAFETY BARRIERS

- A. The proximity of the Work to the Right-of-Way (ROW) and existing structures will require construction of appropriate safety barriers such as temporary fencing, berms, or similar facilities.
- B. To minimize disturbance to pedestrians and/or vehicular traffic, safety barriers or fencing shall allow for operation of construction equipment and staging of materials associated with this Work.
- C. The Contractor shall prepare a submittal to the Engineer with Contract Drawings that define the proposed safety measures prior to any construction activity.
- D. All work shall be performed in conformance with the rules and regulations pertaining to safety as established by NYCDOT and OSHA.

PART 3 EXECUTION

3.1 CLEARING, GRUBBING, AND STRIPPING

- A. Where existing utilities interfere with the Work, the Work shall be stopped, and the Engineer and BPCA shall be notified of interferences before restarting the work in accordance with the Contract Documents.
- B. All construction areas shall be cleared of structures, concrete or masonry debris, landscaping, trees, logs, upturned stumps, grass, weeds, loose boulders, and any other objectionable material of any kind which would interfere with the performance or completion of the Work, create a hazard to safety, or impair the Work's subsequent usefulness or obstruct its operation.
- C. Loose boulders within 10 feet of the top of cut lines shall be incorporated in landscaping or removed from the site. Trees and other natural vegetation

outside the actual lines of construction shall be protected from damage during construction.

- a. Within the limits of clearing, the areas below the natural ground surface shall be grubbed to a depth necessary to remove all stumps, roots, buried logs, and all other objectionable material.
- D. Cleanouts and connection lines and any other underground structures, debris or waste shall be totally removed if they are found on the site. All objectionable material from the clearing and grubbing process shall be removed and disposed of according to the governing regulations.
- E. Additional requirements for excavating or removing existing facilities and soil are shown on the Contract Drawings.
- F. Unless otherwise shown or specified, native trees larger than three inches in diameter at the base shall not be removed without the Engineer's approval.
- G. The removal of any trees, shrubs, fences, or other improvements outside of the limits of construction as deemed necessary by the Contractor, shall be arranged and authorized by BPCA.
- H. Trees and shrubbery adjacent to the trench, pole lines, fences, signs, survey markers and monuments, buildings and structures, conduits, pipeline under or above ground, all roadway facilities and any other improvements or facilities within or adjacent to the work shall be protected from injury or damage, and, if ordered by the Engineer, the Contractor shall provide and install suitable safeguards approved by the Engineer to protect such objects from injury or damage.
- I. Serious injuries to trees to remain shall be avoided. No major roots or branches crossing the trench shall be cut if such cutting would seriously injure or imperil the safety of the tree or trench. All limbs, roots or branches, which are cut or broken, shall be trimmed and painted with an approved tree seal. If other objects are injured or damaged by reason of the Contractor's operations, they shall be replaced or restored, at the Contractor's expense, to the condition at the time the Contractor entered upon the work.
- J. The Engineer shall be notified when site preparation work is completed.

3.2 REGRADING AND SUBGRADE PREPARATION

- A. In areas to receive fill, the stripped surface should be scarified to a depth of about 6 inches below the excavated level, conditioned to near optimum moisture content and proof-rolled to the inspection and satisfaction of the Engineer.

- B. Any holes remaining after stripping and grubbing shall be backfilled unless they are located within an area designated for further excavation or over-excavation and replacement.
- C. Subgrade preparation, backfill material and placement shall be in accordance with Section 31 20 00 - Earth Moving.

3.3 DISPOSAL OF DEBRIS

- A. Dispose of removed materials, waste, trash, and debris in a safe, acceptable manner, in accordance with applicable laws and ordinances and as prescribed by authorities having jurisdiction.
- B. Burying of trash and debris on the site will not be permitted.
- C. Burning of trash and debris at the site will not be permitted.
- D. Remove trash and debris from the site daily so that its presence will not delay the progress of the Work.
- E. Removed materials, trash, and debris shall become the property of the Contractor and shall be removed from the BPCA's property and disposed of in a legal manner. Location of disposal site and length of haul shall be the Contractor's responsibility.

3.4 UTILITY INTERFERENCE

- A. If an existing utility is not indicated on the Contract Drawings but is encountered during the Work, the Contractor shall notify the Engineer and BPCA for further direction.
- B. The determination to relocate or reroute conflicting utilities will originate from BPCA and will be reported to the utility owners for acknowledgement and permission.

3.5 RELOCATION AND REPLACEMENT

- A. Where existing above-ground items and structures interfere with the Work and require relocation and/or replacement, the Contractor shall replace or relocate the items to as close as their original condition.

END OF SECTION 310000

THIS PAGE INTENTIONALLY LEFT BLANK

SECTION 311500 - EXCAVATION SUPPORT AND PROTECTION

PART 1 - GENERAL

1.1 THE REQUIREMENT

- A. The Work specified in this Section includes shoring systems for the support of excavations including, but not limited to, trench and structure excavations. The Contractor shall design, furnish, install, and remove upon completion of the required construction, unless shown otherwise, all systems of supports, including all bracing and associated items to retain the sides of the excavations. The Contractor shall be responsible for the selection of methods, the design, construction and removal of all shoring systems. Shoring shall be required.
- B. Design of ground support system and methods should be the sole responsibility of the Contractor. The Contractor's ground support plan must take into consideration the subsurface conditions at the site. The Contractor should independently evaluate ground support systems and make his own selection of appropriate ground support techniques which meet the project requirements. The ground support and dewatering system are interdependent and, as such, the ground support and dewatering systems shall be submitted by the Contractor at the same time for review.
- C. The provisions specified hereunder shall be understood:
 - 1. To complement, and not to substitute or diminish, the obligations of the Contractor for the furnishing of a safe place of work pursuant to the provisions of the Occupational Safety and Health Act of 1970 and its subsequent amendments and regulations and for the protection of the Work, structures, and other improvements.
 - 2. To represent a minimum requirement:
 - a. For the number and types of means needed to maintain soil stability,
 - b. For the strength of such required means, and
 - c. For the methods and frequency of maintenance and observation of the means used for maintaining soil stability.
- D. Excavation support shall include sheeting, shoring, bracing, and other means and procedures required to maintain the stability of soils
- E. Excavation supports shall be provided:
 - 1. Where, as a result of excavation work and an analysis performed pursuant to general Engineering design practice,
 - a. The excavated face or surrounding soil mass may be subject to slides, caving, or other type of failure, or

- b. The stability and integrity of structures and other improvements may be compromised by settlement or shifting of soils.
 2. For trench and pit (shaft) walls as required per New York OSHA.
 3. As required per New York OSHA Construction Safety Orders, Article 6 and OSHA 29 CFR 1926 (Occupational Safety and Health Standards- Excavation; Final Rule).
- F. The Contractor shall obtain any necessary permits from the New York City, Division of Industrial Safety. The Contractor shall pay all costs in connection with said permits and proof of such permits shall be submitted to the Engineer prior to commencing trench work.
- G. Trench shoring and bracing shall conform to provisions in Section 5-1.02A, "Trench Excavation Safety Plans", of the New York Standard Specifications and to the specification herein. If a conflict exists between the New York Standard Specifications and specifications herein, the more stringent shall apply.
- H. Related to "Sheeting, Shoring, and Bracing":
1. In accordance with the provisions of the governing body and BPCA
 2. Each bidder shall list, in the bid item indicated, the amount included in his/her bid for trench and excavation, adequate sheeting, shoring and bracing, or equivalent method for the protection of life and limb, work that shall conform to applicable New York City Construction Safety Orders. By listing this sum in his/her bid, the bidder warrants that his/her action does not convey tort liability to the BPCA, the BPCA's officials or employees, the Design Engineer, or the Contractor.
- I. Related to " Bidder Responsibility":
1. Carefully study all reports of explorations and tests of subsurface conditions at or contiguous to the Site and all drawings of physical conditions in or relating to existing surface or subsurface structures at or contiguous to the Site that have been identified and carefully study all reports and drawings of a Hazardous Environmental Condition, if any, at the Site, that may have been identified.
 2. Provide, obtain, and carefully study (or assume responsibility for doing so) all additional, independent, or supplementary examinations, investigations, explorations, tests, studies, and data concerning conditions (surface, subsurface, and underground facilities) at or contiguous to the Site that may affect cost, progress, or performance of the Work or that relate to any aspect of the means, methods, techniques, sequences, and procedures of construction expressly required by the Project Manual and safety precautions and programs incident thereto.
 3. Retain and use the services of one or more registered professional Engineers with expertise in geotechnical Engineering for analyzing the "technical data" contained in the geotechnical report and making recommendations related to means, methods, techniques, sequences, and procedures of construction that may be affected by job site soils conditions. Such means and methods shall include, but shall not be limited to: control of groundwater,

surface water, and excavation drainage, excavation, sheeting, shoring, bracing, backfill, compaction, construction equipment, temporary construction facilities, and other construction-related procedures.

4. Agree at the time of submitting its Bid that no further examinations, investigations, explorations, test, studies, or data are necessary for the determination of its Bid for performance of the Work at the price bid and within the times and in accordance with the other terms and conditions of the Project manual.

J. Related Sections

1. Division 31 Section 312319 - Dewatering
2. Division 31 Section 312000 - Earth Moving

1.2 STANDARDS AND REGULATIONS

Except as modified by the governing codes and by the Contract Documents, comply with the applicable provisions and recommendations of the following:

- A. Occupational Safety and Health Administrative Code.
- B. Manual of Steel Construction, AISC, 9th Edition.
- C. American Society of Testing and Materials (ASTM) standards, latest editions.
- D. The Contractor's attention is directed to the provisions for "Shoring and Bracing Drawings"
- E. The Contractor, prior to beginning any trench, pit, or structure excavation, shall submit to the Engineer and shall be in receipt of the Engineer's written acceptance of the Contractor's detailed plan showing design of all shoring, bracing, sloping of the sides of excavation, or other provisions for worker protection against the hazard of caving ground during the excavation of such trenches or structure excavation.
- F. Plans shall be prepared and sealed by a Civil or Structural Engineer registered in the City of New York.

1.3 DESIGN CRITERIA

- A. In all areas, the shoring system, including all the components, shall be designed by the Contractor to support earth pressure (saturated and unstaturated), hydrostatic pressures, utility loads, equipment, applicable traffic and construction loads, and other surcharge loads in such manner as will allow the safe and expeditious construction of the permanent facilities without movement or settlement of the ground and will prevent damage to or movement of adjacent structures and utilities.
- B. Shoring systems shall meet the following minimum performance requirements and design criteria.

1. Comply with all governing regulations pertaining to excavation safety (e.g., the most current edition of New York/OSHA construction safety orders, article 6).
2. Be compatible with the surface and subsurface soil and groundwater conditions mapped and encountered and resist lateral earth pressures and hydrostatic pressures (where not dewatered).
3. Protect personnel that enter the excavation.
4. Protect existing utilities, pavements, and structures.
5. Installation of the shoring system must occur in a manner and sequence that does not damage existing structures, pavements, and utilities including through settlement, heave or vibrations.
6. Prevent caving (i.e., raveling, running, or flowing) or lateral movement of excavation walls and associated loss of adjacent ground and adjacent ground surface settlement, even when subjected to construction vibrations.
7. Provide stable excavation walls and bottom (e.g., prevent bottom heave).
8. As permitted by the specifications, allow for removal or abandonment of shoring in a manner and sequence that (1) is in step with the backfilling sequence (i.e., shoring should not be removed ahead of backfilling) and (2) does not damage the finished utility line or structures or existing structures, pavements, and utilities including through settlement, heave or vibrations.
9. Resist lateral earth pressures including those from hydrostatic pressures and lateral loads from vehicular traffic, construction equipment and spoils.
10. Allow construction of thrust blocks in jacking shafts adequate to resist anticipated jacking forces with appropriate safety factors.
11. Special shoring and/or ground improvement, including grout stabilization may be required and designs shall be provided by the Contractor, where excavations are in close proximity to structures, utilities, or unlined drainage to minimize potential excavation-related damage. Special shoring and/or ground improvement designs shall be required where excavations are:
 - a. Within an imaginary plane protected downward at an inclination of 2H:1V from the nearest foundation edge or utility line.
 - b. Below the depth of flow within adjacent unlined drainageways.
 - c. Experiencing flowing, running and/or raveling ground conditions (i.e., soils with little to no stability or support).
12. The Contractor shall design each member to support the maximum loads that can occur during construction. For the purpose of this Section, the design load means the maximum load the support member of the shoring system will have to carry in actual practice.
13. The submittals shall provide Contractor's Shop Drawings and design calculations for each stage of the excavation including installation and removal of the shoring system. The Contractor shall submit all design assumptions and design criteria, as well as references for the design criteria and assumptions used. The strut preloading procedure, including information on the jacking system and calibration data for the hydraulic jacks, shall also be submitted for review.

14. The Contractor shall design the bottom of the support system to be carried to a depth below the main excavation adequate to prevent excessive bottom heave, lateral and vertical movements, and ensure stability of the excavation.
 15. Review of the Contractor's plans and methods of construction shall not relieve the Contractor of the sole responsibility of providing an adequate support system to support all load configurations encountered to complete the required work.
 16. The struts shall be preloaded to 50 percent of the design load. Preloading shall be accomplished by jacking between the struts and wales. Provisions shall be made for permanently fixing each member, after preloading, with steel shims or wedges welded in place. Wood wedges shall not be allowed.
 17. The sequence of excavation, installation, and removal of the shoring and preloading of the struts shall be carried out in a manner that lateral movement and settlement of the soil surrounding the excavations is minimized.
 18. The vertical spacing of the struts shall not exceed 10 ft.
- C. It is the Contractor's responsibility to review the existing underground utilities to make his own interpretation regarding the ground conditions as described in the referenced report, and to make any other additional surveys and/or borings he believes are necessary to determine the types and extent of bracing and shoring systems required to accomplish the Work. All of the foregoing costs shall be included in the Contractor's total price for performing the Work.
- D. Sloped excavations shall not be permitted, unless otherwise approved by the Engineer.

1.4 CONTRACTOR SUBMITTALS

- A. Submittals for items herein shall be submitted by the Contractor and shall be in accordance with the Contract Documents.
- B. A copy of this specification section, with any addendum updates included, and all referenced and applicable sections, with any addendum updates included, shall be submitted with each paragraph check-marked to indicate specification compliance or marked to indicate requested deviations from specification requirements. Check marks (✓) shall denote full compliance with a paragraph as a whole. If deviations from the specifications are indicated, and therefore requested by the Contractor, each deviation shall be underlined and denoted by a number in the margin to the right of the identified paragraph.
- C. The remaining portions of the paragraph not underlined will signify compliance on the part of the Contractor with the specifications. The submittal shall be accompanied by a detailed, written justification for each deviation. Failure to include a copy of the marked-up specification sections, along with justification(s) for any requested deviations to the specification requirements, with the submittal shall be sufficient cause for rejection of the entire submittal with no further consideration.
- D. Submittals shall be provided to confirm that material to be used comply with information specified herein.

- E. Contractor's Shop Drawings. The Contractor shall submit Contractor's Shop Drawings of temporary excavation support systems. The Contractor's Shop Drawings shall be prepared and sealed by a Civil or Structural Engineer registered in the New York City.
1. The Contractor, prior to beginning any trench or structure excavation more than 5 ft deep shall submit to the Engineer a detailed plan showing design of all shoring and bracing of the sides of excavation, or other provisions for worker protection against the hazard of caving ground during the excavation of such trenches or structure excavation. The Contractor's attention is directed to the provisions for "Shoring and Bracing Drawings" in Section 6705 of the New York Labor Code. Plans shall be prepared by a Civil or Structural Engineer licensed in the New York City.
 2. The Contractor shall prepare and submit drawings and supporting calculations showing proposed shoring systems. The submittals shall include details, arrangement, and method of construction for the proposed shoring systems including levels of struts and shores, as applicable and permissible depth to which excavation may be carried before such supports are installed. Show full excavation depth load to be carried by various members of the support system, and, if required, the preloads. Design calculations shall include design surcharge loads and calculated deflections of shoring and support members. Drawings and calculations shall be prepared by a Civil or Structural Engineer licensed in the New York City.
 3. The Contractor shall submit proposed method of installing shoring including the sequence of driving, template, and driving equipment description. The proposed construction sequence including strut placement and strut and shore removal as related to excavation, construction, and backfilling operations shall be shown.
- F. All expenses incurred in performing the Work described in this Section shall be borne by the Contractor.

1.5 JOB CONDITIONS

- A. Provision for Contingencies:
1. The Contractor shall provide contingency plans or alternative procedures to be implemented if unfavorable shoring system performance is evidenced.
 2. The Contractor shall keep on hand materials and equipment necessary to implement contingency plan or alternate procedures
- B. The Contractor shall proceed with caution in areas where utilities are within the shoring and excavation prism. Such utilities shall be exposed by hand excavation or other methods acceptable to the BPCA.
- C. If existing utilities interfere with proposed method of support, the Contractor shall modify the support system at his own expense.

1.6 TOLERANCE

- A. Location of the necessary shoring shall be within 3 inches of that shown on the Contractor's Shop Drawings.
- B. In the areas adjacent to existing facilities, the excavation shoring system shall deflect vertically and/or horizontally no more than 1 inch from its original position.

1.7 RELATED REPORTS

Geotechnical Engineering Report of this project.

PART 2 - PRODUCTS

2.1 MATERIALS

- A. All timber and structural steel used for the supporting system, whether new or used, shall be sound and free from defects that may impair their strength.
- B. If used, sheet piling shall be of a continuous interlocking type forming a continuous wall. Sheet piling and all accessories shall conform to the requirements of ASTM A328.
- C. Trench boxes can also be used in lieu of sheet piling and will need to be installed per manufacturer's specifications .
- D. Structural steel members shall be designed in accordance with the Manual of Steel Construction. Timber members shall be designed in accordance with the Uniform Building Code.

PART 3 - EXECUTION

3.1 STEEL SHEET PILING (IF USED)

- A. The Contractor shall drive sheet piling in plumb position with each pile interlocked with adjoining piles for its entire length so as to form a continuous diaphragm throughout the length of each run of wall, bearing tightly against original ground.
- B. The Contractor shall exercise care in driving to avoid damage to existing utilities so that interlocking members can subsequently be extracted without injury to adjacent fills or existing utilities.
- C. The methods of driving, cutting, and splicing shall conform to the Contractor's Shop Drawings.
- D. The Contractor shall maintain a sufficient quantity of material on hand for sheeting, shoring, bracing, and other operations for protection of work and for use in case of emergency.
- E. Sheet pile driving shall be restricted to the hours between 8:00 a.m. and 5:00 p.m.

3.2 INTERNAL BRACING SUPPORT SYSTEM

- A. The Contractor shall provide internal bracing support system including lagging and sheeting, sheet piles, wales, struts, and/or shores.
 - 1. All struts with intermediate bracing shall be provided as needed to enable them to carry maximum design load without distortion or buckling.
 - 2. All web stiffeners, plates, or angles shall be provided as needed to prevent rotation, crippling, or buckling of connections and points of bearing between structural steel members that allow for eccentricities caused by field fabrication and assembly.
- B. The Contractor shall install and maintain all bracing support members in tight contact with each other and with the surface being supported. Support system monitoring provisions shall be installed as indicated on the approved Contractor's Shop Drawings.
- C. If necessary to control shoring movement, the Contractor shall preload bracing members by jacking struts to 50 percent of the design load. Preload bracing members shall be loaded in accordance with methods, procedures, and sequence as described on the approved Contractor's Shop Drawings. Excavation work shall be coordinated with the installation of bracing and preloading. Steel shims and steel wedges welded or bolted in place to maintain the preloading force shall be used in the bracing after release of the jacking equipment pressure.
 - 1. Procedures that produce uniform loading of bracing members to avoid eccentricities or overstressing and distortion of members of wall system shall be used.
 - 2. Preloading systems shall include a method to measure the amount of preload induced into bracing members to within 5 percent.
- D. Excavation shall proceed to no more than 2 ft below the point of the support about to be placed. The support shall be installed and preloaded immediately after installation and prior to continuing excavation.

3.3 REMOVAL OF SUPPORTING SYSTEM

- A. The Contractor shall remove all shoring, including sheet piles, wales, struts, lagging and shores from the excavation unless indicated otherwise on the Drawings. Removal of the supporting system shall be performed in a manner that will avoid damage of adjacent construction or facilities. All voids created by the removal of the supporting system shall be immediately filled with well-graded cohesionless sand, lean concrete or sand cement grout.

3.4 ORTECT EXISTING UTILITIES

- A. Contractor shall shore and protect existing utilities when working on or adjacent to such utilities.

3.5 INSTALLATION

- A. Excavation support shall be installed as indicated in the approved submittals.
- B. Excavations, including trenching, shall not begin until the excavation support submittals have been accepted and until the materials necessary for the installation are on site.

END OF SECTION 311500

THIS PAGE INTENTIONALLY LEFT BLANK

SECTION 31 20 00 - EARTH MOVING

PART 1 GENERAL

1.1 SECTION INCLUDES

- A. This Section covers all earthwork required for construction of the new Flood Wall. Such earthwork shall include, but not be limited to the loosening, removing, loading, transporting, depositing, and compacting in its final location of all materials wet and dry, as required for the purposes of completing the new Flood Wall specified in the Contract Documents and/or Contract Drawings (including Contract Drawings). The new Flood Wall shall also include the supporting of structures (such as fencing) and utilities (such as drainage and corrosion protection utilities, where warranted) above and below the ground, all backfilling around structures and utilities and all backfilling of trenches and pits, the disposal of excess excavated materials, borrow of materials to make up deficiencies of fill/s, and all other incidental earth works, all in accordance with the requirements of the Contract Documents and/or Contract Drawings.

1.2 RELATED SECTIONS

- A. The following is a list of Specifications which may be related to this Section:
1. Section 31 10 00 - Site Clearing
 2. Section 31 50 00 - Excavation Support and Protection
 3. Section 31 23 19 - Dewatering
 4. Section 03 30 00 - Cast-in-Place Concrete

1.3 REFERENCE

- A. Geotechnical Engineering Report and Supplemental Memorandum Reports
- B. The following is a list of standards which may be referenced in this Section:
1. New York City Building Code (NYCBC), Latest Edition
 2. New York City Department of Transportation (NYCDOT)
 3. New York State Department of Transportation (NYSDOT)
 4. OSHA Safety and Health Standards for Construction 29 CFR 1926
 5. Manual of Uniform Traffic Control Devices (MUTCD), recent edition

6. United States Army Corps of Engineers (USACE) Specifications and Design Manuals:
 - a. EM 1110-2-2104, Strength Design for Reinforced Concrete Hydraulic Structures
 - b. EM 1110-2-2105, Design of Hydraulic Steel Structures
 - c. EM 1110-2-2502, Retaining and Flood Walls
 - d. EM 1110-2-2705, Structural Design of Closure Structures for Local Flood
 - e. EM 1110-2-1901, Seepage Analysis and Control for Dams
 - f. EM 1110-2-2100, Stability Analysis of Concrete Hydraulic Structures

7. American Society for Testing and Materials International (ASTM):
 - a. C330, Standard Specification for Lightweight Aggregates for Structural Concrete
 - b. D1556, Standard Test Method for Density and Unit Weight of Soil in Place by the Sand-Cone Method.
 - c. D1557, Standard Test Methods for Laboratory Compaction Characteristics of Soil Using Modified Effort (56,000 ft-lbf/ft³ or 2,700 kN-m/m³).
 - d. D2419, Standard Test Method for Sand Equivalent Value of Soils and Fine Aggregate.
 - e. D2487, Standard Practice for Classification of Soils for Engineering Purposes (Unified Soil Classification System).
 - f. D2844, Standard Test Method for Resistance R-Value and Expansion Pressure of Compacted Soils.
 - g. D3744, Standard Test Method for Aggregate Durability Index.
 - h. D4253, Standard Test Methods for Maximum Index Density and Unit Weight of Soils Using a Vibratory Table.
 - i. D4254, Standard Test Methods for Minimum Index Density and Unit Weight of Soils and Calculation of Relative Density.
 - j. D4355, Standard Test Method for Deterioration of Geotextiles by Exposure to Light, Moisture and Heat in a Xenon-Arc Type Apparatus.
 - k. D4491, Standard Test Methods for Water Permeability of Geotextiles by Permittivity.
 - l. D4632, Standard Test Method for Grab Breaking Load and Elongation of Geotextiles.
 - m. D4751, Standard Test Method for Determining Apparent Opening Size of a Geotextile.
 - n. D4833, Standard Test Method for Index Puncture Resistance of Geomembranes and Related Products.

- o. D5261, Standard Test Method for Measuring Mass Per Unit Area of Geotextiles.
- p. D4533, Standard Test Method for Trapezoid Tearing Strength of Geotextiles.
- q. D6938, Standard Test Methods for In-Place Density and Water Content of Soil and Soil-Aggregate by Nuclear Methods (Shallow Depth).

1.4 QUALITY ASSURANCE

- A. The Contractor shall accomplish the specified compaction for backfill or other earthwork. Compaction testing will be provided by the BPCA or General Contractor at a testing laboratory of the BPCA or General Contractor's choice.
- B. Where soil material is required to be compacted to a percentage of maximum density, the maximum density at optimum moisture content shall be determined in accordance with ASTM D1557.
- C. Where cohesionless, free draining soil material is required to be compacted to a percentage of relative density, the calculation of relative density shall be determined in accordance with ASTM D4253 and ASTM D4254.
- D. Particle size analysis of soils and aggregates shall be performed using ASTM D422.
- E. Determination of sand equivalent value shall be performed using ASTM D2419.
- F. The determination of aggregate durability index shall be made using ASTM D3744.
- G. Existing asphalt or concrete cannot be buried.
- H. No recycled materials shall be used.
- I. Asphalt cannot be reused as fill.
- J. Materials used within the NYS and NYC DOT right of way as base and subbase materials for pavement shall follow the latest specifications and standards of the governing agency.

1.5 QUALITY CONTROL

- A. Field density in-place tests (special inspections) shall be performed in accordance with ASTM D1556, ASTM D6938, or by such other means acceptable to the Engineer. It is the responsibility of the Contractor to accomplish the specified compaction for earthwork.

- B. The Contractor shall give the Engineer a minimum 24 hours' notice before requiring compaction testing services in the field. The Contractor will be charged for the cost of all re-tests where the tests do not meet the requirements of the Specifications.
- C. In case the tests of the fill or backfill show non-compliance with the required density in the field, the Contractor shall accomplish such remedy as may be required to insure compliance. Subsequent testing to show compliance shall be by a testing laboratory selected by the BPCA or General Contractor and shall be at the Contractor's expense.

1.6 SUBMITTALS

- A. Submittals for all material, and equipment items specified herein shall be submitted by the Contractor and shall be in accordance with the Contract Documents and/or Contract Drawings: The following is a list of material and work and shall by no means be exhaustive:
 - 1. Geotechnical laboratory results of onsite subsurface soils, such as gradation analysis, compaction (modified proctor) at maximum dry density and optimum moisture, etc.
 - 2. Mill certificate and geotechnical laboratory results of all imported fill/structural fill.
 - 3. Specifications for soil excavating and compaction equipment (including gross vehicle weight).
 - 4. Signed and sealed flowable fill mix design.
- B. A copy of this Specification Section, with any addendum updates included, and all referenced and applicable Sections, with any addendum updates included, shall be submitted with each paragraph check-marked to indicate Specification compliance or marked to indicate requested deviations from Specification requirements. Check marks (✓) shall denote full compliance with a paragraph as a whole.
- C. If deviations from the Specifications are indicated, and therefore requested by the Contractor, each deviation shall be underlined and denoted by a number in the margin to the right of the identified paragraph. The remaining portions of the paragraph not underlined will signify compliance on the part of the Contractor with the Specifications.
- D. The submittal shall be accompanied by a detailed, written justification for each deviation. Failure to include a copy of the marked-up Specification Sections, along with justification(s) for any requested deviations to the Specification requirements, with the submittal shall be sufficient cause for rejection of the entire submittal with no further consideration.
- E. Submittals shall be provided to confirm that materials to be used are in full compliance with information specified herein.

- F. The Contractor shall submit to the Engineer a schedule of proposed disposal locations and written authorization from disposal site owner, where soils and fill material are planned to be disposed of.
- G. The Contractor shall submit their work safety plans (including means and methods), work safety measures drawings and other diagrammatic safety protocols pertaining to this work.
- H. The Contractor shall submit equipment and material (such as fill) staging plans, including notes on work sequencing.

PART 2 PRODUCTS

2.1 SUITABLE MATERIALS GENERAL

A. Aggregate Base

- 1. Where applicable, Aggregate Base may be used to form a stable base of roadways and structures where needed.
- 2. Aggregate Base shall conform to the following gradation requirements:

Aggregate Base	
Sieve Size	Percent Passing
1-inch	100
¾-inch	90-100
No. 4	35 - 60
No. 30	10 - 30
No. 200	2- 9

- 3. Aggregate Base shall be hard, sound and durable gravel or crushed rock, which shall not slake or disintegrate in water. Recycled materials are not acceptable. It shall be free from vegetative or other organic matter and other deleterious substances and form a firm, stable base when compacted.

B. Coarse Bedding Material

- 1. Coarsely graded bedding material may be used as bedding material for foundations and other underground structures where drainage is considered.
- 2. Coarse bedding material should be clean, durable, crushed (i.e., angular) aggregate rock conforming to the following gradation requirements:

Coarse Bedding Material	
Sieve Size	Percent Passing
2-inch	100

Coarse Bedding Material	
Sieve Size	Percent Passing
1 ½-inch	95-100
¾-inch	5-30
⅜-inch	5-20
No. 200	0-4

C. Drain Rock

1. Drain Rock may be used for temporary path/roadways for heavy equipment.
2. Drain rock shall be ½-inch diameter crushed rock or gravel, durable and free from slaking or decomposition under the action of alternate wetting or drying. The material shall be uniformly graded and shall meet the following gradation requirements:

3.

Drain Rock	
Sieve Size	Percent Passing
1-inch	100
¾-inch	90-100
⅜-inch	40-100
No. 4	25-40
No. 8	18-33
No. 30	5-15
No. 50	0-7
No. 200	0-3

D. Gravel

1. Gravel shall refer to ½- or ¾-inch diameter clean crushed rock or gravel, durable and free from slaking or decomposition under the action of alternate wetting or drying.
2. The material shall be uniform in size and angular in shape.
3. Gravel may be used in conjunction with geotextiles to allow a less-thick placement for over excavations.

E. Flowable Fill

1. Flowable Fill (controlled low strength material) may be used to fill in voids encountered during excavation.

2. Flowable Fill mix shall be composed of a cementitious material, water, fine aggregate and an admixture. The cementitious material shall be Portland cement in combination with fly ash (if authorized by NYCDEP). The admixture shall be an air-entraining agent.
3. The proportions of all material used in the flowable fill shall conform to the specific mix design as intended by the Engineer.
4. Flowable Fill shall have an unconfined compressive 28-day strength from 50 psi (hand excavatability) to a maximum of 100 psi (backhoe excavatability).
5. The wet unit weight of the flowable fill shall be no greater than 100 pounds per cubic foot (pcf); the cured unit weight shall be no greater than 120 pcf
6. Consistency of the flowable fill shall be flowable and self-leveling, with slump from 6 to 10 inches.
7. Any aggregates which produce performance characteristics of the flowable fill may be submitted for approval. Flowable Fill mixture shall contain no aggregate that is larger than $\frac{3}{8}$ -inch.
8. The amount of material passing the No. 200 sieve shall not exceed 12 percent; no plastic fines shall be present.
9. The air content by volume based on measurement made immediately after discharge from the mixer shall be determined by ASTM C231 as is based on the specified cured unit weight.
10. Provide the Engineer with delivery tickets for each truck load that shows the flowable fill mix, the batch size and the time batched.
 - a. Cement shall conform to ASTM C150, Type II.
 - b. At NYCDEP's direction, concrete that is in contact with potable water shall not contain recycled content (fly ash) due to potential leaching issues shall conform to ASTM C618, Class F.
 - c. If authorized by NYCDEP, fly ash and other pozzolanic material admixtures may be added at a rate not to exceed 30 lb per 94 lb of cement. The admixture shall conform to ASTM C618:
 - i. Fly ash shall not inhibit the entrainment of air during application.
 - ii. Fly ash shall not leach into the groundwater.
 - d. Air entraining admixture shall conform to ASTM C260.
11. Flowable Fill shall be batched by a ready mixed concrete plant and mixed and delivered to the jobsite by means of transit mixing trucks.
12. Field testing of flowable fill shall be as specified for concrete based on ACI standards and the Contract Drawings.
13. No equipment or traffic shall be allowed on the flowable fill until the surface of the flowable fill will withstand the weight of equipment or traffic without displacement or damage. If necessary to prevent displacement or damage,

provide steel trench plates that span the trench or other means that prevent equipment or traffic contact with flowable fill.

F. Lightweight Fill

1. Lightweight fill shall conform to ASTM Designation C330 Standard Specification for Lightweight Aggregates for Structural Concrete.
2. Lightweight aggregate shall have a proven record of durability and non-corrosive with the following properties:
 - a. The gradation should conform to the ASTM C330 Size Designation Coarse Aggregate, which is as follows:

Sieve Size	Percent Passing
1-inch	100
3/4-inch	80-100
3/8-inch	10-50
No. 4	0-15
No. 100	0-5

- b. The dry, loose unit weight shall be less than 55 pcf. The Contractor shall verify a compacted density of less than 60 pcf, as measured in accordance with ASTM D-698 (the standard test methods of moisture-density relations of solid and aggregate mixtures using a 5.5 lb. hammer and 12-inch drop).
3. Lightweight fill shall be placed in layers not exceeding twelve (12) inches, measured prior to compaction. Lightweight fill behind the Flood Wall, where warranted, shall be compacted according to the manufacturer's Specification and shall not induce excessive stresses to the new Flood Wall.
4. Construction equipment, other than for compaction, shall not operate on the exposed lightweight fill.
5. The areas to be backfilled shall not have any standing water in it prior to placement of the lightweight fill.
6. Lightweight fill shall not be placed when frozen or on frozen material.
7. Lightweight fill shall have a pH between 6.5 and shall conform to ASTM C88 for soundness and durability.

G. Sand

1. Sand shall be free of organics and other deleterious materials.
2. Sand should be chemically inert and non-corrosive.
3. Sand may be backfilled as utility bedding or for purposes of leveling or setting.

4. Sand shall meet the following gradation requirements:

Sieve Size	Percent Passing
No. 4	95-100
No. 200	0-5

F. Native Material

1. Native Material may be reused if it meets the requirements below and only where native material is indicated for use on the Contract Documents and/or Contract Drawings:
 - a. Native soil below the stripped layer (topsoil or fill) and having an organic content of less than 3 percent by volume.
 - b. Native soil that does not contain rocks or lumps larger than 6 inches in greatest dimension with not more than 15 percent larger than 2.5 inches.
 - c. Native soil shall be considered unsuitable material as outlined below.
 - 1) Unsuitable soils for fill material shall include, but not be limited to, all soils which when classified under ASTM D2487 fall in the classification of PT, OH, CH, MH, or OL.
 - 2) In addition, any soil which cannot be compacted sufficiently to achieve the percentage of maximum density specified for the intended use shall be classified as unsuitable material.
 - 3) Detrimental amounts of organic matter shall be no more than 5 percent. Amount of organic matter shall be determined based on ASTM Test Method D2974.
 - 4) Materials containing rock or similar irreducible material with a maximum dimension greater than 6 inches.
 - 5) Materials containing foreign manmade objects, such as construction debris.
 - 6) Materials of such unstable nature as to be incapable of being compacted to specified density using ordinary methods at optimum moisture content.
 - 7) Materials that are too wet to be properly compacted and circumstances that prevent suitable in-place drying prior to incorporation into the new Flood Wall. However, the presence of excessive moisture in a material is not, by itself, sufficient cause for determining that the material is unsuitable – this shall be assessed by the Geotechnical Engineer during earthmoving activities.
 - 8) Materials that are unsuitable for the planned use as described in the Contract Documents and/or Contract Drawings.

2.2 USE OF FILL, BACKFILL, AND EMBANKMENT MATERIAL TYPES

- A. The Contractor shall use the types of materials as designated herein and as shown on the Contract Documents and/or Contract Drawings for all required construction.
- B. Fill, backfill, and embankment types shall be used in accordance with the following provisions:
 - 1. Earthwork not included below or specified elsewhere shall be constructed of Fill Material as defined herein and within the Contract Documents and/or Contract Drawings.
 - 2. Aggregate Base materials under pavements, sidewalk slabs, curb and gutters shall be constructed to the thicknesses shown or specified in the Contract Documents and/or Contract Drawings. Materials shall meet the requirements of NYC or NYS DOT.
 - 3. Backfill materials beneath the Flood Wall foundations shall be as shown in the Contract Documents and/or Contract Drawings.
 - 4. Trench backfill and final backfill for utilities under slabs shall be the same material as used within the pipe zone, except where concrete encasement is required by the Contract Documents and/or Contract Drawings.

PART 3 – EXECUTION

3.1 GENERAL

- A. Excavations shall be shored and braced as set forth in the rules, orders, and regulations of the City of New York and OSHA. The Contractor's shoring and bracing and general trenching operation shall consider vehicular and other loads that may be applied near the edge of an open trench and shall be in accordance with Section 31 50 00 - Excavation Support and Protection.
- B. Excavation shall include removal of all waters that interfere with the construction work. Dewatering shall be in accordance with Section 31 23 19 - Dewatering.
- C. Excavated spoils not used for backfill in approved areas shall be dumped directly into trucks for hauling off the site.
- D. Excavated spoils may be staged correctly with the appropriate slopes and at a height no higher than 6 feet at an authorized area within the site and covered/protected from the elements.

- E. Staged and protected excavated spoils shall not obstruct pedestrian and worker passage within Right-of-Ways (ROW).
- F. Dumping of excavated materials onto adjacent pavements will not be permitted.
- G. Excavation widths for the installation of the new Flood Wall foundations and associated appurtenances is shown on the Contract Drawings.
- H. Safe and convenient passage for pedestrians shall be provided during trench excavations. The Engineer may designate a passage to be provided at any point deemed necessary. Access to fire stations, fire hydrant, and hospitals shall be maintained at all times.

3.2 STRUCTURE, PAVEMENT AND UTILITY EXCAVATIONS

- A. The Contractor shall submit an excavation plan for review before any excavation commences.
- B. All excavations shall be protected and secured from pedestrian and vehicular traffic. This will entail the Contractor to provide appropriate fencing, concrete barricades, signage and other Maintenance and Protection of Traffic (MPT) controls.
- C. Excavations near areas of pedestrian or vehicular traffic shall be open the minimum time necessary to complete the work but shall not exceed 4 days maximum before backfilling the trench or excavation.
- D. Except when specifically provided to the contrary, excavation shall include the removal of all materials of whatever nature encountered, including all obstructions of any nature that would interfere with the proper execution and completion of the new Flood Wall.
- E. The removal of said materials shall conform to the lines and grades shown or ordered. Unless otherwise provided, the entire construction site shall be stripped of all vegetation and debris, and such material shall be removed from the site prior to performing any excavation or placing any fill.
- F. All excavations shall be supported in a safe manner in accordance with applicable State safety requirements and the requirements of OSHA as specified herein.
- G. All excavations shall be dewatered in accordance with Section 31 23 19 - Dewatering and shored in accordance with Section 31 50 00 - Excavation Support and Protection, if necessary.

- H. Excavations shall be carried to a grade of 12 inches below the bottom of the foundation footing or key.
- I. At all slabs on grade, the excavation shall be carried to a grade of 6 inches below the bottom of the slab.
- J. Ample workspace within the protected excavation shall be provided.
- K. Excavation under areas to be paved shall extend to the bottom of the Aggregate Base unless additional removal is required for removal of existing fill materials and unsatisfactory soils as outlined herein. After the required excavation has been completed, the exposed surface shall be scarified, brought to optimum moisture content and compacted.
- L. Unless otherwise shown, ordered, or accepted by the Engineer, excavation for utilities shall be vertical trenches, shored if required, and shall be uniform width from top to bottom.
- M. Existing utilities, manholes, drainage structures, and other facilities shall be protected, supported, and kept in service.
- N. The bottom of the trench shall be excavated uniformly. The trench bottom shall be given a final trim, using a laser to set the string line for establishing grade, such that each pipe section when first laid will be continually in contact with the ground along the extreme bottom of the pipe.
- O. Rounding out the trench to form a cradle for the pipe will not be required. Bell holes shall be excavated in the pipe bedding material as required to ensure uniform bearing of the pipe barrel on the bottom of the trench.
- P. If the maximum trench width is exceeded, the Contractor shall consult the Engineer immediately, and the Contractor shall provide additional bedding, another more stringent type of bedding, or higher strength pipe as directed by the Engineer at no additional cost to the BPCA or General Contractor.
- Q. The maximum lengths of open trench permitted in any one location shall be the length necessary to accommodate the amount of pipe installed in a single day or 100 ft, whichever is lesser. The distance is the collective length at any location, including open excavation, pipe laying and appurtenance construction, and backfill that has not been temporarily resurfaced.
- R. All trench excavations shall be fully backfilled at the end of each day, unless use of steel plates is permitted.

- S. Use of steel plates as open trench covers are permitted with approval by the Engineer and the BPCA or General Contractor and as described below:
 - 1. Trench plates will be allowed to cover a minimum area over the end of the last section of pipe installed each day, provided the trench is properly shored.
 - 2. Temporary backfill of the trench in the plated area is not required.
 - 3. When pedestrian or vehicular traffic plates are authorized, they shall be provided with non-skid coating and cold mix asphalt around the plate perimeter.

- T. Where steel plates cannot be used, trenches shall be backfilled with an approved fill material (such as Gravel or Aggregate Base) and topped with temporary paving.

3.3 OVEREXCAVATION AND REPLACEMENT

- A. Where actual conditions during Construction-Phase indicate that trenches shall be over-excavated and when directed by the Engineer, they shall be excavated to the depth as directed by the Engineer, and then backfilled/compacted to the grade of the bottom of the bedding.

- B. If the bottom of the excavation is found to consist of soft or unstable material which is incapable of properly supporting the pipe or structure, the Engineer shall be advised immediately. At the Engineer's direction, such material shall be removed to the depth and for the lengths specified and the trench installed with the appropriate geotextile to prevent migration of fines and backfilled to grade with Gravel or compacted Drain Rock.

- C. When over-excavation is ordered by the Engineer, compensation will be provided to the Contractor.
 - 1. The Contractor shall obtain the Engineer's written approval prior to over-excavating.
 - 2. Any over-excavating and resultant backfill and compaction without such approval shall be at the Contractor's expense. The quantity of approved unsuitable material excavated and its replacement shall be paid for as extra work, as directed by the Engineer.

3.4 DISPOSAL OF EXCESS EXCAVATED MATERIAL

- A. The Contractor shall remove and dispose of all excess excavated material in a legal manner at a site located off-site as selected by the Contractor and reviewed by the Engineer.

3.5 FOUNDATION SUBGRADE

- A. All native soils and existing fills at the subgrade level shall be cleaned of deleterious materials, visually inspected and probed by the Engineer to determine if satisfactory for foundation support.
- B. Where unsatisfactory soils and other deleterious material are encountered by the Contractor during excavation to the foundation subgrade elevations, removal and replacement shall be performed per the Overexcavation and Replacement Sections.
- C. The subgrade soils beneath rigid concrete pavements and foundations shall be proof-rolled using the appropriate compaction equipment with the effective number of overlapping passes as noted in the Contract Drawings and/or as directed by the Engineer.
- D. Prior to placing any concrete, subgrade soils shall be moisture conditioned between 2 and 5 percent above laboratory optimum moisture per ASTM D1557.

3.6 GENERAL BACKFILL OF MATERIALS

- A. Backfill shall not be dropped at a significant height directly upon any structure or pipe.
- B. Backfill shall not be placed around or upon any structure until the concrete has attained sufficient strength to withstand the loads imposed and has been in place for seven (7) days.
- C. Backfill around water retaining structures shall not be placed until structure has been tested, and structures shall be full of water when backfill is being placed.
- D. Except for materials being placed in over-excavated areas, backfill shall be placed after all water is removed from the excavation.
- E. Backfill materials shall be placed and spread evenly in layers, loose depth 8 inches or less as specified herein.
- F. During spreading of the backfill, each layer shall be thoroughly mixed as necessary to promote uniformity of material in each layer.
- G. Where the backfill material moisture content is too low to permit the specified degree of compaction, water shall be added before or during spreading until the proper moisture content is achieved. Jetting will not be permitted for compaction.

- H. Where the backfill material moisture content is too high to permit the specified degree of compaction, the material shall be dried until the moisture content is satisfactory.
- I. Storage of backfill materials overnight at the job site is prohibited, unless stored in a designated stockpile area.

3.7 FLOOD WALL BACKFILL MATERIALS

- A. Where at-grade foundation footprints transition from excavation backfill to the existing soil outside the excavation, existing soil shall be over-excavated to a minimum depth of three feet below the bottom of the foundation and backfilled with Aggregate Base and shall be in accordance with the requirements defined herein for removal of existing fill materials and weak soils and site preparation beneath all slab-on-grade and concrete foundations.
- B. In localized areas, where there is not adequate space to properly compact backfill, Sand shall be used as backfill. Flowable Fill may be used to mitigate voids and other inaccessible areas where backfill and compaction cannot be performed effectively.
- C. Fill material shall be spread and compacted in uniform horizontal lifts not exceeding 8 inches in loose thickness and to a minimum relative compaction as noted herein.
- D. Original pavements (asphalt or concrete), tree stumps, roots, topsoil, organic soils, construction debris, garbage and other deleterious material cannot be left in place and backfilled over – these materials shall be removed completely before backfilling.
- E. Flowable Fill shall be designed and placed using approved and accepted methods, at location where warranted by the Engineer (such as voids or around areas where backfill and compaction equipment is not possible).

3.8 UTILITY TRENCH BEDDING AND BACKFILL

- A. Pipe zone backfill materials shall be manually spread around the pipe so that when compacted, the pipe zone backfill will provide uniform bearing and side support.
- B. Sand or Coarse Bedding shall first be placed to a depth so that the pipe has support over its full length. Additional bedding material will be placed to a point no greater than $\frac{1}{4}$ of the pipe diameter. The bedding shall then be uniformly placed in maximum 6-inch thick loose lifts on each side of the pipe, thoroughly shovel-sliced into the haunch area of the pipe before the backfill is brought up to the spring line of the pipe. Above the spring line of the pipe, pipe zone backfill shall be brought up in 8-inch lifts to a point that is 12 inches over the top of the pipe; placed and compacted.

- C. The pipe zone shall be backfilled with the specified backfill material as specified in the Contract Documents and/or Contract Drawings. The Contractor shall exercise care to prevent damage to the pipeline coating, cathodic bonds if present and the pipe itself during the installation and backfill operations.
- D. Bell or coupling holes shall be provided. Do not shovel-slice bedding material into the bell or coupling hole.
- E. After the pipe zone backfill has been placed as specified above, and after all excess water has completely drained from the trench, backfilling of the trench zone may proceed.
- F. Trench zone backfill shall be placed in maximum 8-inch-thick loose lifts.
- G. Where pipe embedment is disturbed after compaction, such as by the removal of sheeting and shoring, the BPCA or General Contractor may require recompaction to the specified minimum limit.
- H. If the allowable deflection specified for the pipe is exceeded, the Contractor shall expose and re-round or replace the pipe, repair all damaged lining and coating, and reinstall the pipe zone material and trench backfill as specified at no additional expense to the BPCA or General Contractor.

3.9 COMPACTION OF ALL BACKFILL MATERIALS

- I. If Aggregate Base is used as backfill around the wall foundations, it shall be compacted in lifts no greater than 8 inches in thickness to at least 95 percent of maximum dry density (i.e., relative compaction) and at a soil moisture content at or near optimum soil moisture. The maximum dry density and optimum moisture content shall be determined by ASTM D1557 test methods.
- J. If Gravel is to be used as backfill around the wall foundations, minimal compaction by the appropriate equipment shall be used.
- K. Compaction equipment chosen by the Contractor shall not exert damaging forces on the adjacent structures/walls.
- L. Each layer of backfill materials as defined herein shall be mechanically compacted to the specified percentage of maximum density. Equipment that is consistently capable of achieving the required degree of compaction shall be used and each layer shall be compacted over its entire area while the material is at the required moisture content.

Lightweight tampers or vibrating plate compactors shall be used in utility trenches to prevent damage to existing or new utilities.

- M. All backfill shall be uniformly moisture-conditioned to between 2 and 6 percent above the optimum moisture content and placed in horizontal lifts less than 8 inches in loose thickness.
- N. Compaction of backfill adjacent to all subgrade structure walls shall follow a pattern of compaction that begins at the wall face and progresses outward to the outside edge of the excavation before beginning a new lift.
- O. Flooding, ponding, or jetting shall not be used as a means for compaction.
- P. All backfill materials placed below 3 feet above the top of the pipe should be compacted with hand-compaction equipment. Materials placed above 3 feet above the top of the pipe shall be compacted using heavier, self-propelled compaction equipment.
- Q. After hand-compacting the bedding, the Contractor shall perform a final trim using a string line for establishing grade, such that each pipe Section when first laid will be continually in contact with the bedding along the extreme bottom of the pipe.
- R. Additional QC tests may be made at the request of the Engineer to verify that compaction is meeting the specified requirements.
- S. If compaction fails to meet the specified requirements, the Contractor shall remove and replace the backfill at proper compaction or shall increase the compaction to specified level by other means acceptable to the Engineer. Subsequent tests required to verify that the reconstructed backfill meets the specified compaction shall be paid by the Contractor.
- T. Track rig, loader or dump truck walking of fill to achieve compaction shall not be allowed.
- U. The following compaction test requirements shall be in accordance with ASTM D1557, or in accordance with ASTM D4253 and D4254, as applicable:

Location of backfill	Required % Compaction
Asphaltic and concrete pavements	95
Beneath footings, foundation walls, slabs and pads	95

Location of backfill	Required % Compaction
Around footings and slabs	95
Beneath anchor blocks and around threaded anchor bar trenches	95
Behind existing and new Flood Wall	92
Behind foundation walls	90
Beneath landscaped areas and walkways	90
Behind new Flood Wall between STA 3+11.10 and STA 4+05.15	90
Above and around utility pipe zone	90

3.10 DISPOSAL OF SURPLUS MATERIAL

- A. Remove excess earth materials, unsuitable materials, and debris from the site and dispose of it in a legal manner. Location of disposal site and length of the haul shall be the Contractor's responsibility. Site shall be located off BPCA or General Contractor property.

3.11 EXISTING UTILITIES

- A. Locate and indicate on the Contract Drawings utilities and/or other facilities, which may conflict with, cross, or lie close to the new Flood Wall.
- B. While the existing utility locations shown in the Contract Drawings are believed to be reasonably correct, neither the Engineer nor the BPCA can guarantee the accuracy or adequacy of this information.
- C. The Contractor shall verify the location and depth (elevation) of all existing utilities and services prior to performing excavation work in an area. Contractor shall record on the record drawings the location and depth (elevation) of all existing utilities and services and any that are discovered during excavation.
- D. The Contractor shall call One Call or Call Before You Dig (811) at least 5 working days prior to start of any excavations and confer with all agencies and utilities that have or may have aboveground and/or underground facilities in the vicinity of the new Flood Wall and other associated utilities.
- E. The purpose of One Call is to notify said agencies and utilities of the proposed construction schedule and locate and/or verify the locations of all facilities, including connections, in the area of the new Flood Wall within the ROW.

- F. The Contractor shall arrange for all necessary suspension of service and make arrangements to physically locate and avoid interference with all existing utilities and facilities.
- G. The Contractor may make arrangements for alterations or relocations for his sole convenience (not actually required to complete foundation or utility installations); such alterations or relocations shall be completely at the expense of the Contractor.
- H. Where existing utilities and/or other facilities, aboveground and/or underground, are encountered during construction, they shall not be displaced or molested unless necessary.
- I. If it is necessary to relocate a utility or if a utility is disturbed or accidentally damaged in the construction of the new Flood Wall, the Contractor shall notify the BPCA, the General Contractor or the proper Authority.
- J. The Contractor shall abide with the requirements of and cooperate with BPCA or Authority (who may enter upon the new Flood Wall construction zone at any time) while protecting, repairing, replacing or relocating such utilities.
- K. All abandoned pipelines that are severed during the new Flood Wall construction shall be immediately plugged by the Contractor with approved material, unless otherwise directed by the Authority.
- L. A 12-inch minimum clearance shall be maintained at all utility crossings. Adjustments to the pipe alignment and elevation will be made by the Contractor where exploratory work indicates the need.
- M. Excavation around utilities shall follow the general protocol below:
 - 1. Excavation and other work under or adjacent to utilities shall not interfere with their safe operation and use.
 - 2. Contractor shall carefully probe to determine the exact location of utility, and hand excavate where necessary to avoid damages.
 - 3. In the event of damage incurred during construction, the Contractor shall immediately notify BPCA or the Authority and shall arrange for immediate repairs at his expense.

3.12 GEOTEXTILE FABRIC

- A. The fabric shall be provided in rolls wrapped with protective covering to protect the fabric from mud, dirt, dust, debris, ultraviolet radiation, and abrasion due to shipping and handling.

- B. The fabric shall be free of defects or flaws that significantly affect its physical properties as it is intended for this Contract.
- C. Each roll of fabric in the shipment shall be labeled with a number or symbol to identify that production run.
- D. Geotextile fabric shall be handled and installed in accordance with the manufacturer's recommendations and as noted in the Contract Drawings. The fabric shall be stretched, aligned, and placed in a wrinkle-free manner.
- E. Punctures in the geotextile shall be covered with a minimum 12-inch square patch.

3.13 SHORING REMOVAL

- A. Shoring shall be removed as soon as the trench backfill has been placed and compacted to a level adequate to support the trench walls, unless otherwise indicated.
- B. Compaction of the backfill shall be continuous throughout the shoring removal process in order to minimize the potential creation of voids between trench walls and compacted trench backfill.
- C. Observable voids created by removal of shoring shall be backfilled with the appropriate and approved fill material discussed herein and compacted as discussed herein.
- D. Shoring shall be completely removed prior to compaction of the top 4 feet of trench depth.

END OF SECTION 312000

SECTION 312319 - DEWATERING

PART 1 GENERAL

1.1 SECTION INCLUDES

- A. This section covers controlling groundwater, site drainage, and storm flows during construction. The Contractor is cautioned that the Work involves construction in and around drainage channels, local rivers, and areas of local drainage. These areas are subject to frequent periodic inundation.

1.2 RELATED SECTIONS

- A. The following is a list of Specifications which may be related to this section:
 - 1. Section 312000 - Earth Moving
 - 2. Section 311000 - Site Clearing
 - 3. Section 315000 - Excavation Support and Protection

1.3 REFERENCES

- A. The following is a list of standards which may be referenced in this section:
 - 1. New York City Department of Transportation (NYCDOT)
 - 2. New York City Department of Environmental Protection (NYCDEP)
 - 3. American Society for Testing and Materials International (ASTM):
 - a. D698, Standard Test Methods for Laboratory Compaction Characteristics of Soil Using Standard Effort (12 400 ft-lbf/ft³ or 600 kN-m/m³).

1.4 QUALITY ASSURANCE

- A. Installer Qualifications: Support of excavation and dewatering Contractor shall have, as a minimum, three (3) successful past installations and operations similar to those found on the Work.

1.5 SUBMITTALS

- A. Contractor shall submit a Water Control Plan to the Engineer two (2) weeks prior to execution of this Work. At a minimum, the Water Control Plan shall include:
 - 1. Descriptions of proposed groundwater and surface water control facilities including, but not limited to, equipment, methods, standby equipment and power supply, means of measuring inflow to excavations, pollution control facilities, regulatory permitting (NYCDEP), effluent testing, discharge locations to be utilized, and provisions for immediate temporary water supply as required by this Section.

2. Drawings showing locations, dimensions, and relationships of elements of each system.
3. Design calculations demonstrating adequacy of proposed dewatering systems and components.
4. If system is modified during installation or operation, revise or amend and resubmit Water Control Plan.

PART 2 PRODUCTS

2.1 MATERIALS

- A. Onsite materials may be used within the limits of construction to construct temporary dams and berms. Materials such as plastic sheeting, sand bags, and storm sewer pipe may also be used if desired by Contractor.

PART 3 EXECUTION

3.1 GENERAL

- A. For all excavation, Contractor shall provide suitable equipment and labor to remove water, and keep the excavation dewatered so that construction can be carried on under dewatered conditions.
 1. Water control shall be accomplished such that no damage is done to adjacent channel banks or structures.
 2. Continuously control water during course of construction, including weekends and holidays and during periods of work stoppages, and provide adequate backup systems to maintain control of water.
- B. Contractor is responsible for investigating and becoming familiar with all site conditions that may affect the Work including surface water, potential flooding conditions, level of groundwater and the time of year the work is to be done.
- C. Contractor shall conduct operations in such a manner that storm or other waters may proceed uninterrupted along their existing drainage courses.
 1. By submitting a bid, Contractor acknowledges that Contractor has investigated the risk arising from such waters and has prepared bid accordingly and assumes all of said risk.
- D. For all excavation, Contractor shall provide suitable equipment and labor to remove water, and keep the excavation dewatered so that construction can be carried on under dewatered conditions.
 1. Any damage to adjacent property resulting from Contractor's alteration of surface or subsurface drainage patterns shall be repaired by Contractor at no additional cost to Owner.
- E. Pumps and generators used for dewatering and water control shall be quiet equipment enclosed in sound deadening devices.

- F. Contractor shall remove all temporary water control facilities when they are no longer needed or at the completion of this Work.
- G. All excavations made as part of dewatering operations shall be backfilled with the same type material as was removed and compacted to ninety-five percent (95%) of Maximum Standard Proctor Density (ASTM D698) except where replacement by other materials and/or methods are required.

3.2 CONSTRUCTION

A. Surface Water Control:

- 1. Surface water control generally falls into the following categories:
 - a. Normal low flows along the channel.
 - b. Storm/flood flows along the channel.
 - c. Flows from existing storm drain pipelines.
 - d. Local surface inflows not conveyed by pipelines.
- 2. Contractor shall coordinate, evaluate, design, construct, and maintain temporary water conveyance systems:
 - a. These systems shall not worsen flooding, alter major flow paths, or worsen flow characteristics during construction. Contractor is responsible to ensure that any such worsening of flooding does not occur.
 - b. Contractor is solely responsible for determining the methods and adequacy of water control measures.
- 3. At a minimum, Contractor shall be responsible for diverting the quantity of surface flow around the construction area so that the excavations will remain free of surface water for the time it takes to install these materials, and the time required for curing of any concrete or grout.
- 4. Contractor is cautioned that the minimum quantity of water to be diverted is for erosion control and construction purposes and not for general protection of the construction site.
 - a. It shall be Contractor's responsibility to determine the quantity (volume and flow) of water which shall be diverted to protect from damage caused by stormwater, perched water and /or groundwater.
- 5. Contractor shall, at all times, maintain a flow path for all channels:
 - a. Temporary structures such as berms, sandbags, pipeline diversions, etc., may be permitted for the control of channel flow, as long as such measures are not a major obstruction to flood flows, do not worsen flooding, or alter historic flow routes.

B. Groundwater Control:

1. Contractor shall install adequate measures to maintain the level of groundwater below the foundation subgrade elevation and maintain sufficient bearing capacity for all structures, pipelines and earthwork.
 - a. Such measures may include, but are not limited to, installation of perimeter subdrains and swales, or by pumping from sumps installed below the subgrade elevation.
2. The structure bearing surfaces are to be kept dewatered and stable until the structures or other types of work are complete and backfilled.
 - a. Disturbance of foundation subgrade by Contractor operations shall not be considered as originally unsuitable foundation subgrade and shall be repaired at Contractor's expense.
3. Contractor shall dispose of groundwater as follows:
 - a. Containment: upon extraction, store groundwater extracted in the process of construction dewatering in containers prior to discharge or disposal of water, as applicable. Keep containers locked to prevent accidental or purposeful discharge of the water. Contain and store the water on-site and in such a manner that it will not interfere with the Contractor's existing or continued construction operations.
 - b. Obtain discharge permit for water disposal from authorities having jurisdiction.
 - c. Treat water collected by dewatering operations, as required by regulatory agencies, prior to discharge.
 - d. Discharge water as required by discharge permit and in manner that will not cause erosion or flooding, or otherwise damage existing facilities, completed Work, or adjacent property.
 - e. Remove solids from treatment facilities and perform other maintenance of treatment facilities as necessary to maintain their efficiency.
4. Any temporary dewatering trenches or well points shall be restored following dewatering operations to reduce permeability in those areas as approved by Engineer.
5. Extracted groundwater of sufficient quality as shown by test data may be used on site with Engineer's written approval for those purposes approved by the Engineer.

END OF SECTION 312319

SECTION 323120 - DECORATIVE METAL PANELS

PART 1 - GENERAL

1.1 RELATED DOCUMENTS

- A. Drawings and general provisions of the Contract, including General and Supplementary Conditions and Division 01 Specification Sections, apply to this Section.

1.2 SUMMARY

A. Section Includes:

- 1. Decorative aluminum panels.

B. Related Requirements:

- 1. Section 051000 - "Structural Steel" for Structural Steel Floodwall.
- 2. Section 099113 - "Exterior Painting" for structural steel priming and painting.

1.3 PREINSTALLATION MEETINGS

- A. Preinstallation Conference: Conduct conference at Project site.

1.4 ACTION SUBMITTALS

- A. Product Data: For each type of product.

- B. Shop Drawings: For decorative panels.

- 1. Include plans, elevations, sections, gate locations, post spacing, mounting and attachment details.

- C. Samples: For each fence material and for each color specified.

- 1. Provide Samples 12 inches in length for linear materials.
- 2. Provide Samples 36 inches square for decorative panel including decorative pattern for verification of pattern, finish and workmanship.

1.5 QUALITY ASSURANCE

- A. Installer Qualifications: Fabricator of products.

- B. Mockups: Build mockups to verify selections made under Sample submittals, to demonstrate aesthetic effects, and to set quality standards for fabrication and installation.

- 1. Include full-size single panel, including attachment hardware mounted to structural steel wall or concrete wall and complying with requirements.
- 2. Subject to compliance with requirements, approved mockups may become part of the completed Work if undisturbed at time of Substantial Completion.

PART 2 - PRODUCTS

2.1 PERFORMANCE REQUIREMENTS

- A. Wind Loading:
 - 1. Panel Height: 0 to 15 feet.
 - 2. Wind Exposure Category: C.
 - 3. Design Wind Speed: 98 mph.

2.2 DECORATIVE ALUMINUM PANELS

- A. Decorative Aluminum Panels: Panels made from aluminum plate.
- B. Decorative Panels: Aluminum plate, type 6061, 1/4 inch thick.
- C. Decorative pattern: 'Stix' by ANOVA Furnishings. Panels to have 1.5" solid continuous border with pattern inset.
 - 1. Pattern to be designed for largest panel and centered, then trimmed from the sides or bottom as necessary to accommodate smaller panels. No stretching of the pattern.
 - 2. No openings that pass a 4" sphere authorized.
- D. Fasteners: Stainless steel, tamperproof, with neoprene washers and sleeves to prevent galvanic action.
- E. Fabrication: Custom panel patterns may be produced by laser-cutting, water jet or CNC.
 - 1. Edges shall be smooth without sharp edges, burs or creases.
- F. Finish exposed welds to comply with NOMMA Guideline 1, Finish #2 - completely sanded joint, some undercutting and pinholes okay.

2.3 ALUMINUM

- A. Aluminum, General: Provide alloys and tempers with not less than the strength and durability properties of alloy and temper designated in paragraphs below for each aluminum form required.
- B. Plate and Sheet: ASTM B 209, Alloy 6061-T6.'

2.4 STEEL AND IRON

- A. Plates, Shapes, and Bars: ASTM A 36/A 36M.

2.5 COATING MATERIALS

- A. Epoxy Zinc-Rich Primer for Uncoated Steel: See Section 099113 "Exterior Painting".
- B. Anti-Graffiti Coating for Decorative Panels: Clear protective coating that provides a barrier between the applied to surface and graffiti.

1. Product: Anti-Graffiti Coat as manufactured by Coval Molecular Coatings, Burleson, TX (817) 233-6926.

2.6 MISCELLANEOUS MATERIALS

- A. Welding Rods and Bare Electrodes: Select according to AWS specifications for metal alloy welded.
 1. For aluminum, provide type and alloy as recommended by producer of metal to be welded and as required for strength and compatibility in fabricated items.
- B. Neoprene-backed washers and sleeves.
 1. For separating dissimilar metals to prevent galvanic actions. See Drawings.
 - a. Stainless steel neoprene-backed washers.
 - b. Neoprene sleeves.
- C. Surface Cleaner for Anti-Graffiti Coating system: Surface cleaner applied prior to application of anti-graffiti coating.
 1. Product: Step #1 Cleaner for Painted Surfaces as manufactured by Coval Molecular Coatings, Burleson, TX (817) 233-6926.

2.7 ALUMINUM FINISHES

- A. Class 1 clear architectural anodization- A41 per AAMA 611-98.

2.8 STEEL FINISHES

- A. Surface Preparation: Clean surfaces according to SSPC-SP 6/NACE No. 3, "Commercial Blast Cleaning." After cleaning, apply a conversion coating compatible with the organic coating to be applied over it.
- B. Shop-Painted Finish: Comply with Section 099113 "Exterior Painting."

PART 3 - EXECUTION

3.1 EXAMINATION

- A. Examine areas and conditions, with Installer present, for compliance with requirements for site clearing, earthwork, pavement work, construction layout, and other conditions affecting performance of the Work.
- B. Do not begin installation before final grading is completed unless otherwise permitted by Architect.
- C. Proceed with installation only after unsatisfactory conditions have been corrected.

3.2 PREPARATION

- A. Mark locations of panel lines and corresponding bracket mounting hardware locations.
 - 1. Construction layout and field engineering are specified in Section 017300 "Execution."

3.3 DECORATIVE PANEL INSTALLATION

- A. Install panels by mounting as indicated and fastening infill panels to floodwall panels as shown on the Drawings.

END OF SECTION 323119

SECTION 329113 - SOIL PREPARATION

PART 1 - GENERAL

1.1 RELATED DOCUMENTS

- A. Drawings and general provisions of the Contract, including General and Supplementary Conditions and Division 01 Specification Sections, apply to this Section.

1.2 SUMMARY

- A. Section includes planting soils including layered soil assemblies specified by composition of the mixes AND the reinstallation of the existing soils to be salvaged and amended prior to reinstallation.
- B. Related Requirements:
 - 1. Section 311000 "Site Clearing"
 - 2. Section 329300 "Plants"

1.3 UNIT PRICES

- A. Work of this Section is affected by unit prices specified in Division 01 - "Alternates & Unit Prices".

1.4 DEFINITIONS

- A. Backfill: The earth used to replace or the act of replacing earth in an excavation.
- B. Compaction: Compaction of the soil fabric is any force applied to the soil that reduces porosity and where 90 percent of all compaction can be accomplished with only three application of force under optimum soil moisture conditions.
- C. Dry Soil: The condition of the soil at or below the wilting point of plant available water in which the soil is subject to blowing.
- D. Finish Grade: Elevation of finished surface of planting soil.
- E. Frozen Soil: The point at which the soil water has frozen and the soil has become very hard and cloddy. Ice crystals can be seen in the pore spaces of the soil.
- F. Manufactured Topsoil: Soil produced off-site by homogeneously blending mineral soils or sand with stabilized organic soil amendments to produce topsoil or planting soil.
- G. Moist Soil: the condition of the soil in where it can be formed into a ball and maintain its shape. Deformation of the soil is difficult with hand pressure. Free water is not visible and is usually considered the point between the wilting point and filed capacity of the soil.

- H. Pests: Living organisms that occur where they are not desired, or that cause damage to plants, animals, or people. These include insects, mites, grubs, mollusks (snails and slugs), rodents (gophers, moles, and mice), unwanted plants (weeds), fungi, bacteria, and viruses.
- I. Planting Area: Areas to be planted.
- J. Planting Soil: Standardized topsoil; existing, native surface topsoil; existing, in-place surface soil; imported topsoil; or manufactured topsoil that is modified with soil amendments and perhaps fertilizers to produce a soil mixture best for plant growth.
- K. Plant; Plants; Plant Material: These terms refer to vegetation in general, including trees, shrubs, vines, ground covers, ornamental grasses, bulbs, corms, tubers, or herbaceous vegetation.
- L. Saturated: All the pore space within a soil is filled with water and the remaining water is under gravitational forces to drain through the profile.
- M. Scarification: The loosening of the surface of a soil lifts by mechanical or manual means to alleviate compaction of the soil surface. Depth of scarification is dependent on material and extent of compaction.
- N. Subgrade: Surface or elevation of subsoil remaining after excavation is complete, or the top surface of a fill or backfill before planting soil is placed.
- O. Subsoil: All soil beneath the topsoil layer of the soil profile, and typified by the lack of organic matter and soil organisms.
- P. Surface Soil: Soil that is present at the top layer of the existing soil profile at the Project site. In undisturbed areas, the surface soil is typically topsoil; but in disturbed areas such as urban environments, the surface soil can be subsoil.
- Q. Wet Soils: Soil that is considered wet will easily be deformed by hand pressure, maintain their shape and free water will be visible within the pore spaces. The water content at this soil condition is considered field capacity or wetter.

1.5 CRITICAL PATH BLENDING

- A. The Contractor shall submit required soil submittal and their associated specified test results six months prior to the scheduled soil and plant installation.
- B. The Soil Blending contractor shall be engaged at least six months prior to schedule soil installation to allow for sufficient time for material searches and initial planting blend approvals.

1.6 PREINSTALLATION MEETINGS

- A. Preinstallation Conference: The contractor shall examine previous work, related work and conditions under which this work is to be performed and shall notify the Landscape Architects in writing of all deficiencies and conditions detrimental to the proper completion of this work. Beginning work means the contractor accepts substrates, pervious work and conditions. The Contractor shall not place any planting soil until all work in adjacent areas is complete and approved by the Landscape Architect.

1.7 ACTION SUBMITTALS

- A. Product Data: Submit technical descriptive data for each manufactured or packaged product of this Section. Include manufacturer's product testing and analysis and installation instructions for manufactured or processed items and materials.
- B. Locations: Submit locations of material sources. Submit location of mixing sites.
1. Soil Mix supplier shall have a minimum of five years experience in supplying custom planting soil mixes.
 2. Submit supplier name, address, telephone and fax numbers and contract name.
 3. Submit certification that accepted supplier is able to provide sufficient quantities of materials and mixes for the entire project.
 4. Landscape Architect shall have the right to reject any soil supplier.
- C. Test Reports – Soil Analysis: The Contractor shall submit representative samples of all soil materials and organic material components which are intended to be used for planting soil mixes and final mixes, to a Soil and Plant Testing Laboratory acceptable to the Battery Park City Parks Conservancy. All reports shall be sent to the Landscape Architect for approval. Samples of all soil materials to be brought to the site must be approved before delivery. Deficiencies in the soils shall be corrected organically (peatmoss is not acceptable) by the Contractor, as directed by the Landscape Architect after review of the testing agency report. Testing reports shall include the following:
1. Date issued.
 2. Project Title and names of Contractor and material supplier.
 3. Testing laboratory name, address and telephone number, and name(s), as applicable, of each field and laboratory inspector.
 4. Date, place, and time of sampling or test, with record of temperature and weather conditions.
 5. Location of material source.
 6. Type(s) of test.
 7. Results of tests including identification of deviations from acceptable ranges.
 8. Particle size analysis to include sand sieve analysis shall be performed and compared to the USDA Soil Classification System per ASTM D422 (hydrometer test) or ASTM F1632 (pipette test). The silt and clay content shall be determined on soil passing the #270 sieve and shall be reported separately.
 9. Percent of organic shall be determined by an Ash Burn Test or Walkley/Black Test, ASTM F1647.
 10. Saturated hydraulic conductivity per any of the test methods stated in ASTM F1815.
 11. Chemical analysis shall be undertaken for Nitrate, Ammonium, Nitrite, Phosphorous, Potassium, Calcium, Magnesium, Iron, Manganese, Zinc, Copper, Soluble Salts, Cation Exchange Capacity, and acidity (pH).
 12. Soil analysis tests shall show recommendations for soil additives, including organic and inorganic soil amendments, necessary to accomplish particular planting objectives noted.

13. All tests shall be performed in accordance with the current standards of the Association of Official Agriculture Chemists.
 14. Certified reports on analysis from producers of composted organic materials are required, particularly when sources are changed. The analysis performed shall include pH, density, salinity, total organic nitrogen, C:N Ratio, Solvita Maturity Index, moisture, sodium, potassium, calcium, magnesium, and phosphorous.
 15. Soil Components and Soil Mix Sampling requirements: At middle height of wind row/pile, remove sample two feet into the pile. Place sample in clean container. Repeat gathering methods for five to ten times at equidistant spacing on both sides of the pile. Mix gathered samples with clean utensils. Remove approximately 500g of composite samples and place that final sample by overnight courier to the testing laboratory. Submit sample with completed testing laboratory submission form.
 16. Biological Tests for organisms in compost and mixes:
 - a. Contact the testing laboratory to review testing and sampling requirements before sending samples.
 - b. Sampling requirements: At middle height of wind row, remove sample two feet into the pile. Place sample in clean container. Repeat gathering methods for five to ten times at equidistant spacing on both sides of the compost pile. Mix gathered samples with clean utensils. Remove approximately 500g of composite samples and place that final sample by overnight courier to the testing laboratory. Submit sample with completed testing laboratory submission form.
 - c. Maintain clear and concise records for testing and sampling procedures.
 17. Testing Agencies: The following firms are acceptable testing agencies for the various components.
 - a. Compost testing:
 - 1) Woods End Research Laboratory, PO Box 297, Mt. Vernon, ME 04352, phone 800-451-0337, fax 207-293-2488.
 - b. Physical soil analysis including particle size analysis and hydraulic conductivity
 - 1) Hummel & Company Inc., 35 King Street Trumansburg, NY 14886 Phone 607-387-5694
 - c. Soil chemical analysis:
 - 1) University of Massachusetts West Experiment Station, Amherst, MA 01003, phone 413-545-2311, fax 413-545-1931.
 - d. Compost/Biological Testing:
 - 1) Soil Foodweb New York, 17 Clinton Street, Center Moriches, NY 11934, tel. 631-750-1553, fax 631-750-1554.
- D. All approved samples to be submitted to Landscape Architect:
1. Leaf mold, each source, 5 lb. packaged.

2. Sand, each source, 5 lb. packaged.
 3. Loam, each source, 5 lb. packaged.
 4. Base component material, each source, 5 lb. packaged.
 5. Yard Waste Compost, each source, 5 lb. packaged.
 6. Each mix type specified 5 lb. packaged.
- E. Statement(s) of Qualifications: Submit within 45 days of notice to proceed to confirm qualifications as specified herein.
- F. Equipment Data: Submit descriptive information with wheel load data for each proposed item of equipment to be used for execution of earthwork of this Contract. Equipment Data will be evaluated for conformance to site restriction of use.
- G. Schedule and Protection Plan: Submit a detailed plan for scheduling and sequencing of all contract work and for protection of soil mixes and other completed work including coordination with contractors requiring access through the site. Indicate with schedules and plans the utilization of finished work protection measures (wooden protection boards or other approved methods) over the work area of construction operations concurrent with all construction operations until substantial completion.
- H. Schedule for performing percolation tests.

1.8 QUALITY ASSURANCE

- A. Testing Agency Qualifications: An independent, state-operated, or university-operated laboratory; experienced in soil science, soil testing, and plant nutrition; with the experience and capability to conduct the testing indicated; and that specializes in types of tests to be performed.

1.9 TESTING REQUIREMENTS

- A. General: Perform all tests on components and soil blends according to requirements in this article.

1.10 DELIVERY, STORAGE, AND HANDLING

- A. Packaged Materials: Deliver packaged materials in original, unopened containers showing weight, certified analysis, name and address of manufacturer, and compliance with state and Federal laws if applicable.
- B. Bulk Materials:
1. Do not dump or store bulk materials near structures, utilities, walkways and pavements, or on existing turf areas or plants.
 2. Provide erosion-control measures to prevent erosion or displacement of bulk materials, discharge of soil-bearing water runoff, and airborne dust reaching adjacent properties, water conveyance systems, or walkways.
 3. Do not blend soil mixes, move or handle materials when they are wet or frozen.
 4. Accompany each delivery of bulk fertilizers and soil amendments with appropriate certificates.

PART 2 - PRODUCTS

2.1 MATERIALS

A. Jute Netting: Erosion Control fabric blanket, made from 100% natural jute fibers. Blanket weave has spaces of approximately 1/4" x 1/4".

1. "U" shaped steel staples for anchors. 6"

B. General- Salvaged Planting Soils

1. Existing Planting Soils shall be removed, labeled and maintained off site during construction. Prior to reinstallation, and as early as weather permits, soils shall be tested for organic content and quantitative biological testing for 5-7% organic content. If these soils do not meet that criterion they shall be amended with the specified organic matter resulting in a 5-7% organic content. In addition, they shall be tested for quantitative biological as specified herein.

C. General – Newly Blended Soils

1. Newly blended soil quantities to be determined by quantities calculated during removal with appropriate "fluff" factor.
2. All soil mix material shall fulfill the requirements for new soil mixes as specified.
3. Samples of individual components of soil mixes and also blended soil mixes shall be submitted by the Contractor for testing and analysis to the approved testing laboratory. Include verification testing of on-site sub soils. Comply with specific materials requirements specified.
 - a. No base component or soil components for soil mixes shall be used until certified test reports by an approved agricultural chemist have been received and approved by the Landscape Architect.
 - b. As necessary, make any and all soil mix amendments and resubmit tests reports indicating amendments until approved.
4. The Landscape Architect, Construction Manager or BPCA/BPCPC may request additional testing by Contractor for confirmation of mix quality and/or soil mix amendments at any time until completion.
5. Base Component Material shall be sand that meets the requirements outlined below mixed by volume with loam material that meets the requirements outlined below. Base component materials shall not be site salvaged and must be off-site borrow material.
6. Test sand and loam components individually as components and together to form the Base Component mixed materials, for compliance with material specifications. These test criteria and results, when approved, shall establish the standard to which all subsequent Base Component Material tests must conform.
7. Organic matter (leaf mold or yard waste compost) shall be tested prior to mixing Base Component Material with organic matter. Have one (1) composite organic

matter sample tested from each 50 c.y. of material intended for use in soil mixes of planting work.

8. Testing requirements for components and mixes:

- a. Organic matter as a component
- b. Sand as a component
- c. Loam as a component
- d. Sand + Loam for Base Component
- e. Base Component + Organic for various Soil Mixes

D. Organic Matter: Organic matter for amending planting media shall be a stable, material produced from the aerobic decomposition and curing of leaf/yard wastes. The compost shall meet the following criteria

- 1. Organic matter content of no less than 40% as determined by ASTM 2974
- 2. Moisture content of 35 to 70% as determined by ASTM D2974.
- 3. Carbon to nitrogen ratio of 15:1 to 30:1
- 4. Soluble salts not exceeding 4 dSm⁻¹
- 5. Solvita Maturity Index 6 to 8
- 6. 95 – 100% passing a 3/8” screen
- 7. pH 6 to 7.5
- 8. Biological Organisms: The compost shall have the following levels of organisms (direct microscopy).
 - 15 to 25 or more µg active bacteria /g dry weight (dw) compost
 - 100 µg (fungal compost) to 300 or more µg (bacterial compost) total bacteria /g dw compost
 - 15 to 25 µg or more active fungi /g dw compost
 - 100 to 300 µg total fungal biomass /g dw compost
 - 10,000 or more flagellates
 - 10,000 or more amoebae
 - 50 - 100 ciliates.
 - 20 – 30 Total nematodes (No root feeding nematodes)
- 9. Nutrient cycling capacity will be a minimum of 200 lbs/available nitrogen per acre due to microbial presence and activity.

E. Sand for Base Component Material shall meet the following requirements:

1. Texture:

<u>Sand Fraction</u>	<u>Size (mm)</u>	<u>Sieve Size</u>	<u>% Passing</u>
Gravel	> 2.0	#10	95 – 100%
Very coarse sand	1.0 – 2.0	#18	90 – 100%
Coarse sand	0.5 – 1.0	#35	65 – 75%
Medium sand	0.25 – 0.5	#60	15 – 20%
Fine sand	0.1 – 0.25	#140	0 – 4%
Very fine sand	0.05 – 0.1	#270	0 – 2%

2. Chemical Analysis:

- 1) Soil reaction (pH) - $5.0 - 6.5 \pm 0.5$
- 2) Soluble salt content (Conductivity) - $< 1.5 \text{ dSm}^{-1}$

3. Material shall have a saturated hydraulic conductivity rate of no less than 30 inches per hour, per ASTM 1815.

F. Loam for Base Component Material shall meet the following requirements:

- a. Soil Texture per ASTM D422 or ASTM F1632, as determined on material passing a 2 mm screen:

<u>Main Fractions</u>	<u>Size (mm)</u>	<u>Percent</u>
Sand	0.05-2.0	83 - 87
Silt	0.002-0.05	7 - 10
Clay	<0.002	4 - 8

In addition, maximum size shall be $\frac{1}{2}$ ", the total gravel ($> 2 \text{ mm}$) shall be less than 10% of the total material, and the sand passing the 2 mm screen shall have the following particle size distribution:

<u>Sand Fraction</u>	<u>Size (mm)</u>	<u>Sieve Size</u>	<u>% Passing</u>
Very coarse	1.0 - 2.0	#18	87-90
Coarse	0.5 - 1.0	#35	65-71
Medium	0.25 - 0.5	#60	34-42
Fine	0.10 - 0.25	#140	17-23
Very fine	0.05 - 0.10	#270	14-18

b. Chemical Analysis:

- 1) Organic matter content (%) oven dry weight of soil shall be within the range of 4 to 10%.
- 2) Soil reaction (pH) - 6.0 ± 0.5
- 3) Soluble salt content (Conductivity) - $< 1.5 \text{ dSm}^{-1}$

1. Before base sand-loam mix (base component) is used for mixing with organic amendments, handle and pile the mix in the following manner:

- a. Mix the base sand with base loam in a ratio of 3 parts sand to 1 part loam. Adjustments to the ratio may have to be made to meet the specifications for the base component. Homogenize to make a uniform mix, free of subsoil lenses and other irregularities.
- b. Aerate the base component to make a friable planting medium.
- c. Screen out all clay lumps, stones, roots, and other debris.

2. Material Requirements, Base Component Mix: The final mix of sand and loam materials shall substantially conform to the following:

- a. Soil Texture per ASTM D422 or ASTM F1632, as determined on material passing a 2 mm screen:

<u>Main Fractions</u>	<u>Size (mm)</u>	<u>Percent</u>
Sand	0.05-2.0	95.0
Silt	0.002-0.05	3.0
Clay	<0.002	<u>2.0</u>

In addition, maximum size shall be ½", the total gravel (> 2 mm) shall be less than 5% of the total material, and the sand passing the 2 mm screen shall have the following particle size distribution:

<u>Sand Fraction</u>	<u>Size (mm)</u>	<u>Sieve Size</u>	<u>% Passing</u>
Very coarse sand	1.00	#18	92-95
Coarse sand	0.50	#35	67-73
Medium sand	0.25	#60	20-26
Fine sand	0.10	#140	5-9
Very fine sand	0.05	#270	5

b. Nutrient Analysis:

1. Ammonium (NH₄) and Nitrate (NO₃): below 100 ppm
2. Phosphorous
3. Potassium
4. Calcium (CA), Magnesium (Mg): ratio of 7 part Ca to 1 part Mg
5. Iron (Fe) 1 to 4 ppm
6. Manganese (Mn) 3 to 20 ppm
7. Zinc (Zn) 0.1 to 70 ppm
8. Copper (Cu) 0.3 to 8 ppm

Chemical Analysis:

1. Organic matter content (%) oven dry weight of soil: 1- 4%
2. Soil reaction (pH): 6 - 7
3. Soluble salt content (Conductivity) - < 1.5 dSm⁻¹

- c. Saturated hydraulic conductivity of no less than 15 inches per hour per ASTM F1815.

2.2 PLANTING SOILS MIXES

- A. Adequate quantities of mixed planting soil materials shall be provided to attain, after compaction and natural settlement, all design finish grades.
- B. Uniformly mix ingredients using a mechanical soil blender designed for such purpose as specified for each Mix Type (Base Component Material, compost, and other ingredients deemed to be necessary as a result of testing). Wind rowing/tilling on an approved hard surface area may also be used as an alternative. Organic matter shall be maintained moist, not wet during mixing.
 1. Mixing of Amendments: Add organic amendment in proportions as specified and as confirmed by testing. Other amendments shall not be added unless approved to extent and quantity by Battery Park City Parks Conservancy and additional tests have been conducted to verify type and quantity of amendment is acceptable.

C. Testing of Plant Mixes:

1. Perform initial tests to confirm compliance with base material and mix specifications. These test results, when approved, will establish the standard to which all other test results must conform.
2. Follow-up Testing: Have one (1) composite sample delivery and upon arrival to the site from each 500 c.y. or as required by the Landscape Architect for use in each type plant mix to include the following:
 - a. Particle size analysis: Use sieve sizes as specified for Base Component Material.
 - b. Organic matter content as per mix specified.
 - c. Nutrient Analysis:
 - 1) Have nutrient levels (pH, ammonium nitrogen, nitrate nitrogen, nitrite nitrogen, phosphorus, potassium, magnesium, calcium, magnesium, zinc, iron, copper, and manganese) tested, and request testing laboratory recommendations for additional fertilizer requirements at all plant areas if nutrient levels are below average. Soluble salts shall also be tested.
 - 2) Contractor shall not use amendments to correct nutrient deficiencies.
 - d. Biological Organisms: The mixes shall have a minimum of the following levels of organisms (direct microscopy). Refer to Article 1.08 C for testing and sampling requirements. Natural nutrient cycling will be a minimum of 150 lbs per acre, available Nitrogen from microbial activity. Mix shall have microbiological populations as listed below. Acceptance or rejection of mixes based on these test values will be determined by the Landscape Architect.

Plant Material	Active Bacterial Biomass (ug/g)	Total Bacterial Biomass (ug/g)	Active Fungal Biomass (ug/g)	Total Fungal Biomass (ug/g)	Hyphal Diameter (ug/g)	Protozoa Numbers/g			Total Beneficial Nematode Numbers (#/g)
						Flagellates Ciliates	Amoebae		
Deciduous Trees and Shrubs	40-60	400-800	30-45	400-900	3.0	10,000	10,000	50-100	20-30

- D. Soil Mix Types: Provide the following planting soil mix types at the locations indicated on plan. Percentages of components, unless otherwise noted, will be established upon completion of individual test results for components of the various mixes. The controlling factor will be the percent (%) organic matter as specified for each mix. Note that percent (%) by volume of components will be, in large part, determined by the compost. Specifically the bulk density of the compost will directly impact the organic matter readings that have been specified for each mix.

1. Raised Beds-Upper Root Zone:

- a. Organic Component shall be mixed with the Base Component (sand-loam) mix at a rate necessary to provide an organic matter content of 4.8-6% by weight, as determined by ASTM F1647. pH shall be 6.5 to 7.0. Cation Exchange Capacity shall be between 10 and 15. Natural nutrient cycling will be a minimum of 150 lbs per acre, available Nitrogen from microbial activity.
2. Raised Beds-Lower Root Zone:
- a. Organic Component shall be mixed with the Base Component (sand-loam) mix at a rate necessary to provide an organic matter content of 5.0-6% by weight, as determined by ASTM F1647. pH shall be 6.5 to 7.0. Cation Exchange Capacity shall be between 10 and 15. Natural nutrient cycling will be a minimum of 150 lbs per acre, available Nitrogen from microbial activity.
3. Furrow- Root Zone:
- a. Organic Component shall be mixed with the Base Component (sand-loam) mix at a rate necessary to provide an organic matter content of 6.0-6.5% by weight, as determined by ASTM F1647. pH shall be 6.5 to 7.0. Cation Exchange Capacity shall be between 10 and 15. Natural nutrient cycling will be a minimum of 150 lbs per acre, available Nitrogen from microbial activity.

4. Raised Beds & Furrow-Drainage Zones:

a. Texture:

<u>Sand Fraction</u>	<u>Size (mm)</u>	<u>Sieve Size</u>	<u>% Passing</u>
Gravel	> 2.0	#10	93 – 100%
Very coarse sand	1.0 – 2.0	#18	85 – 90%
Coarse sand	0.5 – 1.0	#35	45 – 60%
Medium sand	0.25 – 0.5	#60	12 – 15%
Fine sand	0.1 – 0.25	#140	0 – 6%
Very fine sand	0.05 – 0.1	#270	0 – 5%

b. Chemical Analysis:

- 1. Soil reaction (pH) – 6.0- 6.5 ± 0.5
- 2. Soluble salt content (Conductivity) - < 1.5 dSm⁻¹

- c. Material shall have a saturated hydraulic conductivity rate of no less than 30 inches per hour, per ASTM 1815.

2.3 SOIL AMENDMENTS

- A. Ground Limestone: Ground Limestone as a soil amendment material will only be used pending results of analysis.
 - 1. Provide a Ground Agricultural Limestone with a minimum of 88% of calcium and magnesium carbonates
 - 2. Ground Limestone material shall have a total 100% passing the 10 mesh sieve, minimum of 90% passing the 20 mesh sieve and a minimum of 60% passing the 100 mesh sieve.

PART 3 - EXECUTION

3.1 - GENERAL

- A. Place planting soil and fertilizers according to requirements in other Specification Sections.
- B. Verify that no foreign or deleterious material or liquid such as paint, paint washout, concrete slurry, concrete layers or chunks, cement, plaster, oils, gasoline, diesel fuel, paint thinner, turpentine, tar, roofing compound, or acid has been deposited in planting soil. If contamination by foreign or deleterious material or liquid is present in soil, remove the soil and contamination as directed by Landscape Architect and replace with new planting soil to the extent directed by the Landscape Architect or BPCPC.
- C. Proceed with placement only after unsatisfactory conditions have been corrected.

3.2 PLACING MANUFACTURED PLANTING SOIL OVER EXPOSED SUBGRADE

- A. General: When placing either the Salvaged Planting Soils or the Newly Blended Soils DO NOT apply materials or till if existing soil or subgrade is frozen, muddy, or excessively wet
- B. Salvaged Planting Soils: Prior to placing Salvaged Planting Soils test for organic matter and quantitative biological as stated here in. The top 8" of Salvaged Planting Soils shall be amended as per these test results and placed after scarifying the installed Salvaged Planting Soils
- C. Newly Blended Soils: Apply manufactured soil on-site in its final, blended condition.
- D. Application: Place planting soil layers in the depths and as shown on the drawings to total depth not less than required to meet finish grades after natural settlement. Do not handle, spread soil or subgrade if frozen, muddy, or excessively wet.
 - 1. Lifts: Apply planting soil in lifts not exceeding 6 inches.
- E. Compaction for Planters: Compact each lift of planting soil to 85 percent of maximum Standard Proctor density according to ASTM D 698.
- F. Finish Grading for Planters: Grade planting soil to a smooth, uniform surface plane with loose, uniformly fine texture. Roll and rake, remove ridges, and fill depressions to meet finish grades. Landscape Architect to approve final grades prior to planting.

3.3 FIELD QUALITY CONTROL

- A. Testing Agency: Owner will engage a qualified testing agency to perform tests and inspections.
- B. Perform the following tests and inspections:
 - 1. Compaction: Test planting-soil compaction after placing each soil profile using a densitometer or soil-compaction meter calibrated to a reference test value based on laboratory testing according to ASTM D 698. Space tests at no less than one for each planter and three total at the street tree pits of in-place soil or part thereof.

2. Insitu Verification Testing: Contractor shall provide biological, pH, organic and soil texture test reports from labs used for approval of mixes for every 500 square feet of planter and 3 tests for the street tree pits.
- C. Soil will be considered defective if it does not pass tests.
 - D. Label each sample and test report with the date, location keyed to a site plan or other location system, visible conditions when and where sample was taken, and sampling depth.

3.4 PROTECTION

- A. Protection Zone: Protection Zones for the installation of salvaged soils and the specified blended soils of this specification are indicated on the drawings.
- B. Protect areas of in-place soil from additional compaction, disturbance, and contamination. Prohibit the following practices within these areas except as required to perform planting operations:

- Storage of construction materials, debris, or excavated material.
- Parking vehicles or equipment.
- Vehicle traffic.
- Foot traffic.
- Erection of sheds or structures.
- Impoundment of water.
- Excavation or other digging unless otherwise indicated.

- C. If planting soil or subgrade is over compacted, disturbed, or contaminated by foreign or deleterious materials or liquids, remove the planting soil and contamination; restore the subgrade as directed by Landscape Architect and replace contaminated planting soil with new planting soil.

3.5 CLEANING

- D. Protect areas adjacent to planting-soil preparation and placement areas from contamination. Keep adjacent paving and construction clean and work area in an orderly condition.
 - E. Remove surplus soil and waste material including excess subsoil, unsuitable materials, trash, and debris and legally dispose of them off Owner's property unless otherwise indicated.
- c. Dispose of excess subsoil and unsuitable materials on-site where directed by Owner.

END OF SECTION 329113

THIS PAGE INTENTIONALLY LEFT BLANK

SECTION 329300 - PLANTS

PART 1 - GENERAL

1.1 RELATED DOCUMENTS

- A. Drawings and general provisions of the Contract, including General and Supplementary Conditions and Division 01 Specification Sections, apply to this Section.

1.2 SUMMARY

A. Section Includes:

1. Trees
2. Shrubs
3. Goundcovers, Perennial, Herbaceous Plants and Vines
4. Mulch, fertilizer and other soil amendment applications to suit plant type during and after planting.
5. Protecting completed work.
6. Warranty
7. Coordination with other trades
8. Clean up

B. Related Requirements:

1. Section 311000 Site Clearing – for salvaged planting soil to be reused
2. Section 329113 Soil Preparation

1.3 UNIT PRICES

- A. Work of this Section is affected by unit prices specified in Division 01- Alternates & Unit Prices."
- B. Unit prices apply to authorized work covered by quantity allowances.
- C. Unit prices apply to additions to and deletions from the Work as authorized by Change Orders.

1.4 REFERENCES

- A. ANLA: American Nursery and Landscape Association (Formerly: AAN-American Association of Nurserymen)
- B. ANSI: American National Standards Institute
- C. AOAC: Association of Official Agricultural Chemists
- D. ASTM: American Society for Testing Materials.

1.5 APPLICABLE STANDARDS

- A. The references listed herein shall be in the standards used for performance of the Work: All standards shall include the latest additions and amendments as of the date of advertisement for bids.
1. American National Standards for Tree Care Operations, ANSI A300. American National Standards Institute, 11 West 42nd Street New York, NY 10036.
 2. American Standard for Nursery Stock, ANSI Z60.1 American Nursery and Landscape Associating, 1250 Eye Street NW Suite 500 Washington DC 20005
 3. Horticultural Standards, American Nursery & Landscape Association.
 4. Hortus Third, The Staff of the L.H.Bailey Hortorium. 1976. MacMillan Publishing Co, New York
 5. Standardized Plant Names, American Joint Committee on Horticultural Nomenclature, 1942 edition
 6. American Society for Testing Material (ASTM)
 7. International Society of Arboriculture.

1.6 DEFINITIONS

- A. Backfill: The earth used to replace or the act of replacing earth in an excavation.
- B. Balled and Burlapped Stock: Plants dug with firm, natural balls of earth in which they were grown, with a ball size not less than diameter and depth recommended by ANSI Z60.1 for type and size of plant required; wrapped with burlap, tied, rigidly supported, and drum laced with twine with the root flare visible at the surface of the ball as recommended by ANSI Z60.1.
- C. Container-Grown Stock: Healthy, vigorous, well-rooted plants grown in a container, with a well-established root system reaching sides of container and maintaining a firm ball when removed from container. Container shall be rigid enough to hold ball shape and protect root mass during shipping and be sized according to ANSI Z60.1 for type and size of plant required.
- D. Finish Grade: Elevation of finished surface of planting soil.
- E. Pesticide: A substance or mixture intended for preventing, destroying, repelling, or mitigating a pest. Pesticides include insecticides, miticides, herbicides, fungicides, rodenticides, and molluscicides. They also include substances or mixtures intended for use as a plant regulator, defoliant, or desiccant. Some sources classify herbicides separately from pesticides.
- F. Pests: Living organisms that occur where they are not desired or that cause damage to plants, animals, or people. Pests include insects, mites, grubs, mollusks (snails and slugs), rodents (gophers, moles, and mice), unwanted plants (weeds), fungi, bacteria, and viruses.
- G. Planting Area: Areas to be planted.
- H. Planting Soil for Soil Profiles: Soil produced off-site by homogeneously blending mineral soils or sand with stabilized organic soil amendments to produce topsoil or planting soil.
- I. Plant; Plants; Plant Material: These terms refer to vegetation in general, including trees, shrubs, vines, ground covers, ornamental grasses, bulbs, corms, tubers, or herbaceous vegetation.

- J. Subgrade: The surface or elevation of subsoil remaining after excavation is complete, or the top surface of a fill or backfill before planting soil is placed.

1.7 PREINSTALLATION MEETINGS

- A. Preinstallation Conference: Conduct conference at Project site to comply with requirements of Division 1.

1.8 ACTION SUBMITTALS

- A. Submittals shall conform to Section 013300-Shop Drawings, Product Data and Samples

- B. Product Data: For each type of product.

- 1. Plant Materials: Include quantities, sizes, quality, and sources for plant materials.
- 2. Plant Photographs: Include color photographs in **digital** format of each required species and size of plant material as it will be furnished to Project. These photos shall be submitted a minimum of 10 workdays prior to the tagging trip they are to be tagged. Take photographs from an angle depicting true size and condition of the typical plant to be furnished. Include a scale rod or other measuring device in each photograph. For species where more than 15 plants are required, include a minimum of three photographs showing the average plant, the best quality plant, and the worst quality plant to be furnished. Identify each photograph with the full scientific name of the plant, plant size, and name of the growing nursery.

- C. Samples for Verification: For each of the following:

- 1. Shrubs: Landscape Architect and BPCPC will accompany landscape contractor for tagging all plant material.
- 2. Milled Leaf Mulch: 1-quart (1-L) volume in sealed plastic bags labeled with composition of materials by percentage of weight and source of mulch. Each Sample shall be typical of the lot of material to be furnished; provide an accurate representation of color, texture, and organic makeup.

1.9 INFORMATIONAL SUBMITTALS

- A. Qualification Data: For landscape Installer. Include list of similar projects completed by Installer demonstrating Installer's capabilities and experience. Include project names, addresses, and year completed, and include names and addresses of owners' contact persons.

- B. Product Certificates: For each type of manufactured product, from manufacturer, and complying with the following. Submit inspection certificates required by authorities having jurisdiction. Supply Certificates of Compliance for all materials required for fabrication and installation, certifying that each material item complies with, or exceeds, specified requirements

- 1. Manufacturer's certified analysis of standard products including but not limited to:
 - a. Soil amendments
 - b. Mulch, maturity certification

2. Analysis of other materials by a recognized laboratory made according to methods established by the Association of Official Analytical Chemists, where applicable.
 - C. Pesticides and Herbicides: Product label and manufacturer's application instructions specific to Project.
 - D. Sample Warranty: For special warranty.
- 1.10 CLOSEOUT SUBMITTALS
- A. Maintenance Data: Recommended procedures to be established by Owner for maintenance of plants during a calendar year. Submit before expiration of required maintenance periods.
- 1.11 QUALITY ASSURANCE
- A. Installer Qualifications: A qualified landscape installer whose work has resulted in successful establishment of plants. Submit resumes for Landscape Project Manager, Foreman/Site Supervisor showing the following:
 1. Professional Membership: Installer shall be a member in good standing of either the Professional Landcare Network or the American Nursery and Landscape Association.
 2. Experience: Five years' experience in landscape installation.
 3. Installer's Field Supervision: Require Installer to maintain an experienced English speaking, full-time supervisor on Project site when work is in progress.
 4. Pesticide Applicator: State licensed, commercial.
 - B. Provide quality, size, genus, species, and variety of plants indicated. Provide only healthy, vigorous stock, grown in a recognized nursery acceptable to the Landscape Architect and BPCPC and free from disease, insects, eggs, larvae and other defects. Provide plants in strict compliance with the recommendations of the following:
 1. ANSI Z 60.1 American Standard for Nursery Stock, latest edition.
 2. American Association of Nurserymen, Horticultural standards.
 3. American Joint Committee on Horticultural Nomenclature, Standardized Plant Names, 1942 edition.
 4. International Society of Arboriculture.
 5. Selection of plants purchased under allowances is made by Landscape Architect, who tags plants at their place of growth before they are prepared for transplanting.
 6. Landscape Architect, Battery Park City Parks Conservancy staff member or Resident Engineer retains right to reject any plant at any time due to transportation damage, disease, loose rootball or lack of correct maintenance practices while plants are being maintained on site.
 - C. Measurements: Measure according to ANSI Z60.1. Do not prune to obtain required sizes.
 1. Shrubs: Measure with branches or canes in their normal position. Take height measurements from or near the top of the root flare for field-grown stock and container-grown stock. Measure main body of tree or shrub for height and spread; do not measure branches or roots tip to tip..

- D. Pruning: Unless otherwise noted, pruning of plants before, during or after installation shall be prohibited except to remove dead or broken branches and limbs. Confer with Landscape Architect before any pruning. Plants pruned without permission from the Landscape Architect are subject to rejection and replacement.
- E. Inspection: The Landscape Architect will inspect plant materials at place of growth before planting for compliance with requirement for genus, species, variety, size and quality. Landscape Architect retains right to inspect plant materials further for size and condition of balls and root systems, insects, injuries, and latent defect and to reject unsatisfactory or defective material at any time during progress of work even if previously inspected and approved. Remove and replace rejected plants immediately from Project site at no change to the Owner.
 - 1. Selection: All plants shall be tagged in the nursery by the Landscape Architect prior to digging of plants. The Landscape Architect shall place seals on selected plant at the nursery. Seals shall remain on plants until acceptance of work.

1.12 DELIVERY, STORAGE, AND HANDLING

- A. Packaged Materials: Deliver packaged materials in original, unopened containers showing weight, certified analysis, name and address of manufacturer, and indication of compliance with state and Federal laws if applicable.
- B. Bulk Materials:
 - 1. Do not dump or store bulk materials near structures, utilities, walkways and pavements, or on existing turf areas or plants.
 - 2. Provide erosion-control measures to prevent erosion or displacement of bulk materials; discharge of soil-bearing water runoff; and airborne dust reaching adjacent properties, water conveyance systems, or walkways.
 - 3. Accompany each delivery of bulk materials with appropriate certificates.
- C. Do not prune shrubs before delivery. Protect bark, branches, and root systems from sun scald, drying, wind burn, sweating, whipping, and other handling and tying damage. Do not bend or bind-tie trees or shrubs in such a manner as to destroy their natural shape. Provide protective covering of plants during shipping and delivery. Do not drop plants during delivery and handling.
- D. Handle planting stock by supporting the rootball or container
- E. Store bulbs, corms, and tubers in a dry place at 60 to 65 deg F until planting.
- F. Apply anti-desiccant to trees and shrubs using power spray to provide an adequate film over trunks (before wrapping), branches, stems, twigs, and foliage to protect during digging, handling, and transportation.
 - 1. If deciduous shrubs are moved in full leaf, spray with anti-desiccant at nursery before moving and again two weeks after planting.
- G. Deliver plants after preparations for planting have been completed and install immediately. If planting is delayed more than six hours after delivery, set plants and trees in their appropriate

aspect (sun, filtered sun, or shade), protect from weather and mechanical damage, and keep roots moist. Plants shall not be stored on asphalt or any other pavement without a minimum of 3-inches mulch layer over pavement.

1. Set balled stock on ground and cover ball with soil, mulch, sawdust, or other acceptable material.
2. Do not remove container-grown stock from containers before time of planting.
3. Water root systems of plants stored on-site deeply and thoroughly with a fine-mist spray. Water as often as necessary to maintain root systems in a moist, but not overly wet condition.

1.13 FIELD CONDITIONS

- A. Field Measurements: Verify actual grade elevations, service and utility locations, irrigation system components, and dimensions of plantings and construction contiguous with new plantings by field measurements before proceeding with planting work.
- B. Digging Season: Plants shall be delivered freshly dug. Plants dug the previous season shall not be accepted. When it is anticipated that planting will occur outside of the digging seasons, storage shall conform to the requirements of this Specification.
 1. Spring Dig: Plants shall be dug as early as determined by nursery owner and no later than bud break.
- C. Planting Restrictions: Plant during one of the following periods. Coordinate planting periods with maintenance periods to provide required maintenance from date of Substantial Completion.

Trees and Shrubs

	Spring Season	Fall Season
Perennials and Grasses	April 30 to June 15	Sept. 15 to Nov 1
Deciduous (container)	March 15 to June 15	Sept. 15 to Nov 1
Deciduous (Balled and burlapped)	March 15 to June 15	Sept. 15 to Nov 1

- D. Weather Limitations: Proceed with planting only when existing and forecasted weather conditions permit planting to be performed when beneficial and optimum results may be obtained. Apply products during favorable weather conditions according to manufacturer's written instructions and warranty requirements.

1.14 WARRANTY

- A. Special Warranty: Installer agrees to repair or replace plantings and accessories that fail in materials, workmanship, or growth within specified warranty period. Provide written warranty agreeing to remove and replace work that exhibits defect in materials or workmanship for the specified periods. "Defects" is defined to include, but is not limited to death, unsatisfactory growth, disease, insect infestation, abnormal foliage density, abnormal size abnormal color failure to thrive and other unsatisfactory characteristics.
 1. Failures include, but are not limited to, the following:
 - a. Death and unsatisfactory growth, except for defects resulting from abuse, lack of adequate maintenance, or neglect by Owner.

- b. Structural failures including plantings falling or blowing over.
 - c. Faulty performance of tree stabilization and tree grates
2. Warranty Periods: From date of Substantial Completion.
 - a. Trees: 12 months.
 - b. Shrubs: 12 months.
 - c. Ground Covers, Perennials, Ornamental Grasses and Other Plants: 12 months.
3. Include the following remedial actions as a minimum:
 - a. Immediately remove dead plants and replace unless required to plant in the succeeding planting season.
 - b. Replace plants that are more than 25 percent dead or in an unhealthy condition at end of warranty period.
 - c. A limit of one replacement of each plant is required except for losses or replacements due to failure to comply with requirements.

PART 2 - PRODUCTS

2.1 PLANT MATERIAL-GENERAL

- A. General: Furnish nursery-grown plants true to genus, species, variety, cultivar, stem form, shearing, and other features indicated in Planting Schedule indicated on Drawings and complying with ANSI Z60.1; and with healthy root systems developed by transplanting or root pruning. Provide well-shaped, fully branched, healthy, vigorous stock, densely foliated when in leaf and free of disease, pests, eggs, larvae, and defects such as knots, sun scald, injuries, abrasions, and disfigurement.
 1. Collected Stock: Do not use plants harvested from the wild, from native stands, from an established landscape planting, or not grown in a nursery unless otherwise indicated.
- B. Provide plants of sizes, grades, and ball or container sizes complying with ANSI Z60.1 for types and form of plants required. Plants of a larger size may be used if acceptable to Landscape Architect, with a proportionate increase in size of roots or balls.
- C. Hardiness: Provide plant stock certified to have been grown within hardiness Zones 2 through 6 as established by the Arnold Arboretum, Jamaica Plain Massachusetts. Plants without this certification will be rejected.
- D. Root-Ball Depth: Furnish shrubs with root balls measured from top of root ball, which begins at root flare according to ANSI Z60.1. Root flare shall be visible before planting.
- E. Root-Ball Handling: All plants balled and burlapped shall be moved with the root systems as solid units with balls of earth firmly wrapped with untreated biodegradable eight-ounce burlap. Firmly held in place by stout cord and drum lacing. The diameter and depth of the rootballs of earth must be sufficient to encompass the fibrous and root feeding system necessary for the healthy development of the plant. NO plant shall be accepted with the ball of earth surrounding its roots has been badly cracked or broken preparatory to or during the process of planting or after the burlap, stave, ropes or platform required connection with its transplanting have been

removed. The plants and balls shall remain intact during all operations. Burlap for containing rootballs shall be untreated, made from biodegradable natural fibers. Inspect root crown for girdling roots. Plants with girdling roots will be rejected.

1. Root flare of all plants shall be clearly visible prior to planting. Carefully avoid damage to roots while removing soil overburden from the rootball. Adventitious roots shall be removed with sharp pruners.

a. Root flares more than 2" below grade at source shall be cause for rejection. The Landscape Architect may request a larger diameter rootball to compensate for a buried root flare, as the soil overburden shall be removed prior to planting which effectively reduces the size of the root ball. This will be at no additional cost to the Owner.

F. Container Stock: Container stock shall have a full container of well-developed root system. Plants loose in the container are not acceptable. The surface of the root zone shall be free of circling or kinked roots. When removed from the container, the rootball shall be free from numerous circling roots. Large matted roots at the side or bottom of the container will not be accepted. Container grown plants may be accepted for balled and burlapped material if approved by Landscape Architect.

G. Labeling: Label each plant of each variety, and size, with a securely attached, waterproof tag bearing legible designation of common name and full scientific name, including genus and species. Include nomenclature for hybrid, variety, or cultivar, if applicable for the plant.

H. Select stock for uniform height and spread, and number the labels to assure symmetry in planting.

I. Handling of Plants: Plants delivered by truck and plants requiring overnight storage on site shall be properly wrapped and covered to prevent wind-drying and desiccation of branches, leaves and buds; plant balls shall be firmly bound, unbroken, reasonably moist to indicate watering prior to delivery and during storage, and tree trunks shall be free from fresh scare and damage in handling.

2.2 MULCH

A. Milled Leaf Mulch: Provide partially decomposed, minimum six-month-aged, finely shredded leaf mulch that is free of weeds, excessive fine particles and stringy material. Provide leaf mulch approved by Landscape Architect.

2.3 MISCELLANEOUS PRODUCTS

A. Anti-desiccant: Water-insoluble emulsion, permeable moisture retarder, film forming, for trees and shrubs. Deliver in original, sealed, and fully labeled containers and mix according to manufacturer's written instructions.

B. Burlap: Untreated biodegradable eight-ounce burlap.

- C. Mycorrhizal Fungi: Dry, granular inoculant containing at least 5300 spores per lb of vesicular-arbuscular mycorrhizal fungi and 95 million spores per lb of ectomycorrhizal fungi, 33-percent hydrogel, and a maximum of 5.5 percent inert material.

PART 3 - EXECUTION

3.1 EXAMINATION

- A. Examine areas to receive plants, with Installer present, for compliance with requirements and conditions affecting installation and performance of the Work.
 - 1. Verify that no foreign or deleterious material or liquid such as paint, paint washout, concrete slurry, concrete layers or chunks, cement, plaster, oils, gasoline, diesel fuel, paint thinner, turpentine, tar, roofing compound, or acid has been deposited in soil within a planting area.
 - 2. Verify that plants and vehicles loaded with plants can travel to planting locations with adequate overhead clearance and covered completely to be protected from the wind.
 - 3. Suspend planting operations during periods of excessive soil moisture until the moisture content reaches acceptable levels to attain the required results.
 - 4. Uniformly moisten excessively dry soil that is not workable or which is dusty.
- B. If contamination by foreign or deleterious material or liquid is present in soil within a planting area, remove the soil and contamination as directed by Landscape Architect and replace with new planting soil to the extend directed by the Landscape Architect or BPCPC.
- C. Proceed with installation only after unsatisfactory conditions have been corrected.

3.2 PREPARATION

- A. Protect structures, utilities, sidewalks, pavements, and other facilities and turf areas and existing plants from damage caused by planting operations.
- B. Install erosion-control measures to prevent erosion or displacement of soils and discharge of soil-bearing water runoff or airborne dust to adjacent properties and walkways.
- C. Preinstallation Examination Required: The contractor shall examine previous work, related work and conditions under which this work is to be performed and notify Landscape Architect in writing of all deficiencies and conditions detrimental to the proper completion of this work. Beginning work means contractor accepts substrates, previous work and conditions. The contractor shall not place any plants or planting soil mixtures until all work in adjacent areas is complete and accepted by the Landscape Architect.
- D. Planting Soil Mixture Preparation: Refer to Section 311000 Site Clearing for salvaged and maintaining Planting Soil Section 329113 and Soil Preparation-for Planting Soil to makeup volumes lost during storage
- E. General: Prepare planting area for soil placement and mix planting soil according to Section 329113 Soil Preparation.
- F. Placing Planting Soil: according to Section 329113 Soil Preparation.

- G. Lay out individual shrub locations and areas for multiple plantings. Stake locations, outline areas, adjust locations when requested, and obtain Landscape Architect's acceptance of layout before excavating or planting. Make minor adjustments as required.
- H. Mark herbaceous groupings as shown on Planting Plans for approval of Landscape Architect and BPCPC. Final layout of all herbaceous plants will be as per the design Landscape Architect and BPCPC. Contractor shall understand groupings on the Planting Plans may change as per field conditions. No additional cost to the Owner will be allowed for these adjustments.
- I. Application of Mycorrhizal Fungi: At time directed by Landscape Architect, broadcast dry product uniformly over prepared soil at application rate as indicated by biological test results performed as per Section 329113 Soil Preparation.

3.3 PLANTING

- A. Roots: Do not plant if roots are girdling. Landscape Architect, BPCPC or Resident Engineer retains the right to reject all plants with this condition.
- B. Balled and Burlapped Stock: Set each plant plumb and in center of planting pit or trench with root flare 1 inch above adjacent finish grades.
 - 1. Remove all burlap prior to backfilling pits.
 - 2. Backfill: Planting soil as per drawings.
 - 3. After placing some backfill around root ball to stabilize plant, carefully cut and remove burlap and rope from tops of root balls and from sides, but do not remove from under root balls. Remove pallets, if any, before setting. Do not use planting stock if root ball is cracked or broken before or during planting operation.
 - 4. Backfill around root ball in layers, tamping to settle soil and eliminate voids and air pockets. When planting pit is approximately one-half filled, water thoroughly before placing remainder of backfill. Repeat watering until no more water is absorbed.
 - 5. Continue backfilling process. Water again after placing and tamping final layer of soil.
- C. Container-Grown Stock: Set each plant plumb and in center of planting pit or trench with root flare 1-inch above adjacent finish grades.
 - 1. Backfill: Planting soil
 - 2. Carefully remove root ball from container without damaging root ball or plant.
 - 3. Backfill around root ball in layers, tamping to settle soil and eliminate voids and air pockets. When planting pit is approximately one-half filled, water thoroughly before placing remainder of backfill. Repeat watering until no more water is absorbed.
- D. Planting Bulbs: Plant bulbs concurrently with ground cover if season of planting permits. The design Landscape Architect and BPCPC shall approve layout of bulbs. Plant bulbs to proper depth for species, place shoots upright. Provide 1 teaspoon of Bonemeal per bulb mixed in the planting hole.

3.4 PLANTING TREES AND SHRUBS

- A. Planting Bed Preparation for Shrubs: Create continuous plant bed in planters; do not place plants in pits. Plant soil mixture will be used to back fill the planters

1. Plant Installation: All Planting Soil salvaged and marked for relocation to original location shall be placed in depths needed to meet proposed grades. Prior to planting, salvaged soils shall be tested for organic content and quantitative biology as per Section 329113 Soil Preparation.
 2. Any newly blended soils required in addition to the salvaged soils shall be placed as per Section 329113 Soil Preparation.
 3. Inspection: At time of planting, verify that root flare is visible at top of root ball according to ANSI Z60.1. If root flare is not visible, remove soil in a level manner from the root ball to where the top-most root emerges from the trunk. After soil removal to expose the root flare, verify that root ball still meets size requirements.
 4. Staking and Layout: Stake trees and obtain Landscape Architect's acceptance of location and finish grade elevation before planting.
 5. Ball Pedestals: Provide a rootball pedestal immediately beneath the ball or root mass so that tree or plant will not settle and will have the relationship to finish grade described below.
 6. Obstructions: If obstruction or other conditions detrimental to healthy plant growth are encountered, notify Landscape Architect immediately and request additional instruction. At the Landscape Architect's direction and at no additional cost to Owner, plants shall be relocated to avoid the obstruction.
 7. Keep excavations covered or otherwise protected when unattended by Installer's personnel.
- B. Backfill Soil: Subsoil and topsoil removed from excavations may not be used as backfill soil unless otherwise indicated.
- C. Obstructions: Notify Landscape Architect if unexpected rock or obstructions detrimental to trees or shrubs are encountered in excavations.
1. Hardpan Layer: Drill 6-inch diameter holes, 24 inches apart, into free-draining strata or to a depth of 10 feet, whichever is less, and backfill with free-draining material.
- D. Drainage: Notify Landscape Architect if subsoil conditions evidence unexpected water seepage or retention in tree or shrub planting pits.
- E. Fill excavations with water and allow to percolate away before positioning trees and shrubs.
- 3.5 SHRUB AND VINE PRUNING
- A. Remove only dead, dying, or broken branches according to standard professional horticultural and arboricultural practices Do not prune for shape.
 - B. Do not apply pruning paint to wounds.
- 3.6 GROUND COVER AND PLANT PLANTING
- A. Set out and space ground cover and plants other than trees, shrubs, and vines as indicated on Drawings in even rows with triangular spacing.
 - B. Use planting soil as indicated on drawings for backfill.
 - C. Dig holes large enough to allow spreading of roots.

- D. For rooted cutting plants supplied in flats, plant each in a manner that minimally disturbs the root system but to a depth not less than two nodes.
- E. Work soil around roots to eliminate air pockets and leave a slight saucer indentation around plants to hold water.
- F. Water thoroughly after planting, taking care not to cover plant crowns with wet soil.
- G. Protect plants from hot sun and wind; remove protection if plants show evidence of recovery from transplanting shock.

3.7 PLANTING AREA MULCHING

- A. Mulch backfilled surfaces of planting areas and other areas indicated.
 - 1. Organic Mulch in Planting Areas: Apply 2-inch average thickness of organic mulch over whole surface of planting area, and finish level with adjacent finish grades. Do not place mulch within 6 inches of trunks or stems.

3.8 PLANT MAINTENANCE

- A. Maintain plantings by pruning, cultivating, watering, weeding, fertilizing, mulching, restoring planting saucers, adjusting and repairing tree-stabilization devices, resetting to proper grades or vertical position, and performing other operations as required to establish healthy, viable plantings. Of particular importance is weeding and mulching. Contractor to review project for weeding needs weekly through the maintenance period.
- B. Fill in, as necessary, soil subsidence that may occur because of settling or other processes. Replace mulch materials damaged or lost in areas of subsidence.
- C. Apply treatments as required to keep plant materials, planted areas, and soils free of pests and pathogens or disease. Use integrated pest management practices when possible to minimize use of pesticides and reduce hazards. Treatments include physical controls such as hosing off foliage, mechanical controls such as traps, and biological control agents.

3.9 PESTICIDE APPLICATION

- A. Apply biological control agents according to authorities having jurisdiction and manufacturer's written recommendations. Coordinate applications with BPCPC'S operations and others in proximity to the Work. Notify BPCPC before each application is performed.
- B. Pre-Emergent Herbicides (Selective and Nonselective): Apply to tree, shrub, and ground-cover areas according to manufacturer's written recommendations. Do not apply to seeded areas. Apply only with the knowledge and direction of BPCPC.
- C. Post-Emergent Herbicides (Selective and Nonselective): Apply only as necessary to treat already-germinated weeds and according to manufacturer's written recommendations. Apply only with the knowledge and direction of BPCPC.

3.10 REPAIR AND REPLACEMENT

- A. General: Repair or replace plants that are damaged by construction operations, in a manner approved by Landscape Architect and BPCPC.
 - 1. Protect all soils to remain during all waterproofing and pavement installations.
 - 2. Submit details and products to be used during all construction operations and those of proposed repairs or remediation.
 - 3. Perform repairs within 24 hours, if approved.
 - 4. Replace trees and other plants that cannot be repaired and restored to full-growth status, as determined by Landscape Architect.
- B. Remove and replace plants that are more than **25** percent dead or in an unhealthy condition immediately or are damaged during construction operations that Landscape Architect determines are incapable of restoring to normal growth pattern.
 - 1. Provide any replacements at same size and form.
 - 2. Species of Replacement Trees: Same species being replaced

3.11 CLEANING AND PROTECTION

- A. During planting, keep adjacent paving and construction clean and work area in an orderly condition. Clean wheels of vehicles before leaving site to avoid tracking soil onto roads, walks, or other paved areas.
- B. Remove surplus soil and waste material including excess subsoil, unsuitable soil, trash, and debris and legally dispose of them off Owner's property.
- C. Protect plants from damage due to landscape operations and operations of other contractors and trades. Maintain protection during installation and maintenance periods. Treat, repair, or replace damaged plantings.
- D. After installation and at the direction of the Landscape Architect remove nursery tags, nursery stakes, tie tape, and other debris from plant material, planting areas, and Project site.
- E. At time of Substantial Completion, verify that watering devices are in good working order and leave them in place. Replace improperly functioning devices.

3.12 MAINTENANCE SERVICE

- A. Maintenance: Provide maintenance by skilled employees of landscape installer. Begin maintenance immediately after plants are installed and continue until plantings are acceptably healthy and well established, but for not less than maintenance period below:
 - 1. Maintenance Period: 12 months after Substantial Completion

END OF SECTION 329300

THIS PAGE INTENTIONALLY LEFT BLANK

EXHIBIT I

(Acknowledgement of Addenda)

RFP TITLE: _____

Complete Part I or Part II, whichever is applicable, and sign your name in Part III.

Part I

Listed below are the dates of issue for each Addendum received in connection with this RFP:

Addendum # 1, Dated _____, ____

Addendum # 2, Dated _____, ____

Addendum # 3, Dated _____, ____

Addendum # 4, Dated _____, ____

Addendum # 5, Dated _____, ____

Addendum # 6, Dated _____, ____

Part II Acknowledgement of No Receipt

_____ No Addendum was received in connection with this RFP

Part III

Proposer's Name: _____

Proposer's Authorized Representative:

Name: _____

Title: _____

Signature: _____

Date: _____

EXHIBIT J

List of BPCA & BPCPC Board Members and Employees

LIST OF BOARD MEMBERS

George J. Tsunis

Donald Capoccia

Lester Petracca

Louis J. Bevilacqua

Catherine McVay Hughes

Martha J. Gallo

Anthony Kendall

Employees:

Betzayda Abreu
Deborah Addison
Curtis Afzal
Elsa Alvarez
Dana Anders
Anthony Andriano
Stephen Arciold
Sharmila Baichu
Marie Baptiste
Brett Beecham
Freddy Belliard
Marieke Bender
Marcus Billups
Emily Birdseye
Nidia Blake-Reeder
LaToya Brooks-Jones
Nancy Buivid
Anthony Buquicchio
Peter Campbell
Frances Caperchi
Monica Centeno
Julissa Cooke
Sarah Fisher-Curtin
Gwen Dawson
Nicole Dawson
Gilbert DePadua
Paul Diaz-Larui
Tonasia Dopson
Jennifer Dudgeon
Abigail Ehrlich
Maria Ellison
Richard Faraino
Anitra Fauntleroy
Claudia Filomena
Tamara Flores
Pamela Frederick
James Gallagher
Abigail Goldenberg
Anastasia Gonzalez
Lenron Goode
Neresa Gordon
Sakina Graves
Ned Greenberg
Evelyn Gregg
Jonathan Gross
Robert Hansen
Nicole Heater

Sankar Heerah
Robert Hinkelman
Craig Hudon
Jake Jacevicius
Amy Jogie
William John
Jasmine Johnson
Benjamin Jones
Roland Kemp
Ann Ketring
Susie Kim
Karl Koenig
Leandro Lafuente
Michael LaMancusa
Della Lee
Rene Lopcy
Janira Lopez
Robert Maggi
Evelin Maisonet
Jonathan McCain
Princess McNeill
Justin McLaughlin-Williams
Brian Meikle
Vanessa Mesine
Ronnie Mohammed
Dana Morgera
Eric Munson
Lauren Murtha
Bertha Narcisse
Jahmeliah Nathan
Robert Nesmith
Siu May Ng
Yoshihiro Nishida
Anne O'Neill
Maril Ortiz
Bienvenido Osorio
Kevin O'Toole
Hector Oyola
Willem Paillant
Jonathan Parker
Nimisha Haribaran Patel
Gladys Pearlman
Dahlia Pena
Bruno Pomponio
Katherine Powell
Sandra Power

Robert Quon
Jason Rachnowitz
Madelin Ramirez
Aline Reynolds
Chad Rimer
Manual Rivera
Anthony Robinson
Kim Robledo
Nelson Rogers
Jose Rosado
Holly Ross
Carlos Santiago
Nicholas Sbordone
Jean Schwartz
Iphigenia Seong
Rekha Sewraj
Sean Simon
Kemnarine Singh
Sarah Smedley
Bruce Spierer
Shinay Stewart
Jerome Sturiano
Lance Super
John Tam
Alexis Torres
Ryan Torres
Douglas Van Horn
Noe Velasquez
Evangelio Villalobos
Jeffrey Vixamar
Sharon Wade
David Wallace
Annalise Warren
Eric White
Dwight Williams
Kenneth Windman
Al Wright
Erin Yokoi
Nishida Yoshihiro
Alaura Zayas